

INJ. PUMP CALIBRATION DATA

ENGINE MODEL 4BD1

BOSCH No. 9 400 610 008
 DKKC No. 101401-0270
 Date: 20.Nov.1986 ⑤
 Company: ISUZU
 No. 5-15601-215-2

Injection pump : PES4A Governor : EP/RLD Timing device : EP/SCD
 101040-8340 105931-0511 105622-0730

1. Test Conditions :

Pump rotation : clockwiseviewed from drive side
 Nozzle & Nozzle Holder Ass'y : 105780-0000 Nozzle Holder : 105780-2080
 (BOSCH Type No.DN12SD12) (BOSCH Type No.EF8511/9A)
 Nozzle opening pressure : 175 Kg/cm² Transfer pump pressure : 1.6 Kg/cm²
 Injection pipe : Inner Dia. 2 mm X Outer Dia. 6 mm - Length 600 mm
 Test Oil : ISO4113 or SAE Standard Test Oil (SAE J967d) Oil Temp. : 40⁺⁵ °C
 Overflow valve opening pressure : 1.6 Kg/cm²

2. Injection Timing :

Pre-stroke : No. 1 Plunger 3.6 ±0.05mm
 Note : Adjust with control rod position of mm
 Injection order : 1 ~ 3 ~ 4 ~ 2 (interval : 90 °±30')

Plungers are numbered from the Drive side.

Tappet clearance : Bolt adjustment type ; More than 0.3mm for all cylinders.
 Shim adjustment type ; Manually rotate the camshaft 2~3 times and confirm that it rotates smoothly.

4. Injection Quantity :

Adjusting Point	Rod Position (mm)	Pump Speed (r.p.m)	Injection Q'ty (cc/1000 strokes)	Max. var bet. cyl (%)	Fixed	Remarks
A	11.4	950	69.0 ~ 72.0	±2.5	Rack	Basic
H	9.5	290	6.7 ~ 9.3	±14	Rack	
A	11.4	950	69.5 ~ 71.5	—	Lever	Basic
B	(Approx. 11.1)	1,600	71.9 ~ 75.1	—	Lever	
C	(Approx. 11.3)	1,300	(74.4 ~ 77.6)	—	Lever	
D	(Approx. 11.15)	650	(51.9 ~ 55.1)	—	Lever	
E	11.5	500	(53.0 ~ 57.0)	—	Lever	
I	R ₂ (14.5)	150	87.0 ~ 103.0	—	Lever	

5. Timing Advance Specification :

Pump Speed (r.p.m)	1,250	1,350	1,400	1,600			
Advance Angle (deg.)	Below 0.5	Below 1.1	Below 1.6	Finish 4~5			

3. GOVERNOR ADJUSTMENT

101401-0270 2/4

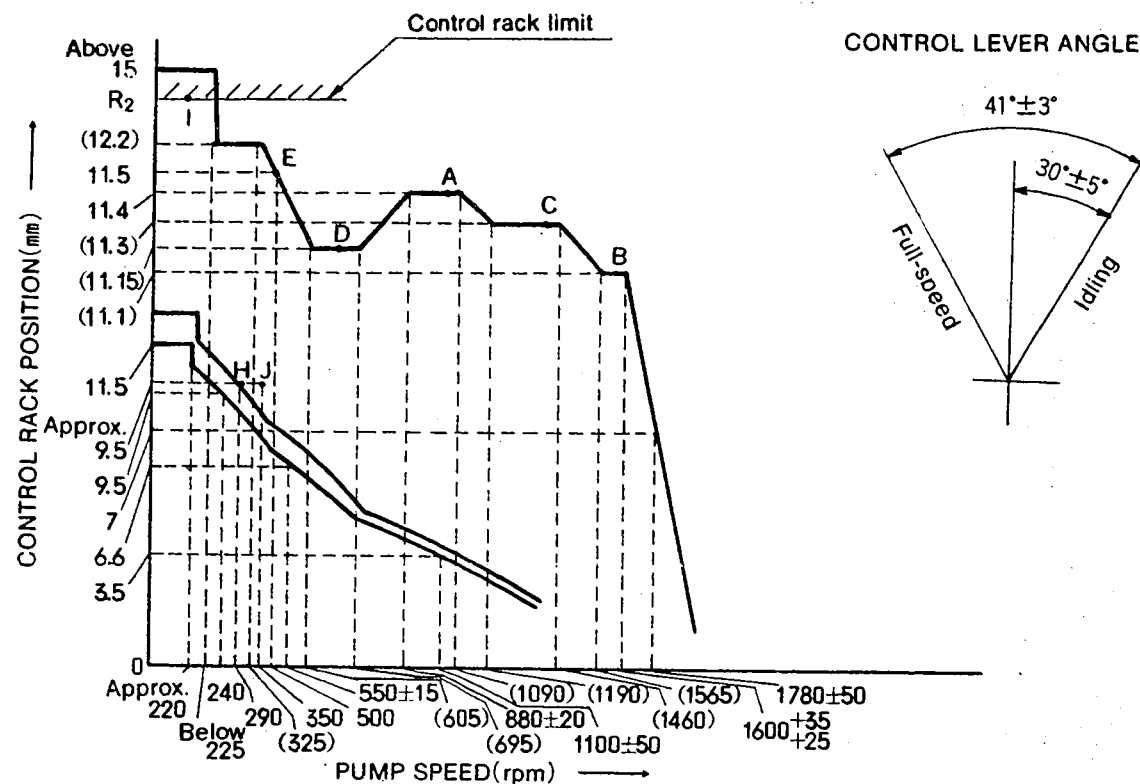

Idling Adjustment

Item	Pump Speed (rpm)	Rack Position (mm)	Remarks
Idling Lever Position: Temporary Setting	80~100	11.5	• Adjust using screw ①.
Idling Position Setting	240	9.5	• Adjust using spring capsule ①.
Governor Spring Contact Adjustment	535~565	6.6	• Adjust the governor shaft position.
	1050~1150	3.5	• Confirm
Setting the Idling Lever Position	290	Approx.9.5	• Adjust using screw ①.
	—	—	• Confirm the control lever angle (25°~35°)

■ Full Load Adjustment (Torque Cam No. 34)

Item	Pump Speed (rpm)	Rack Position (mm)	Remarks
Full Speed Lever Position: Temporary Setting	Approx.1600	(11.1)	• Adjust using screw ③. (Do not enter governor control range)
Full Load Position Adjustment	950	11.4	• Adjust using screw ④.
Torque Cam Position Adjustment	500	11.5	• Adjust using screw ⑤.
	(325)	(12.2)	• Confirm
	(605)	(11.15)	• "
	(695)	(11.15)	• "
	860~900	11.4	• "
	(1090)	11.4	• "
	(1190)	(11.3)	• "
	(1460)	(11.3)	• "
	(1565)	(11.1)	• "
Confirm injection quantity at points A to E.			
Maximum Speed control Adjustment	1625~1635	(11.1)	• Adjust using screw ③.
	1730~1830	7	• Confirm
	—	—	• After adjustment, confirm that the control lever angle is 38°~44°
Confirming Excess Fuel Limit for Engine Starting	350	Approx.9.5	• Set the control lever at point J .
	0	Above 12	• Confirm
	0	Above 15	• Move the control lever to the "full-speed" position and then confirm the control rack position.
Confirm the Black Smoke Limit	Fix the control lever at point H. Then, operate the pump at 240 rpm. Confirm that the control rack does not move beyond 12.2 mm. When the control lever is moved to the "full-speed" position again increase the pump speed and confirm that the control rack starts to move from a pump speed of 325 rpm.		
Rack Limiter Adjustment	0	14.5	• Fix the control rack using screw Part No. 157954-3700
	Measure the depth of the control rack cap. Then, adjust screw ⑥ so that it equals the depth of the rack cap and install the rack cap. Confirm injection quantity at point I .		

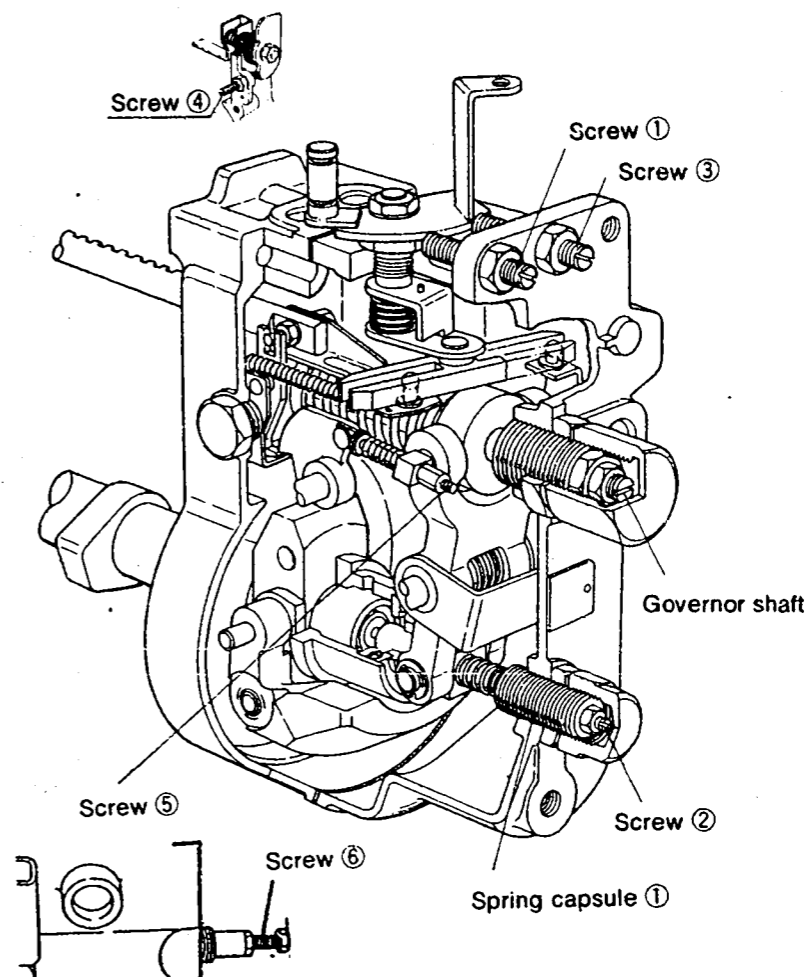

■ Timing Setting

At No. 1 plunger's beginning of injection position.
B.D.T.C. : 13°

Pump center line

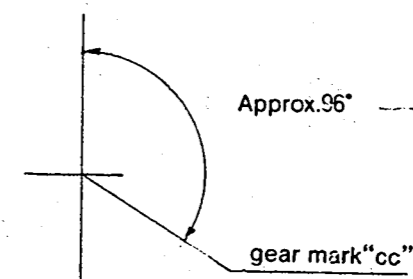

INJ. PUMP CALIBRATION DATA

ENGINE MODEL 4BD1

BOSCH No. 9 400 610 049
 DKKC No. 101401-0590
 Date: 20. Nov. 1986
 Company: ISUZU
 No. 8-94178-719-0

Injection pump : PES4A 101040-8450 Governor : EP/RLD 105931-2102 Timing device : EP/SCDM 105670-0180

1. Test Conditions :

Pump rotation : clockwiseviewed from drive side
 Nozzle & Nozzle Holder Ass'y : 105780-0000 (BOSCH Type No.DN12SD12) Nozzle Holder : 105780-2080 (BOSCH Type No.EF8511/9A)
 Nozzle opening pressure : 175 Kg/cm² Transfer pump pressure : 1.6 Kg/cm²
 Injection pipe : Inner Dia. 2 mm X Outer Dia. 6 mm - Length 600 mm
 Test Oil : ISO4113 or SAE Standard Test Oil (SAE J967d) Oil Temp. : 40^{±5} °C
 Overflow valve opening pressure : 1.6 Kg/cm²

2. Injection Timing :

Pre-stroke : No. 1 Plunger 3.6 ±0.05mm
 Note : Adjust with control rod position of mm
 Injection order : 1 ~ 3 ~ 4 ~ 2 (interval : 90° ±30')

Plungers are numbered from the Drive side.

Tappet clearance : Bolt adjustment type : More than 0.3mm for all cylinders.
 Shim adjustment type : Manually rotate the camshaft 2~3 times and confirm that it rotates smoothly.

4. Injection Quantity :

Adjusting Point	Rod Position (mm)	Pump Speed (r.p.m)	Injection Q'ty (cc/1000 strokes)	Max. var bet. cyl (%)	Fixed	Remarks
	11.2	950	65.1 ~ 68.3	±2.5	Rack	Basic
H	Approx. 9.5	290	6.7 ~ 9.3	±14	Rack	
A	R ₁ (11.2)	950	65.7 ~ 67.7	—	Lever	Basic
B	R ₁ -0.4	1,600	(61.7 ~ 64.9)	—	Lever	
C	R ₁ -0.1	1,300	(69.1 ~ 72.3)	—	Lever	
D	R ₁ -0.25	650	(48.0 ~ 51.2)	—	Lever	
E	R ₁ -0.1	500	(47.0 ~ 51.0)	—	Lever	
I	(14.5)	150	95.0 ~ 103.0	—	Lever	Control rack limit

5. Timing Advance Specification :

Pump Speed (r.p.m)	1,000~1,100	1600				
Advance Angle (deg.)	Start	Finish 4~5				

3. GOVERNOR ADJUSTMENT

101401-0590 2/4

CONTROL LEVER ANGLE

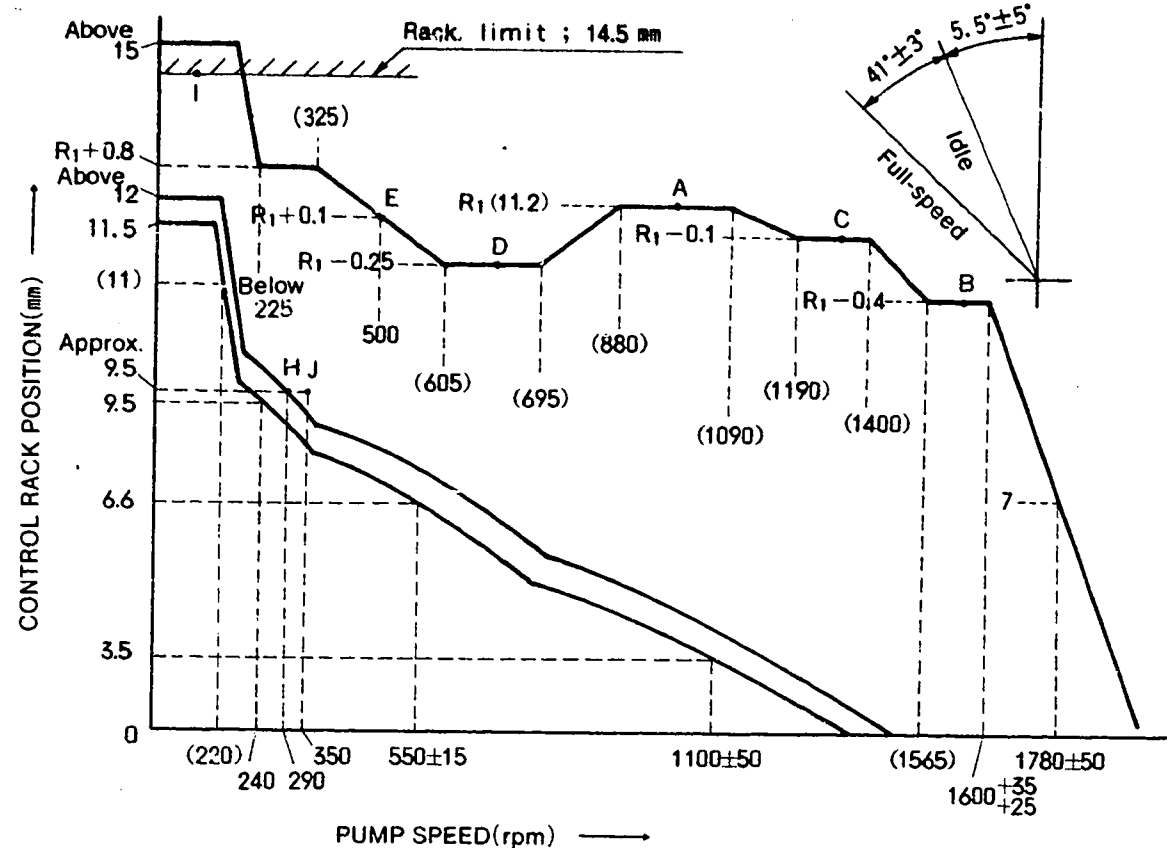

Idling Adjustment

Item	Pump Speed (rpm)	Rack Position (mm)	Remarks
Idling Lever Position: Temporary Setting	80~100	11.5	• Adjust using screw ①.
Idling Position Setting	240 (220)	9.5 (11)	• Adjust using spring capsule ①. • Adjust using screw ②.
Governor Spring Contact Adjustment	535~565 1050~1150	6.6 3.5	• Adjust the governor shaft position. • Confirm
Setting the Idling Lever Position	290	Approx.9.5	• Adjust using screw ①. • Confirm the control lever angle (0.5°~10.5°)

101401-0590 3/4

101401-0590 4/4

■ Full Load Adjustment (Torque Cam No. A47)

Item	Pump Speed (rpm)	Rack Position (mm)	Remarks
Full Speed Lever Position: Temporary Setting	Approx.1600	(11.2)-0.4	• Adjust using screw ③. (Do not enter governor control range)
Full Load Position Adjustment	950	(11.2)	• Adjust using screw ④.
Torque Cam Position Adjustment	500	(11.2)+0.1	• Adjust using screw ⑤.
	(325)	(11.2)+0.8	• Confirm
	(605)	(11.2)-0.25	• ✓
	(695)	(11.2)-0.25	• ✓
	(880)	(11.2)	• ✓
	(1090)	(11.2)	• ✓
	(1190)	(11.2)-0.1	• ✓
	(1400)	(11.2)-0.1	• ✓
	(1565)	(11.2)-0.4	• ✓
Confirm injection quantity at points A to E.			
Maximum Speed control Adjustment	1625~1635	(11.2)-0.4	• Adjust using screw ③.
	1730~1830	7	• Confirm • After adjustment, confirm that the control lever angle is 38°~43°
Confirming Excess Fuel Limit for Engine Starting	350	Approx.9.5	• Set the control lever at point J .
	0	Above 12	• Confirm
	0	Above 15	• Move the control lever to the "full-speed" position and then confirm the control rack position.
Confirm the Black Smoke Limit	Fix the control lever at point H. Then, operate the pump at 270 rpm. Confirm that the control rack does not move beyond (11.2)+0.8 mm. When the control lever is moved to the "full-speed" position again increase the pump speed and confirm that the control rack starts to move from a pump speed of 325 rpm.		
Rack Limiter Adjustment	0	14.5	• Fix the control rack using screw Part No. 157954-3700
	Measure the depth of the control rack cap. Then, adjust screw ⑥ so that it equals the depth of the rack cap and install the rack cap. Confirm injection quantity at point I .		

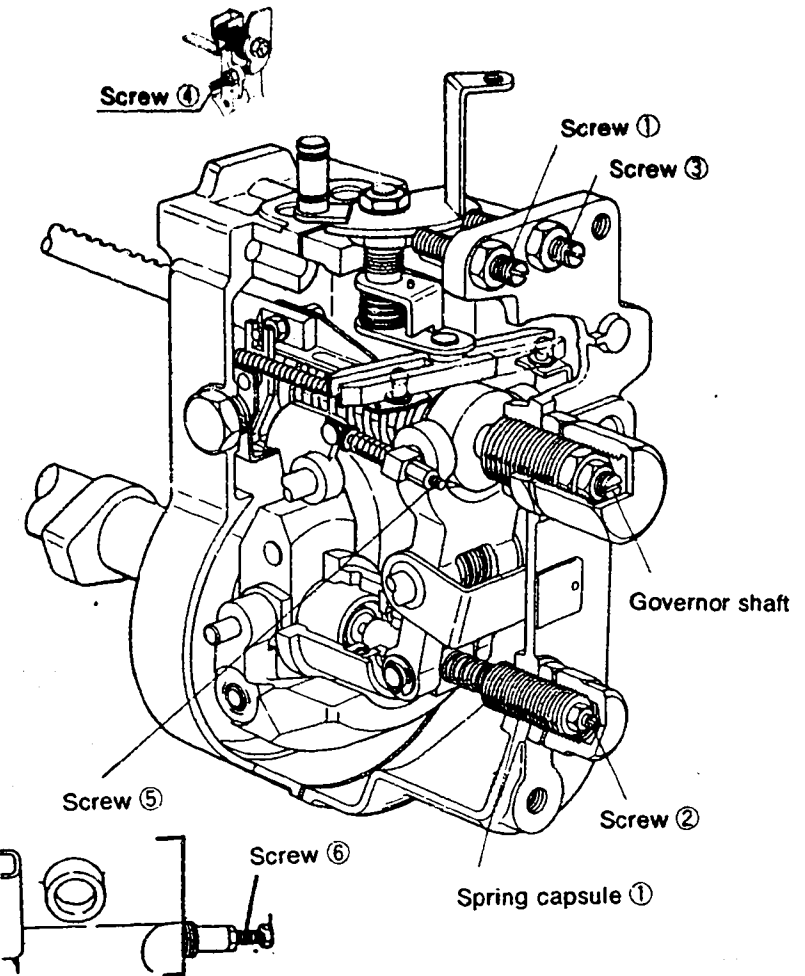

■ Timing Setting

At No. 1 plunger's beginning of injection position.
B.D.T.C. : 13°

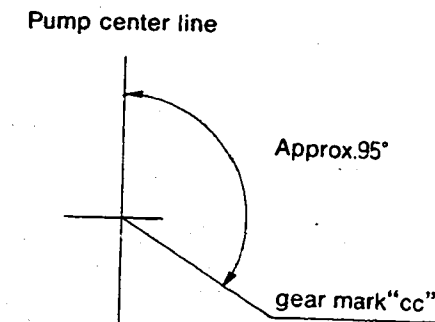

INJ. PUMP CALIBRATION DATA

ENGINE MODEL C240P-3

BOSCH No. 9 400 610 000
 DKKC No. 101431-0580
 Date: 20.Nov.1988
 Company: ISUZU
 No. 515601-0232

Injection pump : PES4A 101043-9170 Governor : EP/RSV 105410-3610 Timing device : EP/SCD 105621-0370

1. Test Conditions :

Pump rotation : Counter clockwise viewed from drive side

Nozzle & Nozzle Holder Ass'y : 105780-0000 (BOSCH Type No.DN12SD12) Nozzle Holder : 105780-2080 (BOSCH Type No.EF8511/9A)
 Nozzle opening pressure : 175 Kg/cm² Transfer pump pressure : 1.6 Kg/cm²

Injection pipe :
 Inner Dia. 2 mm X Outer Dia. 6 mm - Length 600 mm

Test Oil : ISO4113 or SAE Standard Test Oil (SAE J967d) Oil Temp. : 40^{±5} °C

Overflow valve opening pressure : Kg/cm²

2. Injection Timing :

Pre-stroke : No. 1 Plunger 2.25 ±0.05mm

Note : Adjust with control rod position of mm

Injection order : 1 ~ 3 ~ 4 ~ 2 ~ 1 (interval : 90 °±30°)

Plungers are numbered from the Drive side.

Tappet clearance : Bolt adjustment type ; More than 0.3mm for all cylinders.

Shim adjustment type ; Manually rotate the camshaft 2~3 times and confirm that it rotates smoothly.

4. Injection Quantity :

Adjusting Point	Rod Position (mm)	Pump Speed (r.p.m)	Injection Q'ty (cc/1000 strokes)	Max. var bet. cyl (%)	Fixed	Remarks
A	12.6	1,450	42.0 ~ 44.0	±4	Rack	Basic
H	7.6	350	6.9 ~ 9.1	±2.5	Rack	
B	12.6	750	39.7 ~ 42.9	±14	Lever	Basic

5. Timing Advance Specification :

Pump Speed (r.p.m)	450~550	800	1,050	1,500	1,750		
Advance Angle (deg.)	Start	0.5~1.5	1.2~2.7	3.9~4.9	Finish	5.5~6.5	

3. GOVERNOR ADJUSTMENT

101431-0580 2/4

CONTROL LEVER ANGLE

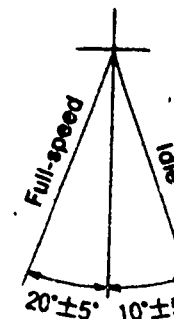
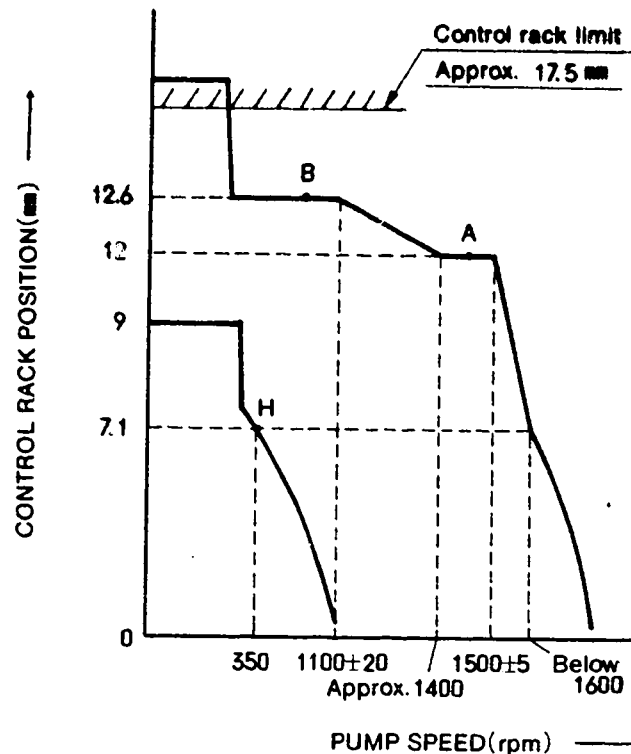

■ Note

- Before adjustment, remove the idling sub spring and the torque control spring.
- Move the control lever fully in the stop direction, and set the minimum-speed stopper bolt so that the control rack position is 0.5~1.0 mm.

■ Adjustment

Item	Pump Speed (rpm)	Rack Position (mm)	Remarks
Full-load Adjustment (Temporary)	1495~1505	12.0	• Adjust using screw ①
	1450	12.0	• Adjust using screw ②
Torque Control Spring Adjustment	750	12.6	• Adjust using spring capsule ①
	1080~1120	12.6	• Confirm
	Approx.1400	12.0	• Confirm
			• Confirm the torque control stroke is 0.6 mm.

101431-0580 3/4

101431-0580 4/4

Item	Pump Speed (rpm)	Rack Position (mm)	Remarks
Idling Adjustment	0	9.0	<ul style="list-style-type: none"> • Fix the control lever • Adjust using spring capsule ② • Confirm
	350	7.1	
	—	—	
Maximum-speed Adjustment	1495~1505	12.0	<ul style="list-style-type: none"> • Adjust using screw ① • Confirm speed droop • Confirm • Confirm
	Below 1600	7.1	
	—	—	
Full-load Adjustment (Install the cover on governor cover)	1450	12.0	• Adjust using screw ②
Control Lever Angle Measurement	<ul style="list-style-type: none"> • Measure the control lever angle at the "idling" and "full" positions. • When the control lever is depressed toward the "full" position, replace the shifter's shim with a thicker one. • When the control lever is depressed toward the "idling" position, replace the shifter's shim with a thinner one. 		
Rack Limiter Adjustment	0	Approx.17.5	• Adjust using screw

■ Timing Setting

At No.1 plunger's beginning of injection position

B.T.D.C : 14°

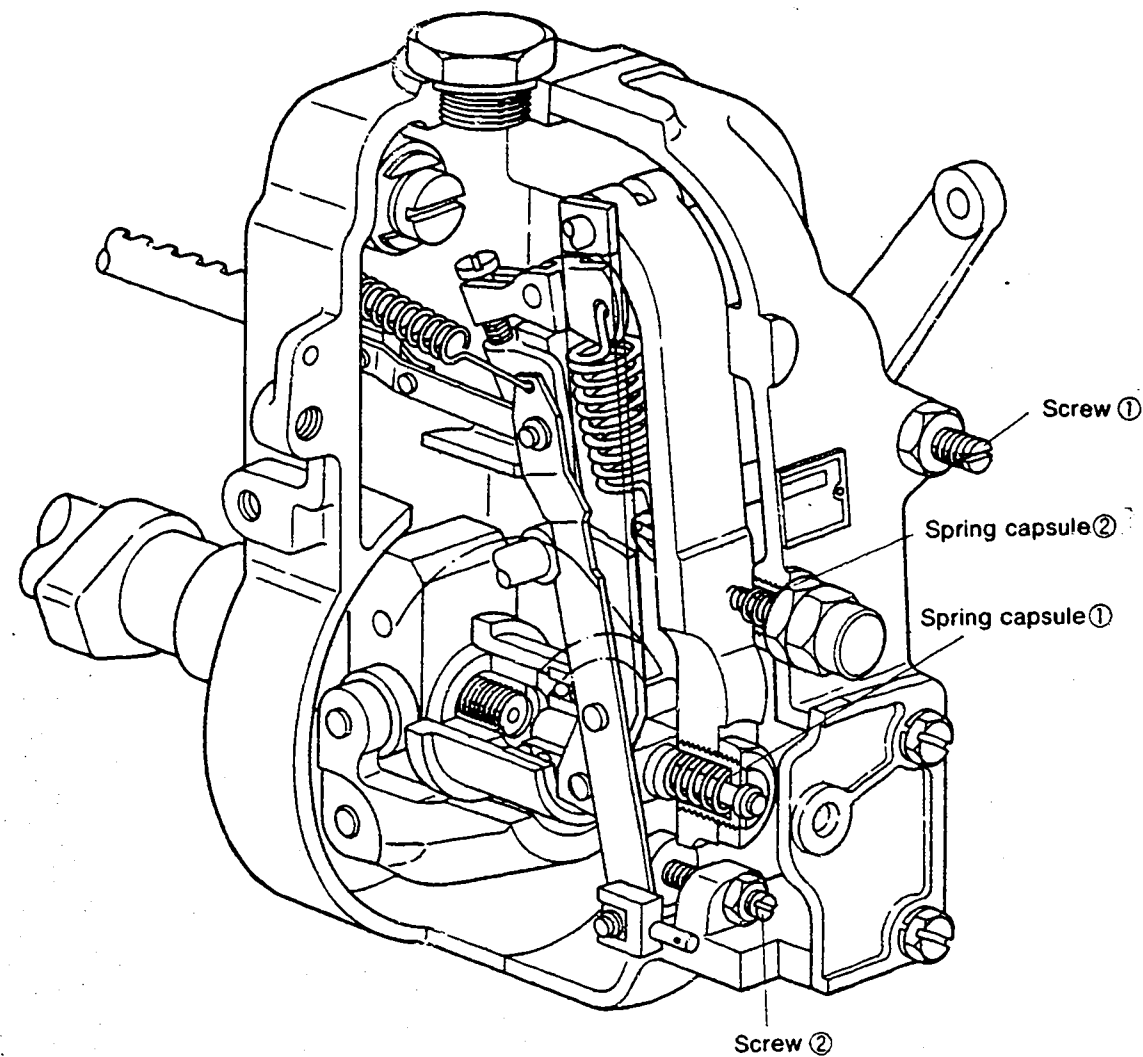
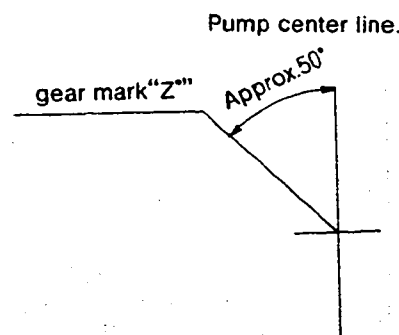

INJ. PUMP CALIBRATION DATA

ENGINE MODEL **SD22**

BOSCH No. 9 400 610 027

DKKC No. 101431-9070

Date: 20 Nov. 1988

Company: NISSAN DIESEL

No. 1670037702

Injection pump : PES4A
101043-8100

Governor : EP/MZ
105520-6340

Timing device : EP/SCD
105622-0240

1. Test Conditions :

Pump rotation : clockwise viewed from drive side

Nozzle & Nozzle Holder Assy : 105780-0000 (BOSCH Type No. DN12SD12)
Nozzle Holder : 105780-2080 (BOSCH Type No. EF8511/9A)

Nozzle opening pressure : 175 Kg/cm² Transfer pump pressure : 1.6 Kg/cm²

Injection pipe :

Inner Dia. 2 mm X Outer Dia. 6 mm - Length 600 mm

Test Oil : ISO4113 or SAE Standard Test Oil (SAE J967d) Oil Temp. : 40^{±5} °C

Overflow valve opening pressure : Kg/cm²

2. Injection Timing :

Pre-stroke : No. 1 Plunger 2.3 ±0.05mm

Note : Adjust with control rod position of mm

Injection order : 1 ~ 3 ~ 4 ~ 2 (interval : 90° ±30')

Plungers are numbered from the Drive side.

Tappet clearance : Bolt adjustment type ; More than 0.3mm for all cylinders.

: Shim adjustment type ; Manually rotate the camshaft 2~3 times and confirm that it rotates smoothly.

4. Injection Quantity :

Adjusting Point	Rod Position (mm)	Pump Speed (r.p.m)	Injection Q'ty (cc/1000 strokes)	Max. var bet. cyl (%)	Fixed	Remarks
A	15	800	36.3 ~ 38.3	±2.5	Rack	Basic
B	14	1,700	35.7 ~ 38.9	±4	Rack	
A	12	800	36.3 ~ 38.3	—	Lever	Basic
C	9	1,700	6.2 ~ 7.8	±7.5	Lever	
D	10.8	300	6.5 ~ 8.9	±15	Lever	

5. Timing Advance Specification :

Pump Speed (r.p.m)	450~550	700	900	1,100	1,300	1,500
Advance Angle (deg.)	Start	0.5~1.5	1.5~2.5	2.5~3.5	3.5~4.5	Finish 4.5~5.5

3. GOVERNOR ADJUSTMET

101431-9070 2/4

3-1. PNEUMATIC GOVERNOR

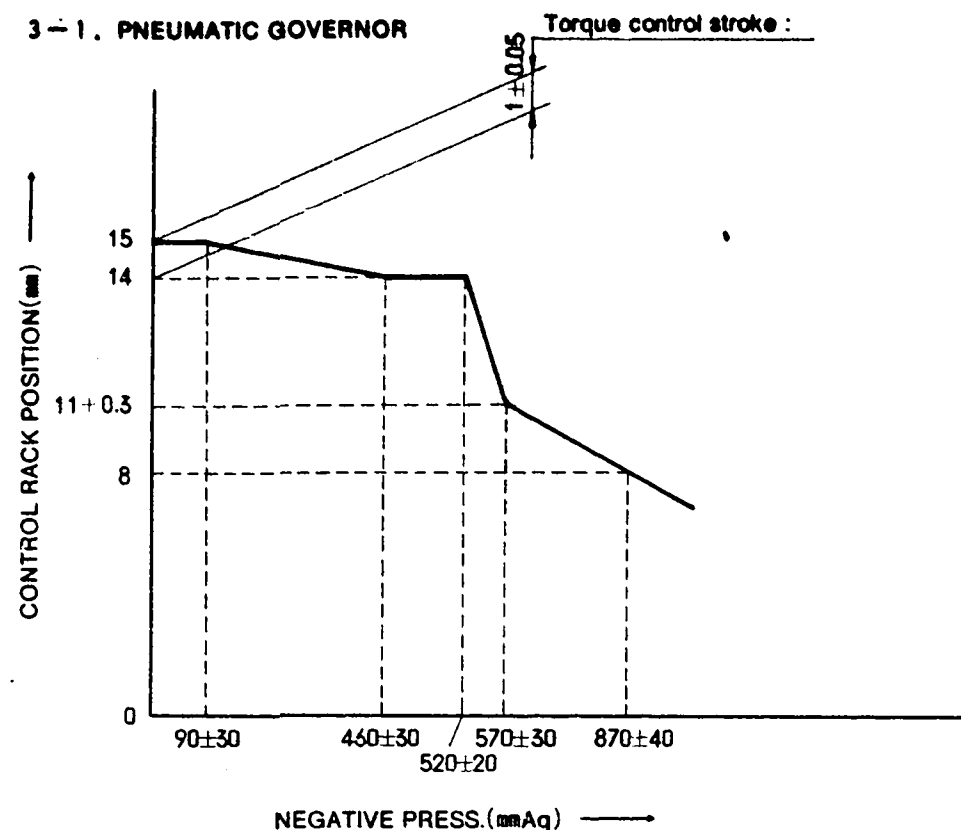

■ Air Tightness Test

1. Increase the pressure of the pneumatic governor's negative pressure chamber to 500 mmAq at a pump speed of 500 rpm and a control rack position of 15 mm.
2. Then, confirm that it takes 10 seconds or more for the negative pressure to fall from 500 mmAq to 480 mmAq.

■ Adjustment

1. Pneumatic Governor (Pump Speed : 500 rpm)

Item	Negative Press. (mmAq)	Rack Position (mm)	Remarks
Smoke Set Screw Adjustment	0	15	• Adjust using spring capsule ①.
Torque Control Adjustment	60~120	15	• Adjust thickness of shim ①.
	430~490	14	• Adjust thickness of shim ②.
③ Confirm	—	—	• Inspection : 1 ± 0.05 mm
④ Confirm torque control stroke	—	—	

101431-9070 3/4

101431-9070 4/4

Item	Negative Press. (mmAq)	Rack Position (mm)	Remarks
High-speed control Adjustment	500~540	14	• Adjust thickness of shim ③.
Idling Adjustment	540~605 830~910	10.7~11.3 8	• Adjust using spring capsule ②. • Confirm

■ Final Adjustment

Smoke Screw Setting			Fuel Injection Quantity Adjustment		
Pump Speed (rpm)	Negative Press. (mmAq)	Injection Q'ty (cc/1000st)	Pump Speed (rpm)	Negative Press. (mmAq)	Injection Q'ty (cc/1000st)
800	0	36.8~37.8	---	---	---
			---	---	---
			---	---	---
			---	---	---
			---	---	---
			---	---	---

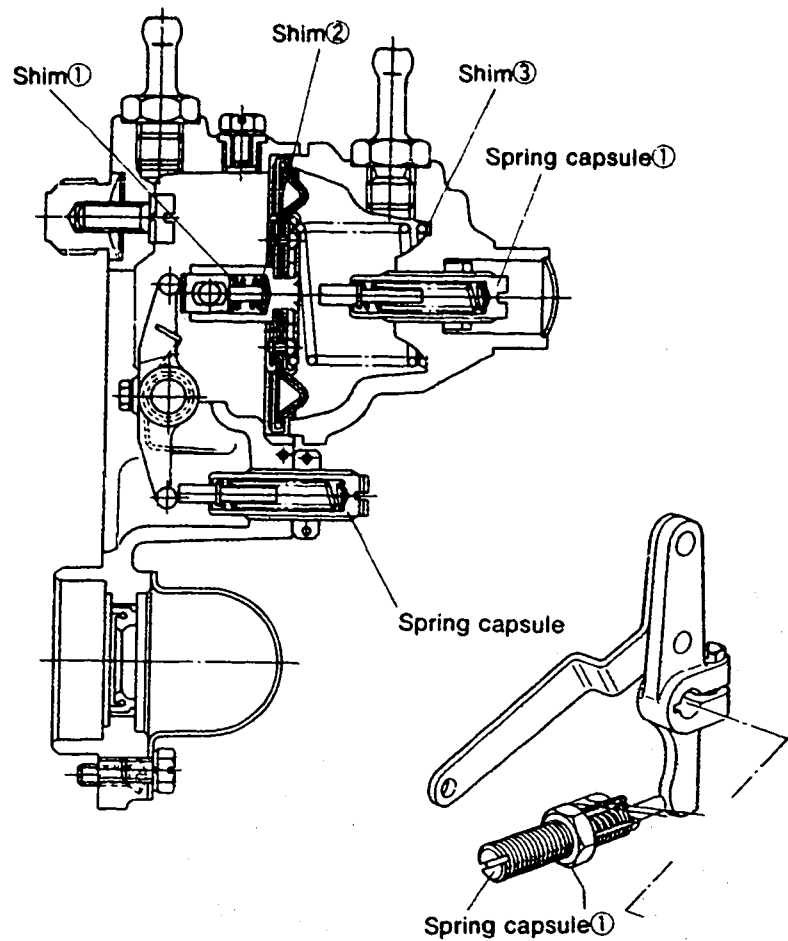

INJ. PUMP CALIBRATION DATA

ENGINE MODEL SD22

BOSCH No. 9 400 810 028
 DKKC No. 101431-9560
 Date: 20 Nov. 1988 [5]
 Company: NISSAN DIESEL
 No. 1670076201

Injection pump : PES4A 101043-8100 Governor : EP/RBD 105542-6470 Timing device : EP/SCD 105622-0240

1. Test Conditions :

Pump rotation : clockwise viewed from drive side
 Nozzle & Nozzle Holder Ass'y : 105780-0000 (BOSCH Type No. DN12SD12) Nozzle Holder : 105780-2080 (BOSCH Type No. EF8511/9A)
 Nozzle opening pressure : 175 Kg/cm² Transfer pump pressure : 1.6 Kg/cm²
 Injection pipe : Inner Dia. 2 mm X Outer Dia. 6 mm - Length 600 mm
 Test Oil : ISO4113 or SAE Standard Test Oil (SAE J967d) Oil Temp. : 40^{±5}°C
 Overflow valve opening pressure : Kg/cm²

2. Injection Timing :

Pre-stroke : No. 1 Plunger 2.3 ±0.05mm
 Note : Adjust with control rod position of mm
 Injection order : 1 ~ 3 ~ 4 ~ 2 (interval : 90° ±30')

Plungers are numbered from the Drive side.

Tappet clearance : Bolt adjustment type : More than 0.3mm for all cylinders.
 Shim adjustment type : Manually rotate the camshaft 2~3 times and confirm that it rotates smoothly.

4. Injection Quantity :

Adjusting Point	Rod Position (mm)	Pump Speed (r.p.m)	Injection Q'ty (cc/1000 strokes)	Max. var bet. cyl (%)	Fixed	Remarks
	12	800	36.3 ~ 38.3	±2.5	Rack	Basic
	11	1,700	35.7 ~ 38.9	±4	Rack	
	12	800	36.3 ~ 38.3	—	Lever	Basic
	6	1,700	6.2 ~ 7.8	±7.5	Lever	
	Approx. 7.7	300	6.4 ~ 8.6	±15	Lever	

5. Timing Advance Specification :

Pump Speed (r.p.m)	450~550	700	900	1,100	1,300	1,500	
Advance Angle (deg.)	Start	0.5~1.5	1.5~2.5	2.5~3.5	3.5~4.5	Finish 4.5~5.5	

3. GOVERNOR ADJUSTMET

101431-9560 2/4

(1) Pneumatic Governor

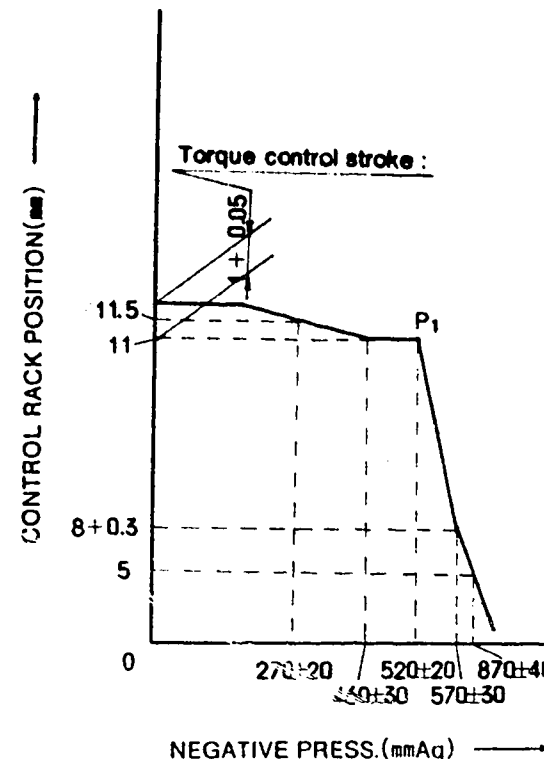

(2) Mechanical Governor

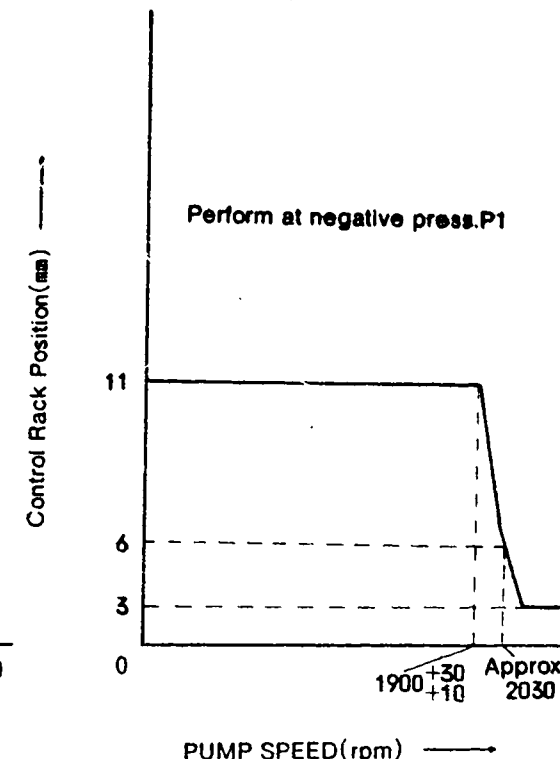

■ Air Tightness Test

- Increase the pressure of the pneumatic governor's negative pressure chamber to 500 mmAq at a pump speed of 500 rpm and a control rack position of 12 mm.
- Then, confirm that it takes 10 seconds or more for the negative pressure to fall from 500 mmAq to 480 mmAq.

■ Adjustment

- Pneumatic Governor (Pump Speed : 500 rpm)

Item	Negative Press. (mmAq)	Rack Position (mm)	Remarks
Smoke Set Screw Adjustment	0	Approx. 12	• Adjust using spring capsule ①.
Torque Control Adjustment	① Adjust point	245~295	• Adjust thickness of shim ①.
	② End of torque control spring movement	430~490	• Adjust thickness of shim ②.
	③ Confirm	—	
	④ Confirm torque control stroke	—	• Inspection : 1 ± 0.05 mm

Item	Negative Press. (mmAq)	Rack Position (mm)	Remarks
High-speed control Adjustment	500~540	11	• Adjust thickness of shim ③.
Idling Adjustment	540~600	7.7~8.3	• Adjust using spring capsule ②.
	840~910	5	• Confirm

2. Mechanical Governor (Negative pressure: *500~540* mmAq).

Item	Pump Speed (rpm)	Rack Position (mm)	Remarks
Maximum Speed Control Adjustment	1910~1930	11	• Adjust using screw ①.
	Approx.2030	6	• Confirm
	Approx.2100	3	• Confirm (Check the fuel injection quantity: below 3 cc/1000st)

■ Final Adjustment

Smoke Screw Setting			Fuel Injection Quantity Adjustment		
Pump Speed (rpm)	Negative Press. (mmAq)	Injection Q'ty (cc/1000st)	Pump Speed (rpm)	Negative Press. (mmAq)	Injection Q'ty (cc/1000st)
800	0	36.8~37.8	—	—	—
			—	—	—
			—	—	—
			—	—	—
			—	—	—
			—	—	—

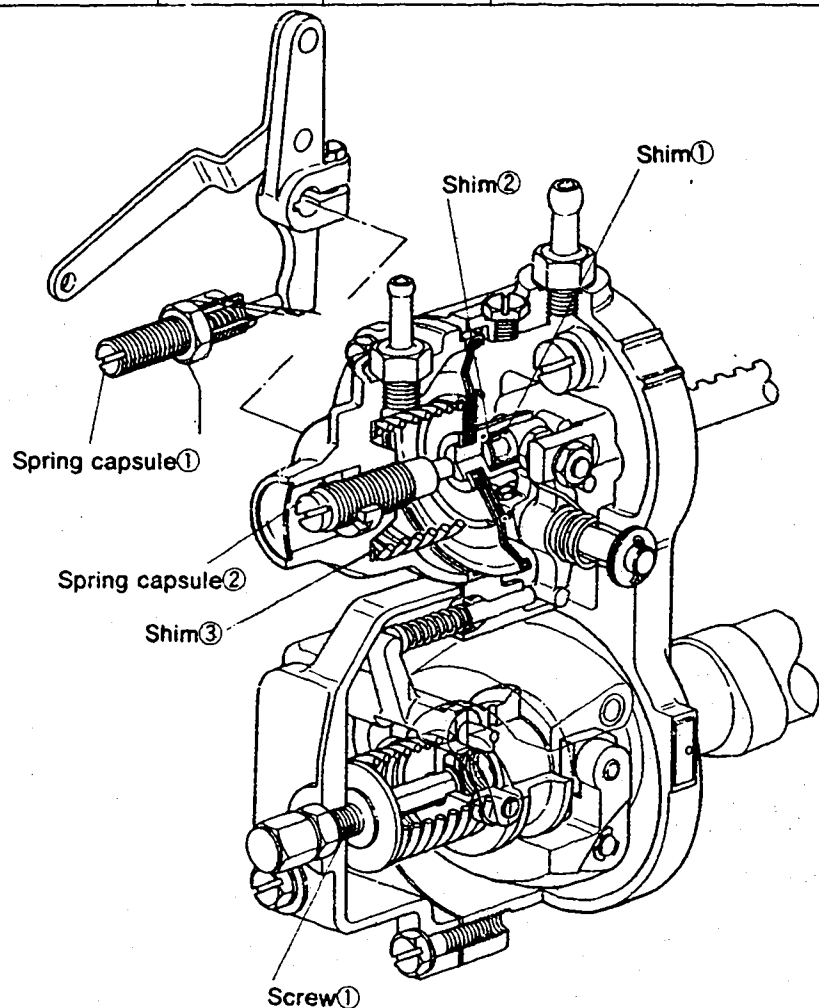

INJ. PUMP CALIBRATION DATA

ENGINE MODEL SD22

BOSCH No. 9 400 610 029
 DKKC No. 101431-9580
 Date: 20 Nov. 1988 5
 Company: NISSAN DIESEL
 No. 16700P0704

Injection pump : PES4A Governor : EP/RBD Timing device : EP/SCD
 101043-8100 105542-6520 105622-0240

1. Test Conditions :

Pump rotation : clockwise viewed from drive side

Nozzle & Nozzle Holder Ass'y : 105780-0000 (BOSCH Type No. DN12SD12)
 Nozzle Holder : 105780-2080 (BOSCH Type No. EF8511/9A)
 Nozzle opening pressure : 175 Kg/cm² Transfer pump pressure : 1.6 Kg/cm²
 Injection pipe : Inner Dia. 2 mm X Outer Dia. 6 mm - Length 600 mm

Test Oil : ISO4113 or SAE Standard Test Oil (SAE J967d) Oil Temp. : 40^{±5}°C

Overflow valve opening pressure : Kg/cm²

2. Injection Timing :

Pre-stroke : No. 1 Plunger 2.3 ±0.05mm
 Note : Adjust with control rod position of mm

Injection order : 1 ~ 3 ~ 4 ~ 2 (interval : 90° ± 30°)
 Plungers are numbered from the Drive side.

Tappet clearance : Bolt adjustment type : More than 0.3mm for all cylinders.
 Shim adjustment type : Manually rotate the camshaft 2~3 times and confirm that it rotates smoothly.

4. Injection Quantity :

Adjusting Point	Rod Position (mm)	Pump Speed (r.p.m)	Injection Q'ty (cc/1000 strokes)	Max. var bet. cyl (%)	Fixed	Remarks
	12	800	36.3 ~ 38.3	±2.5	Rack	Basic
	11	1,700	35.7 ~ 38.9	±4	Rack	
	12	800	36.3 ~ 38.3	—	Lever	Basic
	6	1,700	6.5 ~ 8.0	±7.5	Lever	
	Approx. 7.7	300	6.4 ~ 8.6	±15	Lever	

5. Timing Advance Specification :

Pump Speed (r.p.m)	450~550	700	900	1,100	1,300	1,500	
Advance Angle (deg.)	Start	0.5~1.5	1.5~2.5	2.5~3.5	3.5~4.5	Finish	4.5~5.5

3. GOVERNOR ADJUSTMET

101431-9580 2/4

(1) Pneumatic Governor

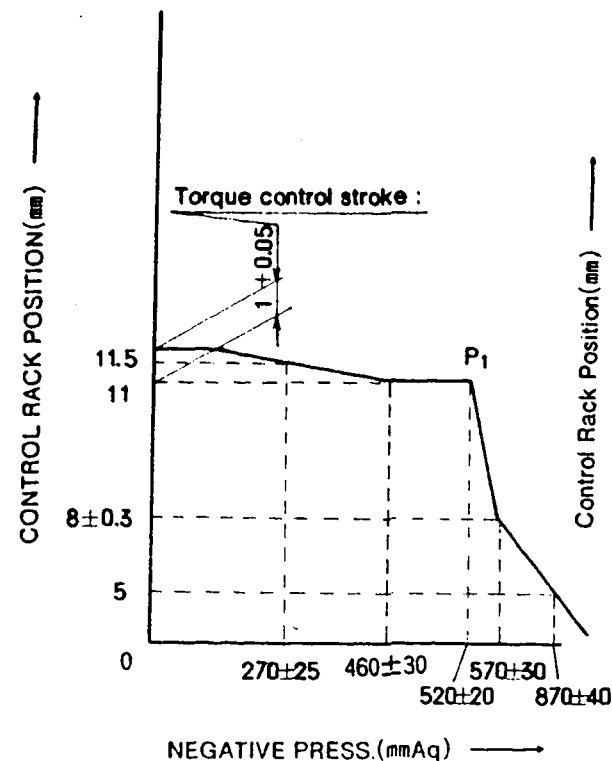

(2) Mechanical Governor

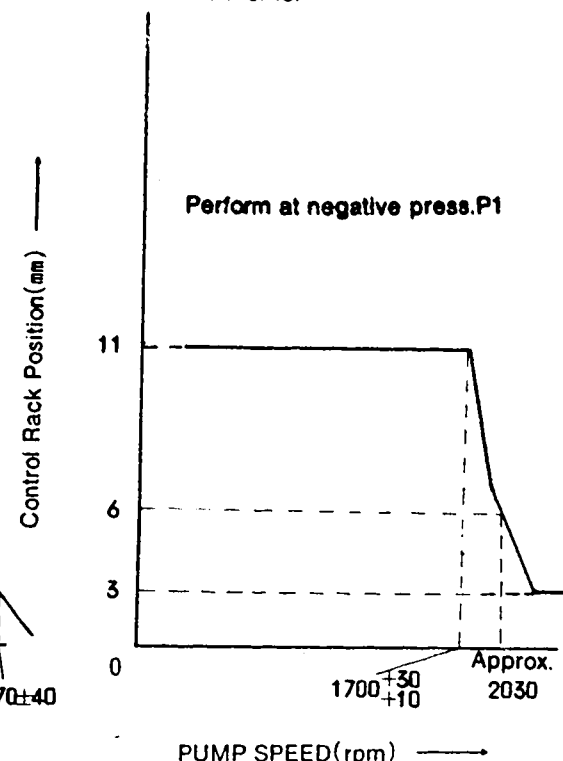

■ Air Tightness Test

- Increase the pressure of the pneumatic governor's negative pressure chamber to 500 mmAq at a pump speed of 500 rpm and a control rack position of 11.5 mm.
- Then, confirm that it takes 10 seconds or more for the negative pressure to fall from 500 mmAq to 480 mmAq.

■ Adjustment

- Pneumatic Governor (Pump Speed : 500 rpm)

Item	Negative Press. (mmAq)	Rack Position (mm)	Remarks
Smoke Set Screw Adjust-ment	0	12	• Adjust using spring capsule ①.
Torque Control Adjustment			
① Adjust point	245~295	11.5	• Adjust thickness of shim ①.
② End of torque control spring movement	430~490	11.1	• Adjust thickness of shim ②.
③ Confirm	—	—	
④ Confirm torque control stroke	—	—	• Inspection : 1±0.05 mm

Item	Negative Press. (mmAq)	Rack Position (mm)	Remarks
High-speed control Adjustment	500~540	11	• Adjust thickness of shim ③.
Idling Adjustment	540~600	7.7~8.3	• Adjust using spring capsule ②. • Confirm
	830~910	5	

2. Mechanical Governor (Negative pressure: ~~500~540~~ mmAq)

Item	Pump Speed (rpm)	Rack Position (mm)	Remarks
Maximum Speed Control Adjustment	1910~1930	11	• Adjust using screw ①.
	Approx. 2036	6	• Confirm
	Approx. 2100	3	• Confirm (Check the fuel injection quantity: below 3 cc/1000st)

■ Final Adjustment

Smoke Screw Setting			Fuel Injection Quantity Adjustment		
Pump Speed (rpm)	Negative Press. (mmAq)	Injection Q'ty (cc/1000st)	Pump Speed (rpm)	Negative Press. (mmAq)	Injection Q'ty (cc/1000st)
800	0	36.8~37.8	—	—	—
			—	—	—
			—	—	—
			—	—	—
			—	—	—
			—	—	—

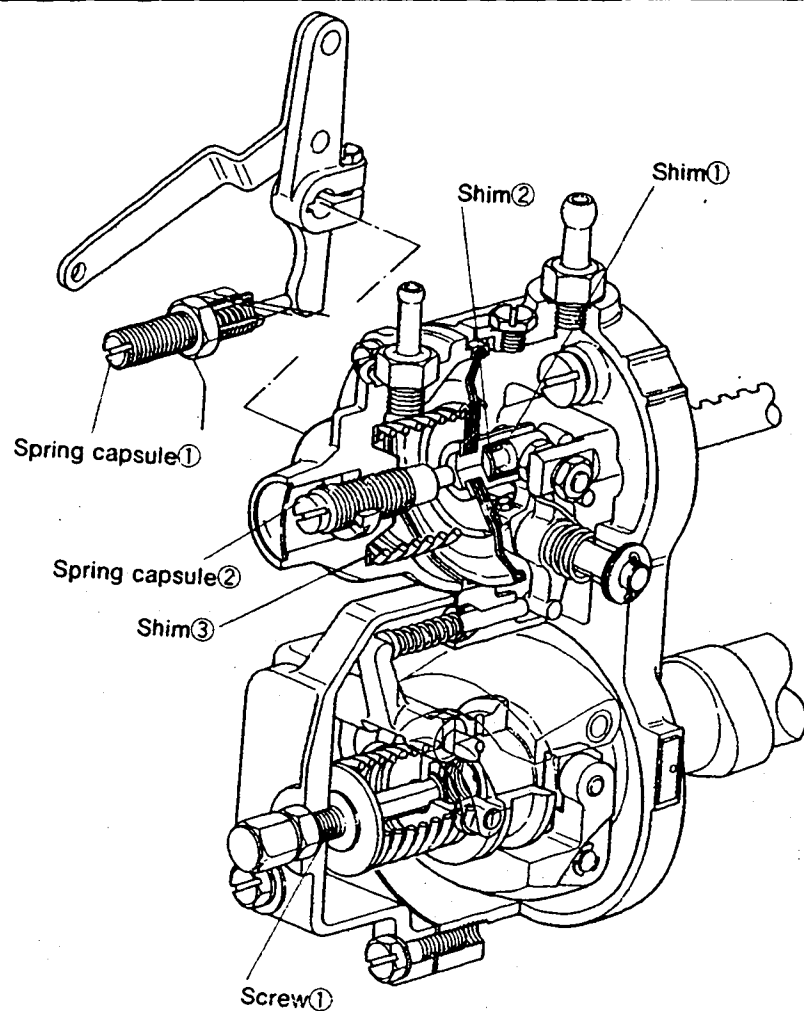

INJ. PUMP CALIBRATION DATA

ENGINE MODEL SD22

BOSCH No.9 400 610 001
 DKKC No. 101431-9770
 Date: 20.Nov.1986 [5]
 Company: NISSAN DIESEL
 No. 16700Y1402

Injection pump : PES4A 101043-9350 Governor : EP/RBD 105542-6761 Timing device : EP/SCD 105622-0240

1. Test Conditions :

Pump rotation : clockwise viewed from drive side

Nozzle & Nozzle Holder Ass'y : 105780-0000 (BOSCH Type No.DN12SD12) Nozzle Holder : 105780-2080 (BOSCH Type No.EF8511/9A)
 Nozzle opening pressure : 175 Kg/cm² Transfer pump pressure : 1.6 Kg/cm²

Injection pipe : Inner Dia. 2 mm X Outer Dia. 6 mm - Length 600 mm

Test Oil : ISO4113 or SAE Standard Test Oil (SAE J967d) Oil Temp. : 40⁺⁵ °C

Overflow valve opening pressure : Kg/cm²

2. Injection Timing :

Pre-stroke : No. 1 Plunger 2.3 ±0.05mm
 Note : Adjust with control rod position of mm

Injection order : 1 ~ 3 ~ 4 ~ 2 (interval : 90° ±30°)
 Plungers are numbered from the Drive side.

Tappet clearance : Bolt adjustment type : More than 0.3mm for all cylinders.
 : Shim adjustment type : Manually rotate the camshaft 2~3 times and confirm that it rotates smoothly.

4. Injection Quantity :

Adjusting Point	Rod Position (mm)	Pump Speed (r.p.m)	Injection Q'ty (cc/1000 strokes)	Max. var bet. cyl (%)	Fixed	Remarks
	12	800	36.3 ~ 38.3	±2.5	Rack	Basic
	11	1,700	35.7 ~ 38.9	±4	Rack	
	6	1,700	6.2 ~ 7.8	±7.5	Rack	
	Approx. 7.7	300	6.4 ~ 8.6	±15	Rack	

5. Timing Advance Specification :

Pump Speed (r.p.m)	500	550	700	900	1,100	1,300	1,500
Advance Angle (deg.)	Below 0.5	Below 0.7	0.5~1.5	1.5~2.5	2.5~3.5	3.5~4.5	Finish 4.5~5.5

3. GOVERNOR ADJUSTMET

101431-9770 2/4

(1) Pneumatic Governor

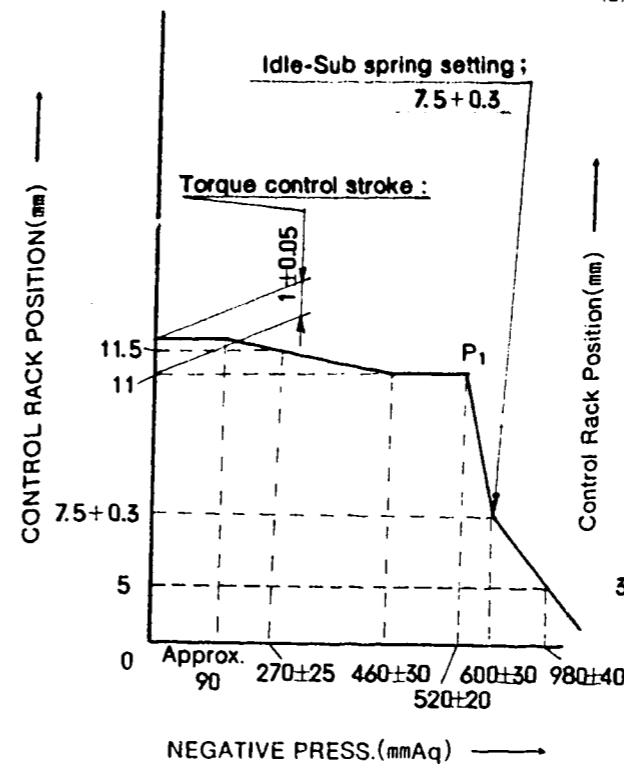

(2) Mechanical Governor

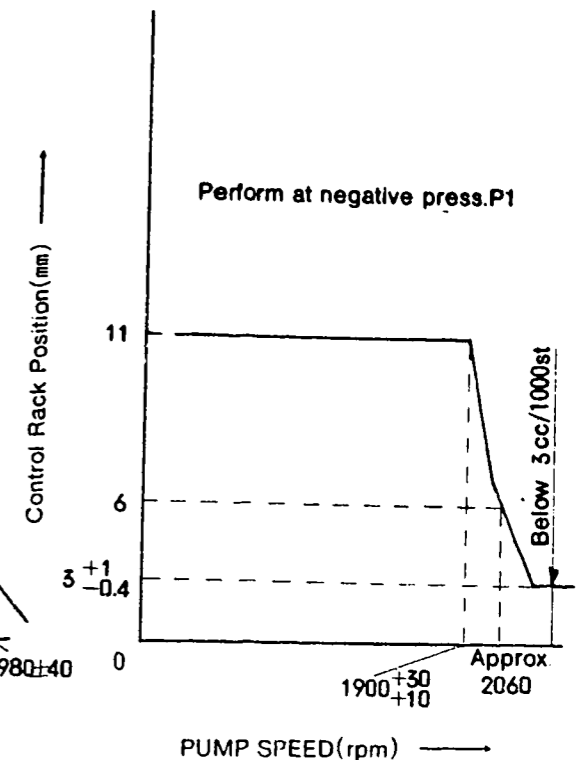

■ Air Tightness Test

1. Increase the pressure of the pneumatic governor's negative pressure chamber to 500 mmAq at a pump speed of 500 rpm and a control rack position of 12 mm.
2. Then, confirm that it takes 10 seconds or more for the negative pressure to fall from 500 mmAq to 480 mmAq.

■ Adjustment

1. Pneumatic Governor (Pump Speed : 500 rpm)

Item	Negative Press. (mmAq)	Rack Position (mm)	Remarks
Smoke Set Screw Adjustment	0	12	• Adjust using spring capsule ①.
Torque Control Adjustment			
① Start of torque control spring movement	Approx.90	Approx.12	• Adjust thickness of shim ①.
② End of torque control spring movement	430~490	11	• Adjust thickness of shim ②.
③ Confirm	—	—	
④ Confirm torque control stroke	—	—	• Inspection : 1±0.05 mm

■ Final Adjustment

Item	Negative Press. (mmAq)	Rack Position (mm)	Remarks
High-speed control Adjustment	500~540	11	• Adjust thickness of shim ③.
Idling Adjustment	570~630 940~1020	7.2~7.8 5	• Adjust using spring capsule ②. • Confirm

2. Mechanical Governor (Negative pressure: 500~540 mmAq)

Item	Pump Speed (rpm)	Rack Position (mm)	Remarks
Maximum Speed Control Adjustment	1910~1930	11	• Adjust using screw ①.
	Approx.2060	6	• Confirm
	Approx.2100	2.6~4.0	• Confirm (Check the fuel injection quantity: below 3 cc/1000st)

Smoke Screw Setting			Fuel Injection Quantity Adjustment		
Pump Speed (rpm)	Negative Press. (mmAq)	Injection Q'ty (cc/1000st)	Pump Speed (rpm)	Negative Press. (mmAq)	Injection Q'ty (cc/1000st)
800	0	36.8~37.8	—	—	—
			—	—	—
			—	—	—
			—	—	—
			—	—	—
			—	—	—

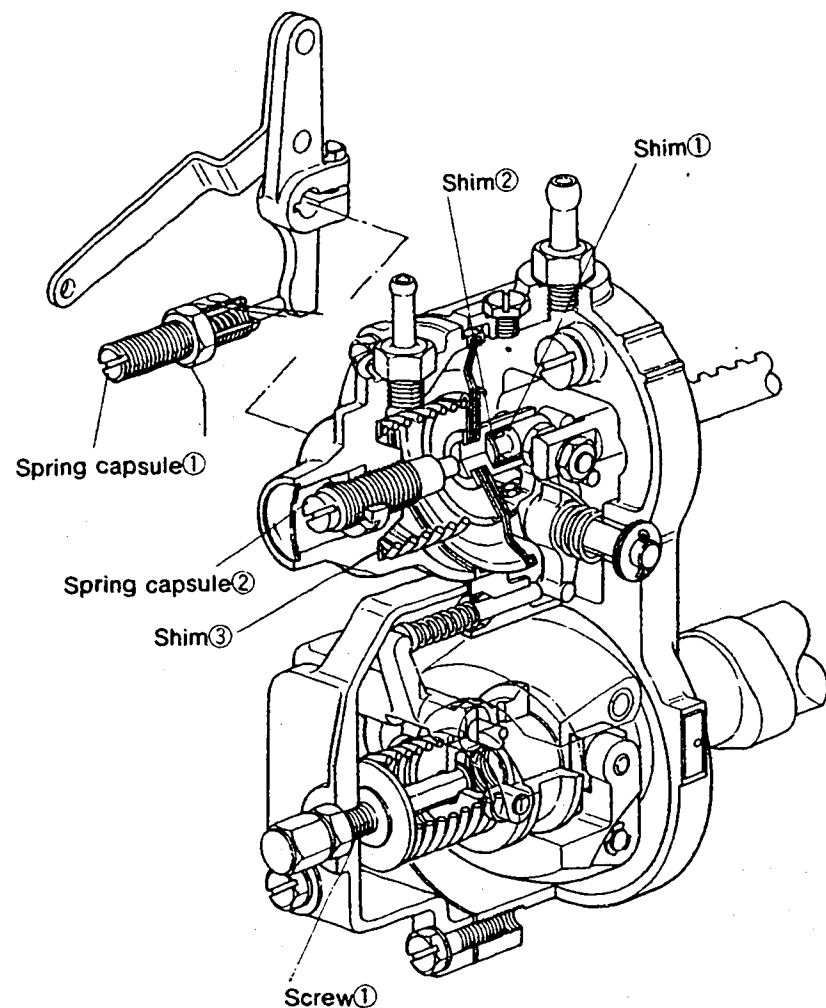

INJ. PUMP CALIBRATION DATA

ENGINE MODEL SD22

BOSCH No.9 400 610 030
 DKKC No. 101431-9850
 Date: 20.Nov.1986 [3]
 Company: NISSAN DIESEL
 No. 16700Y8401

Injection pump : PES4A 101043-8320 Governor : EP/RBD 105542-6871 Timing device : EP/SCD 105622-0240

1. Test Conditions :

Pump rotation : clockwise viewed from drive side

Nozzle & Nozzle Holder Ass'y : 105780-0000 (BOSCH Type No.DN12SD12) Nozzle Holder : 105780-2080 (BOSCH Type No.EF8511/9A)

Nozzle opening pressure : 175 Kg/cm² Transfer pump pressure : 1.6 Kg/cm²

Injection pipe : Inner Dia. 2 mm X Outer Dia. 6 mm - Length 600 mm

Test Oil : ISO4113 or SAE Standard Test Oil (SAE J967d) Oil Temp. : 40^{±5}°C

Overflow valve opening pressure : Kg/cm²

2. Injection Timing :

Pre-stroke : No. 1 Plunger 2.3 ±0.05mm
 Note : Adjust with control rod position of mm

Injection order : 1 ~ 3 ~ 4 ~ 2 (interval : 90° ±30')

Plungers are numbered from the Drive side.

Tappet clearance : Bolt adjustment type : More than 0.3mm for all cylinders.
 Shim adjustment type : Manually rotate the camshaft 2~3 times and confirm that it rotates smoothly.

4. Injection Quantity :

Adjusting Point	Rod Position (mm)	Pump Speed (r.p.m)	Injection Q'ty (cc/1000 strokes)	Max. var bet. cyl (%)	Fixed	Remarks
	12	800	36.3 ~ 38.3	±2.5	Rack	Basic
	11	1,700	35.8 ~ 38.9	±4	Rack	
	12	800	36.3 ~ 38.3	±2.5	Lever	Basic
	6	1,700	6.2 ~ 7.8	±7.5	Lever	
	Approx. 7.7	300	6.4 ~ 8.6	±15	Lever	

5. Timing Advance Specification :

Pump Speed (r.p.m)	500	550	700	900	1,100	1,300	1,500
Advance Angle (deg.)	Below 0.5	Below 0.7	0.5~1.5	1.5~2.5	2.5~3.5	3.5~4.5	Finish 4.5~5.5

3. GOVERNOR ADJUSTMET

101431-9850 2/4

(1) Pneumatic Governor

(2) Mechanical Governor

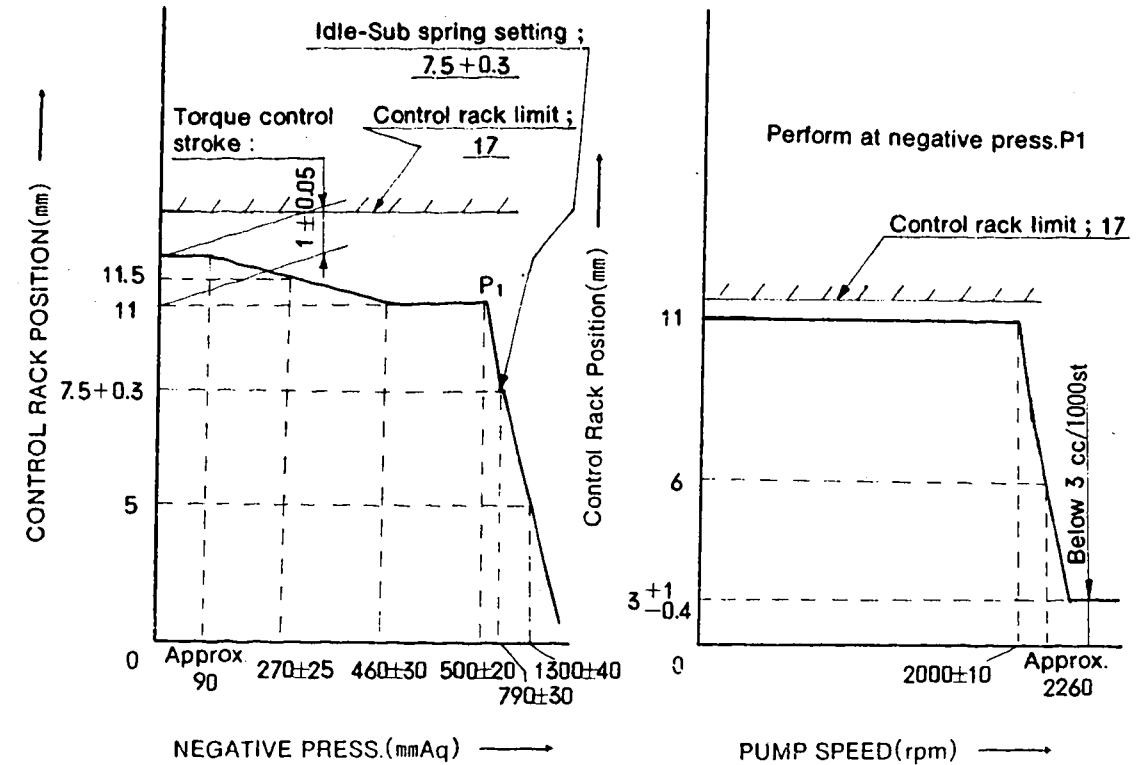

■ Air Tightness Test

1. Increase the pressure of the pneumatic governor's negative pressure chamber to 500 mmAq at a pump speed of 500 rpm and a control rack position of 12 mm.
2. Then, confirm that it takes 10 seconds or more for the negative pressure to fall from 500 mmAq to 480 mmAq.

■ Adjustment

1. Pneumatic Governor (Pump Speed : 500 rpm)

Item	Negative Press. (mmAq)	Rack Position (mm)	Remarks	
Smoke Set Screw Adjustment	0	12	• Adjust using spring capsule ①.	
Torque Control Adjustment	① Start of torque control spring movement	Approx.90	Approx.12	• Adjust thickness of shim ①.
	② End of torque control spring movement	430~490	11	• Adjust thickness of shim ②.
	③ Confirm	245~295	11.5	
	④ Confirm torque control stroke	—	—	• Inspection : 1±0.05 mm

Item	Negative Press. (mmAq)	Rack Position (mm)	Remarks
High-speed control Adjustment	480~520	11	• Adjust thickness of shim ③.
Idling Adjustment	760~820 1260~1340	7.2~7.8 5	• Adjust using spring capsule ②. • Confirm

2. Mechanical Governor (Negative pressure: 480~520 mmAq)

Item	Pump Speed (rpm)	Rack Position (mm)	Remarks
Maximum Speed Control Adjustment	1900~2100	11	• Adjust using screw ①.
	Approx.2260 Approx.2300	6 2.6~4	• Confirm • Confirm (Check the fuel injection quantity: below 3 cc/1000st)

■ Final Adjustment

Smoke Screw Setting			Fuel Injection Quantity Adjustment		
Pump Speed (rpm)	Negative Press. (mmAq)	Injection Q'ty (cc/1000st)	Pump Speed (rpm)	Negative Press. (mmAq)	Injection Q'ty (cc/1000st)
800	0	36.8~37.8	---	---	---
			---	---	---
			---	---	---
			---	---	---
			---	---	---
			---	---	---

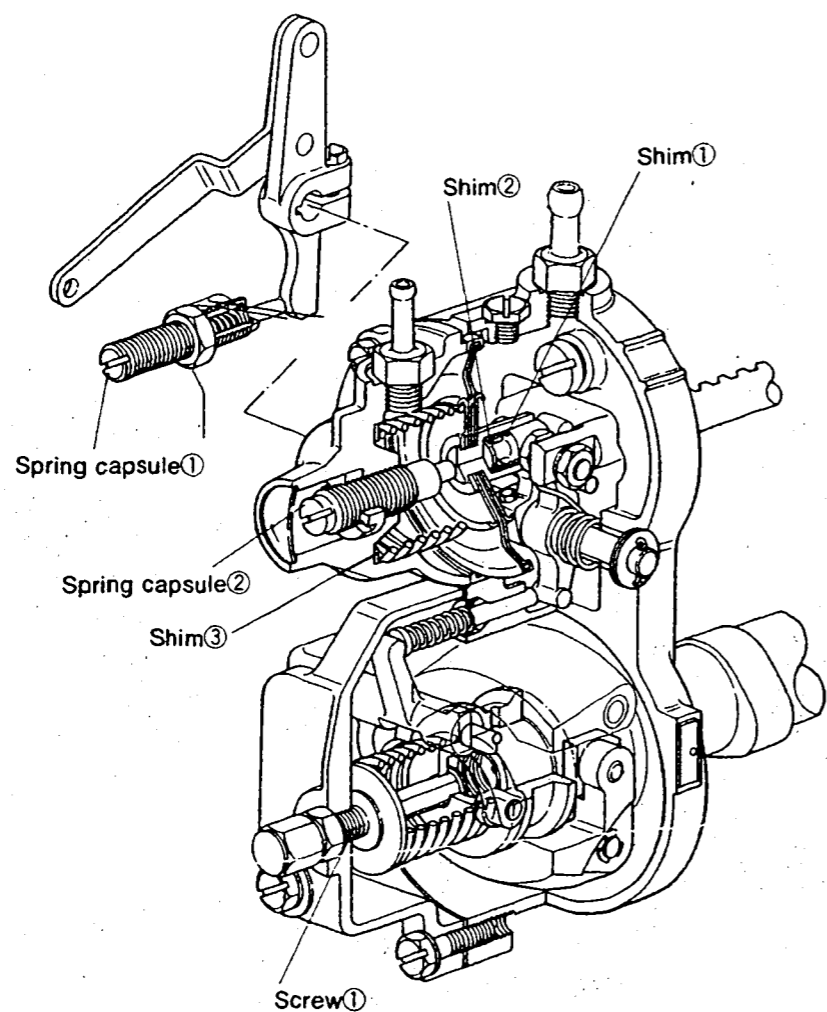

INJ. PUMP CALIBRATION DATA

ENGINE MODEL SD22

BOSCH No.9 400 610 002
 DKKC No. 101431-9900
 Date : 20.Nov.1986 [4]
 Company : NISSAN DIESEL
 No. 16700Y8403

Injection pump : PES4A 101043-8460 Governor : EP/RBD 105542-6871 Timing device : EP/SCD 105622-C240

1. Test Conditions :

Pump rotation : clockwise viewed from drive side
 Nozzle & Nozzle Holder Ass'y : 105780-0000 (BOSCH Type No.DN12SD12) Nozzle Holder : 105780-2080 (BOSCH Type No.EF8511/9A)
 Nozzle opening pressure : 175 Kg/cm² Transfer pump pressure : 1.6 Kg/cm²
 Injection pipe : Inner Dia. 2 mm X Outer Dia. 6 mm - Length 600 mm
 Test Oil : ISO4113 or SAE Standard Test Oil (SAE J967d) Oil Temp. : 40^{±5} °C
 Overflow valve opening pressure : Kg/cm²

2. Injection Timing :

Pre-stroke : No. 1 Plunger 2.3 ±0.05mm
 Note : Adjust with control rod position of mm
 Injection order : 1 ~ 3 ~ 4 ~ 2 (interval : 90° ±30')

Plungers are numbered from the Drive side.

Tappet clearance : Bolt adjustment type ; More than 0.3mm for all cylinders.
 Shim adjustment type ; Manually rotate the camshaft 2~3 times and confirm that it rotates smoothly.

4. Injection Quantity :

Adjusting Point	Rod Position (mm)	Pump Speed (r.p.m)	Injection Q'ty (cc/1000 strokes)	Max. var bet. cyl (%)	Fixed	Remarks
A	11.8	800	34.7 ~ 36.7	±2.5	Rack	Basic
B	10.8	1,700	34.1 ~ 37.3	±4	Rack	
A	11.8	800	34.7 ~ 36.7	-	Lever	Basic
C	6	1,700	(6.2 ~ 7.8)	±7.5	Lever	
D	Approx. 7.7	300	6.4 ~ 8.6	±15	Lever	

5. Timing Advance Specification :

Pump Speed (r.p.m)	500	550	700	900	1,100	1,300	1,500
Advance Angle (deg.)	Below 0.5	Below 0.7	0.5~1.5	1.5~2.5	2.5~3.5	3.5~4.5	Finish 4.5~5.5

3. GOVERNOR ADJUSTMET

101431-9900 2/4

(1) Pneumatic Governor

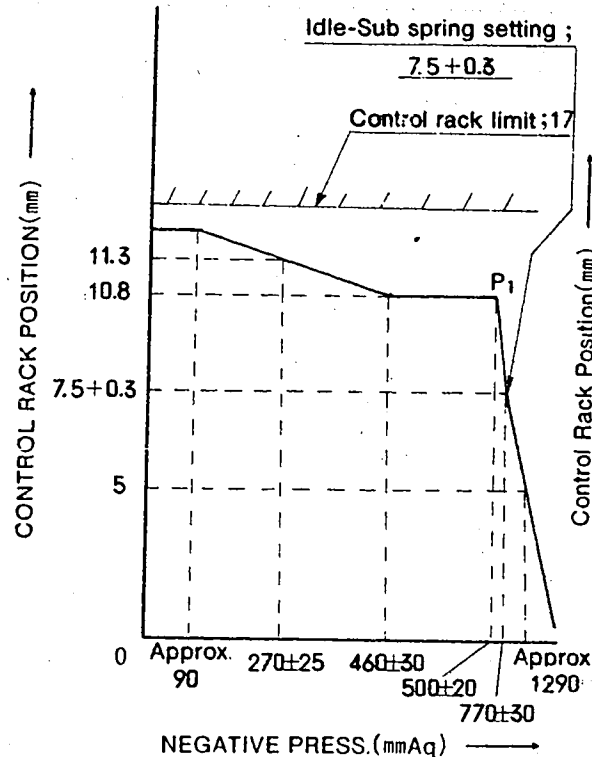

(2) Mechanical Governor

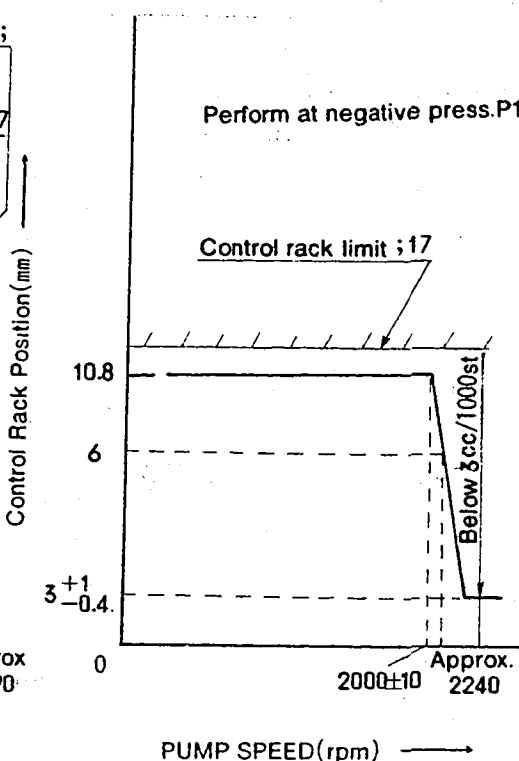

■ Air Tightness Test

1. Increase the pressure of the pneumatic governor's negative pressure chamber to 500 mmAq at a pump speed of 500 rpm and a control rack position of Approx.11.8 mm.
2. Then, confirm that it takes 10 seconds or more for the negative pressure to fall from 500 mmAq to 480 mmAq.

■ Adjustment

1. Pneumatic Governor (Pump Speed : 500 rpm)

Item	Negative Press. (mmAq)	Rack Position (mm)	Remarks
Smoke Set Screw Adjustment	0	Approx.11.8	• Adjust using spring capsule ①.
Torque Control Adjustment	Approx.90	Approx.11.8	• Adjust thickness of shim ①.
	430~490	10.8	• Adjust thickness of shim ②.
	245~295	11.3	
	—	—	• Inspection : 1±0.05 mm

Item	Negative Press. (mmAq)	Rack Position (mm)	Remarks
High-speed control Adjustment	480~520	10.8	• Adjust thickness of shim ③.
Idling Adjustment	740~800 Approx.1290	7.2~7.8 5.0	• Adjust using spring capsule ②. • Confirm

2. Mechanical Governor (Negative pressure: 480~520 mmAq)

Item	Pump Speed (rpm)	Rack Position (mm)	Remarks
Maximum Speed Control Adjustment	1990~2010 Approx.2240 Approx.2300	10.8 6.0 2.6~4	• Adjust using screw ①. • Confirm • Confirm (Check the fuel injection quantity: below 3 cc/1000st)

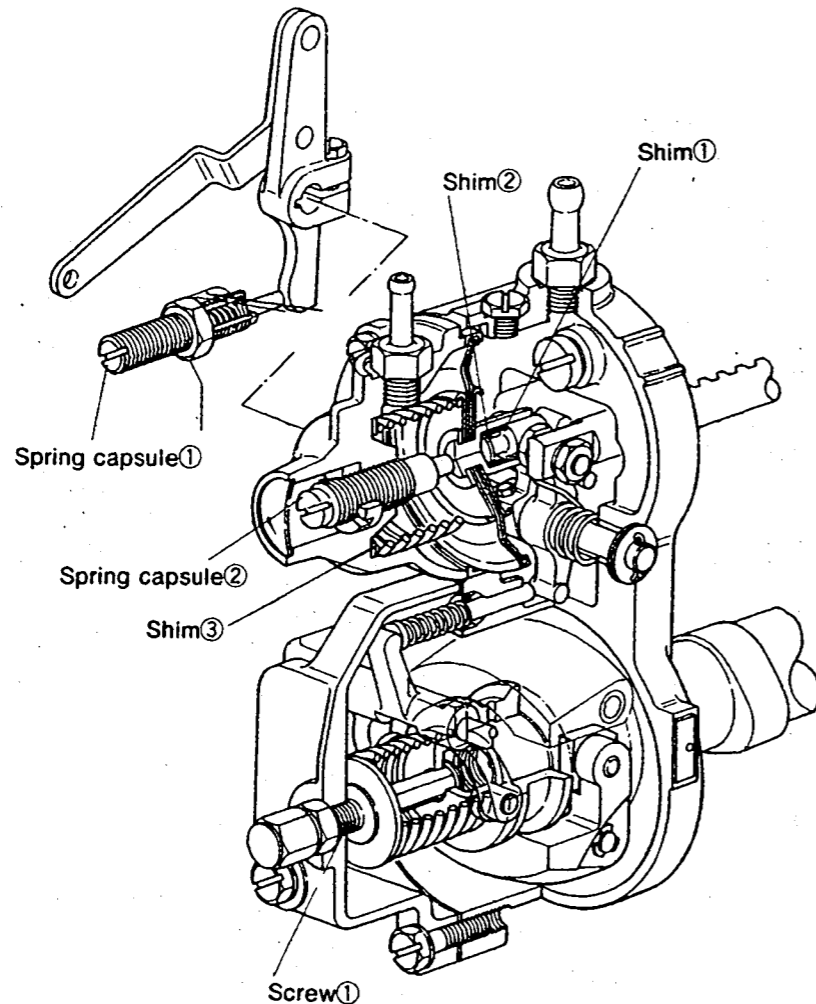

■ Final Adjustment

Smoke Screw Setting			Fuel Injection Quantity Adjustment		
Pump Speed (rpm)	Negative Press. (mmAq)	Injection Q'ty (cc/1000st)	Pump Speed (rpm)	Negative Press. (mmAq)	Injection Q'ty (cc/1000st)
800	0	35.2~36.2	—	—	—
			—	—	—
			—	—	—
			—	—	—
			—	—	—

INJ. PUMP CALIBRATION DATA

ENGINE MODEL SD22

BOSCH No.9 400 610 031

DKKC No. 101433-9230

Date: 20.Nov.1986 ①

Company: NISSAN DIESEL

No. 1670031W02

Injection pump : PES4A
101043-8450

Governor : EP/RBD
105542-6871

Timing device : EP/SCD
105622-0660

1. Test Conditions :

Pump rotation : clockwise viewed from drive side

Nozzle & Nozzle Holder Ass'y : 105780-0000 (BOSCH Type No.DN12SD12)
Nozzle Holder : 105780-2080 (BOSCH Type No.EF8511/9A)
Nozzle opening pressure : 175 Kg/cm²
Transfer pump pressure : 1.6 Kg/cm²

Injection pipe : Inner Dia. 2 mm X Outer Dia. 6 mm - Length 600 mm

Test Oil : ISO4113 or SAE Standard Test Oil (SAE J967d) Oil Temp. : 40⁺⁵ °C

Overflow valve opening pressure : Kg/cm²

2. Injection Timing :

Pre-stroke : No. 1 Plunger 2.3 ±0.05mm

Note : Adjust with control rod position of mm

Injection order : 1 ~ 3 ~ 4 ~ 2 (interval : 90° ±30')

Plungers are numbered from the Drive side.

Tappet clearance : Bolt adjustment type ; More than 0.3mm for all cylinders.
Shim adjustment type ; Manually rotate the camshaft 2~3 times and confirm that it rotates smoothly.

4. Injection Quantity :

Adjusting Point	Rod Position (mm)	Pump Speed (r.p.m)	Injection Q'ty (cc/1000 strokes)	Max. var bet. cyl (%)	Fixed	Remarks
A	12	800	36.0 ~ 38.0	±2.5	Rack	Basic
B	11	1,700	35.4 ~ 38.6	±4	Rack	
C	6	1,700	7.2 ~ 8.8	±7.5	Rack	
D	Approx. 7.7	300	6.4 ~ 8.6	±15	Rack	

5. Timing Advance Specification :

Pump Speed (r.p.m)	500	700	800	1,200	1,800		
Advance Angle (deg.)	Below 0.5	Below 0.9	0.1~1.1	1.5~2.5	Finish 4.5~5.5		

3. GOVERNOR ADJUSTMET

101433-9230 2/4

(1)Pneumatic Governor

(2)Mechanical Governor

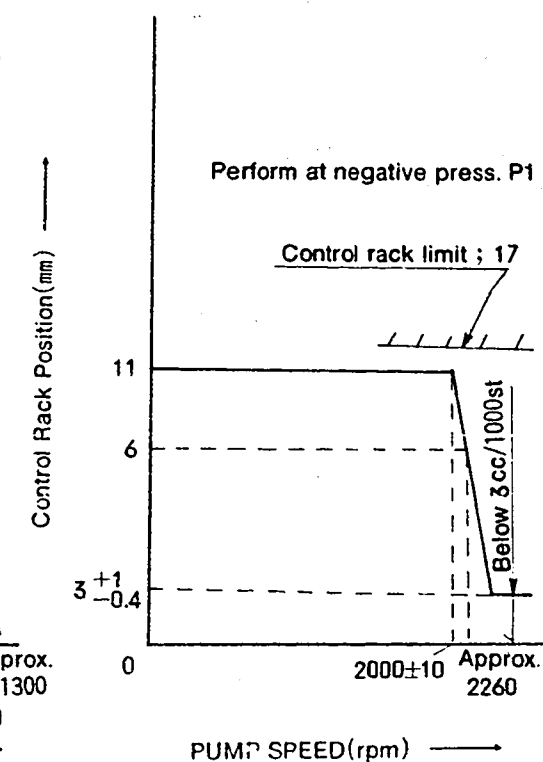
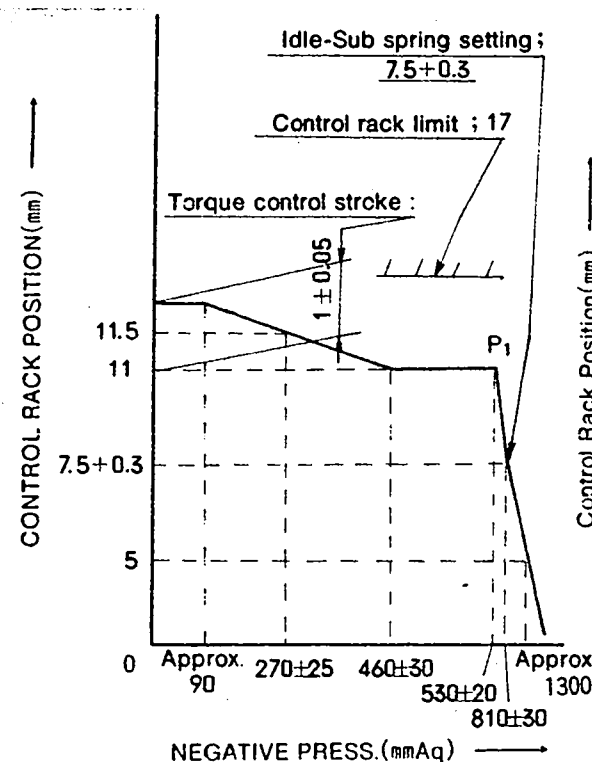

■ Air Tightness Test

1. Increase the pressure of the pneumatic governor's negative pressure chamber to 500 mmAq at a pump speed of 500 rpm and a control rack position of 12 mm.
2. Then, confirm that it takes 10 seconds or more for the negative pressure to fall from 500 mmAq to 480 mmAq.

■ Adjustment

1. Pneumatic Governor (Pump Speed : 500 rpm)

Item	Negative Press. (mmAq)	Rack Position (mm)	Remarks
Smoke Set Screw Adjustment	0	Approx.12	• Adjust using spring capsule ①.
Torque Control Adjustment			
①Start of torque control spring movement	Approx.80	Approx.12	• Adjust thickness of shim ①.
②End of torque control spring movement	430~490	11.0	• Adjust thickness of shim ②.
③Confirm	245~295	11.5	
④Confirm torque control stroke	—	—	• Inspection : 1 ± 0.05 mm

Item	Negative Press. (mmAq)	Rack Position (mm)	Remarks
High-speed control Adjustment	510~550	11	• Adjust thickness of shim ③.
Idling Adjustment	780~840	7.2~7.8	• Adjust using spring capsule ②. • Confirm
	Approx.1300	5	

2. Mechanical Governor (Negative pressure: 510~550 mmAq)

Item	Pump Speed (rpm)	Rack Position (mm)	Remarks
Maximum Speed Control Adjustment	1910~2010	11	• Adjust using screw ①.
	Approx.2260	6	• Confirm
	Approx.2300	2.6~4	• Confirm (Check the fuel injection quantity: below 3 cc/1000st)

■ Final Adjustment

Smoke Screw Setting			Fuel Injection Quantity Adjustment		
Pump Speed (rpm)	Negative Press. (mmAq)	Injection Q'ty (cc/1000st)	Pump Speed (rpm)	Negative Press. (mmAq)	Injection Q'ty (cc/1000st)
800	0	36.5~37.5	---	---	---
			---	---	---
			---	---	---
			---	---	---
			---	---	---
			---	---	---

■ Timing Setting

At No.1 plunger's beginning of injection position.

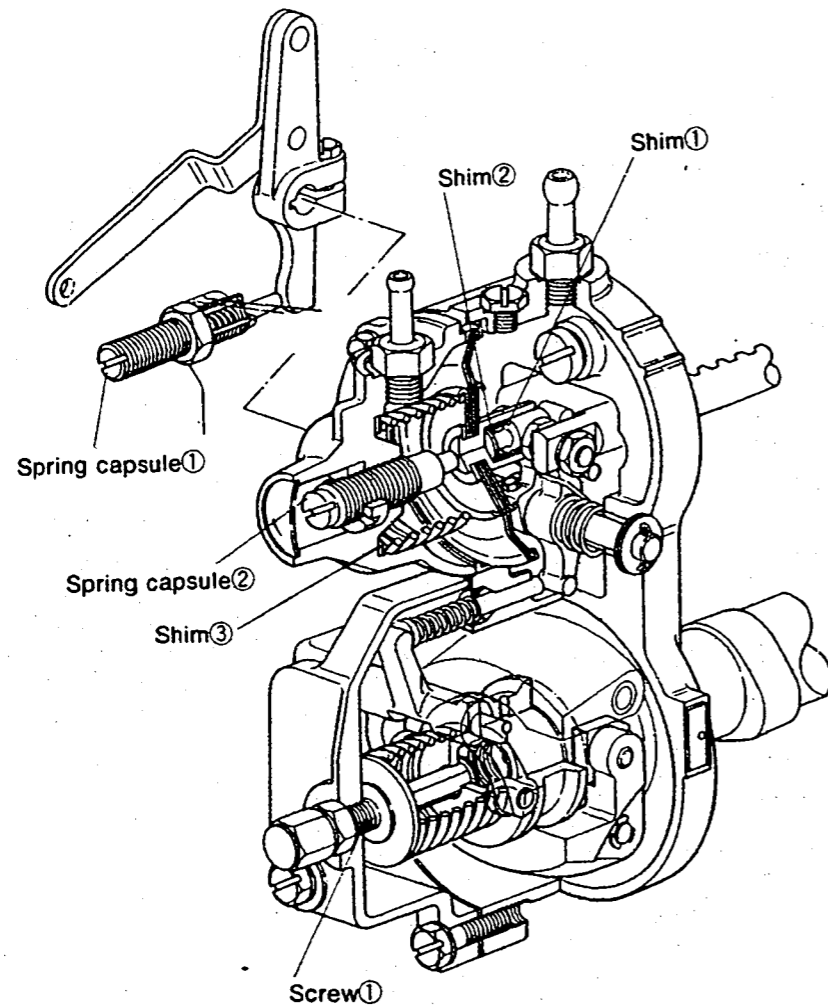

Pump center line

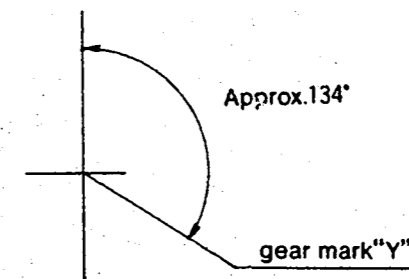

INJ. PUMP CALIBRATION DATA

ENGINE MODEL SD22

BOSCH No.9 400 610 032
 DKKC No. 101433-9260
 Date : 20.Nov.1986
 Company : NISSAN DIESEL
 No. 1670033W00

Injection pump : PES4A 101043-8450 Governor : EP/RBD 105542-6871 Timing device : EP/SCD 105622-0660

1. Test Conditions :

Pump rotation : clockwise viewed from drive side

Nozzle & Nozzle Holder Ass'y : 105780-0000 (BOSCH Type No.DN12SD12) Nozzle Holder : 105780-2080 (BOSCH Type No.EF8511/9A)

Nozzle opening pressure : 175 Kg/cm² Transfer pump pressure : 1.6 Kg/cm²

Injection pipe : Inner Dia. 2 mm X Outer Dia. 6 mm - Length 600 mm

Test Oil : ISO4113 or SAE Standard Test Oil (SAE J967d) Oil Temp. : 40^{±5} °C

Overflow valve opening pressure : Kg/cm²

2. Injection Timing :

Pre-stroke : No. 1 Plunger 2.3 ±0.05mm
 Note : Adjust with control rod position of mm

Injection order : 1 ~ 3 ~ 4 ~ 2 (interval : 90° ±30')

Plungers are numbered from the Drive side.

Tappet clearance : Bolt adjustment type ; More than 0.3mm for all cylinders.
 Shim adjustment type ; Manually rotate the camshaft 2~3 times and confirm that it rotates smoothly.

4. Injection Quantity :

Adjusting Point	Rod Position (mm)	Pump Speed (r.p.m)	Injection Q'ty (cc/1000 strokes)	Max. var bet. cyl (%)	Fixed	Remarks
A	11	1,000	30.7 ~ 32.7	±2.5	Rack	Basic
B	10	1,700	29.7 ~ 32.9	±4	Rack	
C	6	1,700	7.2 ~ 8.8	±7.5	Rack	
D	7.7	300	6.4 ~ 8.6	±15	Rack	

5. Timing Advance Specification :

Pump Speed (r.p.m)	500	700	800	1,200	1,800		
Advance Angle (deg.)	Below 0.5	Below 0.9	0.1~1.1	1.5~2.5	Finish 4.5~5.5		

3. GOVERNOR ADJUSTMET

101433-9260 2/4

(1)Pneumatic Governor

(2)Mechanical Governor

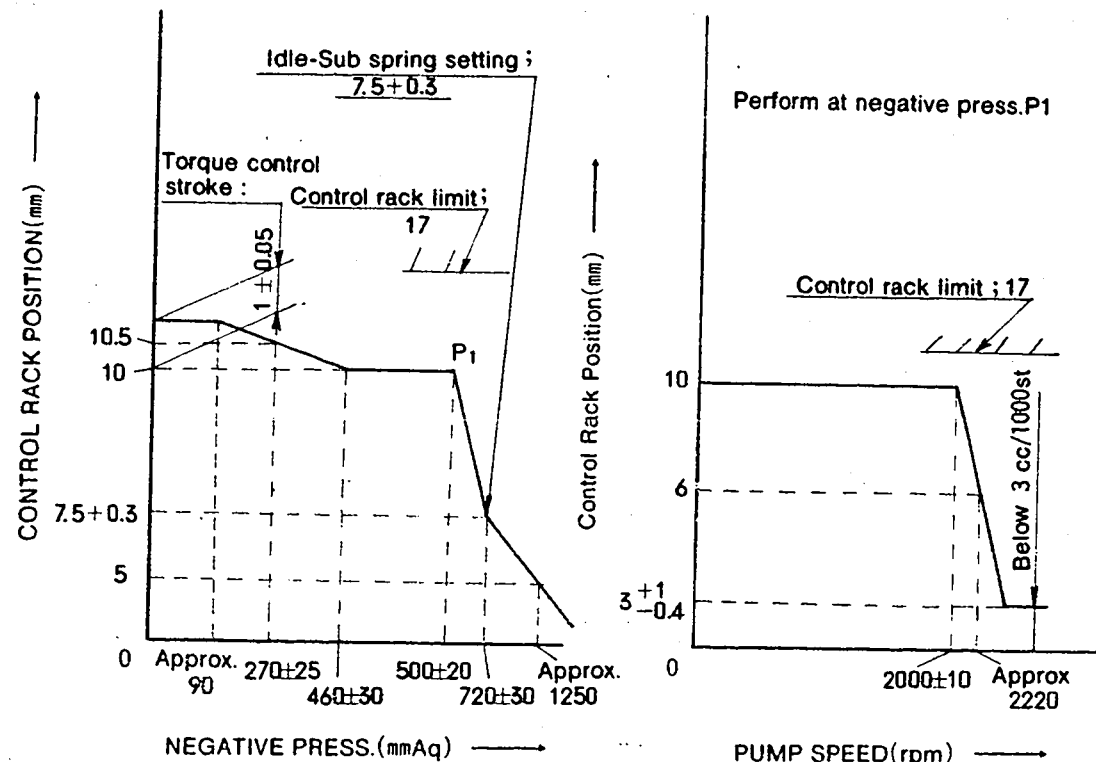

■ Air Tightness Test

1. Increase the pressure of the pneumatic governor's negative pressure chamber to 500 mmAq at a pump speed of 500 rpm and a control rack position of 11 mm.
2. Then, confirm that it takes 10 seconds or more for the negative pressure to fall from 500 mmAq to 480 mmAq.

■ Adjustment

1. Pneumatic Governor (Pump Speed : 500 rpm)

Item	Negative Press. (mmAq)	Rack Position (mm)	Remarks
Smoke Set Screw Adjustment	0	Approx.11	• Adjust using spring capsule ①.
Torque Control Adjustment			
①Start of torque control spring movement	Approx.90	Approx.11	• Adjust thickness of shim ①.
②End of torque control spring movement	430~490	10	• Adjust thickness of shim ②.
③Confirm	245~295	10.5	
④Confirm torque control stroke	—	—	• Inspection : 1±0.05 mm

Item	Negative Press. (mmAq)	Rack Position (mm)	Remarks
High-speed control Adjustment	480~520	10	• Adjust thickness of shim ③.
Idling Adjustment	690~750 Approx.1250	7.2~7.8 5	• Adjust using spring capsule ②. • Confirm

2. Mechanical Governor (Negative pressure: 480~520 mmAq)

Item	Pump Speed (rpm)	Rack Position (mm)	Remarks
Maximum Speed Control Adjustment	1990~2010	10	• Adjust using screw ①.
	Approx.2220	6	• Confirm
	Approx.2300	2.6~4	• Confirm (Check the fuel injection quantity: below 3 cc/1000st)

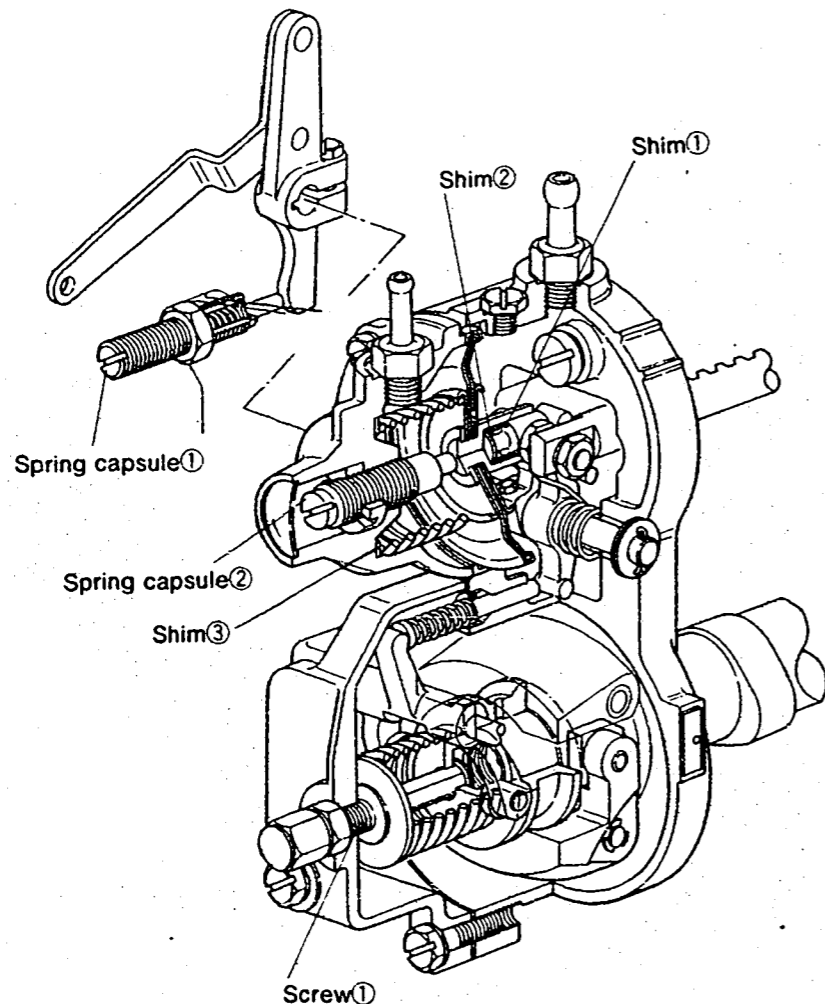

■ Final Adjustment

Smoke Screw Setting			Fuel Injection Quantity Adjustment		
Pump Speed (rpm)	Negative Press. (mmAq)	Injection Q'ty (cc/1000st)	Pump Speed (rpm)	Negative Press. (mmAq)	Injection Q'ty (cc/1000st)
1000	0	31.2~32.2	—	—	—
			—	—	—
			—	—	—
			—	—	—
			—	—	—
			—	—	—

■ Timing Setting

At No.1 plunger's beginning of injection position.
B.T.D.C.:

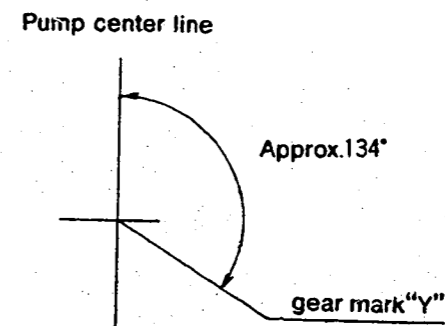

INJ. PUMP CALIBRATION DATA

ENGINE MODEL SD25

BOSCH No. 9 400 610 007
 DKKC No. 101433-9390
 Date: 20.Nov.1986 [4]
 Company: NISSAN DIESEL
 No. 16700L2000

Injection pump : PES4A Governor : EP/MZ Timing device : EP/SCD
 101043-8490 105520-3150 105622-0850

1. Test Conditions :

Pump rotation : clockwise viewed from drive side

Nozzle & Nozzle Holder Ass'y : 105780-0000 (BOSCH Type No. DN12SD12)
 Nozzle Holder : 105780-2080 (BOSCH Type No. EF8511/9A)
 Nozzle opening pressure : 175 Kg/cm² Transfer pump pressure : 1.6 Kg/cm²

Injection pipe : Inner Dia. 2 mm X Outer Dia. 6 mm - Length 600 mm

Test Oil : ISO4113 or SAE Standard Test Oil (SAE J967d) Oil Temp. : 40^{±5} °C

Overflow valve opening pressure : Kg/cm²

2. Injection Timing :

Pre-stroke : No. 1 Plunger 2.3 ±0.05mm
 Note : Adjust with control rod position of mm

Injection order : 1 ~ 3 ~ 4 ~ 2 (interval : 90 ° ± 30')
 Plungers are numbered from the Drive side.

Tappet clearance : Bolt adjustment type ; More than 0.3mm for all cylinders.
 Shim adjustment type ; Manually rotate the camshaft 2~3 times and confirm that it rotates smoothly.

4. Injection Quantity :

Adjusting Point	Rod Position (mm)	Pump Speed (r.p.m)	Injection Q'ty (cc/1000 strokes)	Max. var bet. cyl (%)	Fixed	Remarks
	14.8	700	34.2 ~ 36.2	±2.5	Rack	Basic
	Approx. 10.6	300	6.4 ~ 8.6	±15	Rack	

5. Timing Advance Specification :

Pump Speed (r.p.m)	500	700	900	1,150		
Advance Angle (deg.)	Below 0.5	0.3~1.3	1.1~2.1	2.4~3.4	Finish (5)°	

3. GOVERNOR ADJUSTMET

101433-9390 2/4

Pneumatic Governor

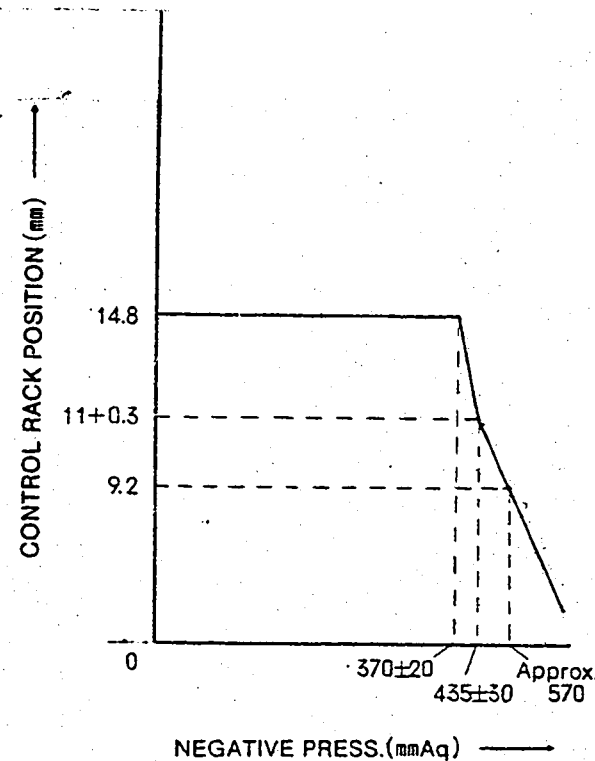

■ Air Tightness Test

1. Increase the pressure of the pneumatic governor's negative pressure chamber to 300 mmAq at a pump speed of 500 rpm and a control rack position of 14.8 mm.
2. Then, confirm that it takes 10 seconds or more for the negative pressure to fall from 500 mmAq to 480 mmAq.

■ Adjustment

1. Pneumatic Governor (Pump Speed : 500 rpm)

Item	Negative Press. (mmAq)	Rack Position (mm)	Remarks
Smoke Set Screw Adjustment	0	14.8	• Adjust using spring capsule ①.
Torque Control Adjustment			
① Start of torque control spring movement	—	—	• Adjust thickness of shim ①.
② End of torque control spring movement	—	—	• Adjust thickness of shim ②.
③ Confirm	—	—	
④ Confirm torque control stroke	—	—	• Inspection : — mm

Item	Negative Press. (mmAq)	Rack Position (mm)	Remarks
High-speed control Adjustment	350~390	14.8	• Adjust thickness of shim ③.
Idling Adjustment	405~465	10.7~11.3	• Adjust using spring capsule ②. • Confirm
	530~610	9.2	

■ Timing Setting

At No.1 plunger's beginning of injection position.

B.T.D.C.: —

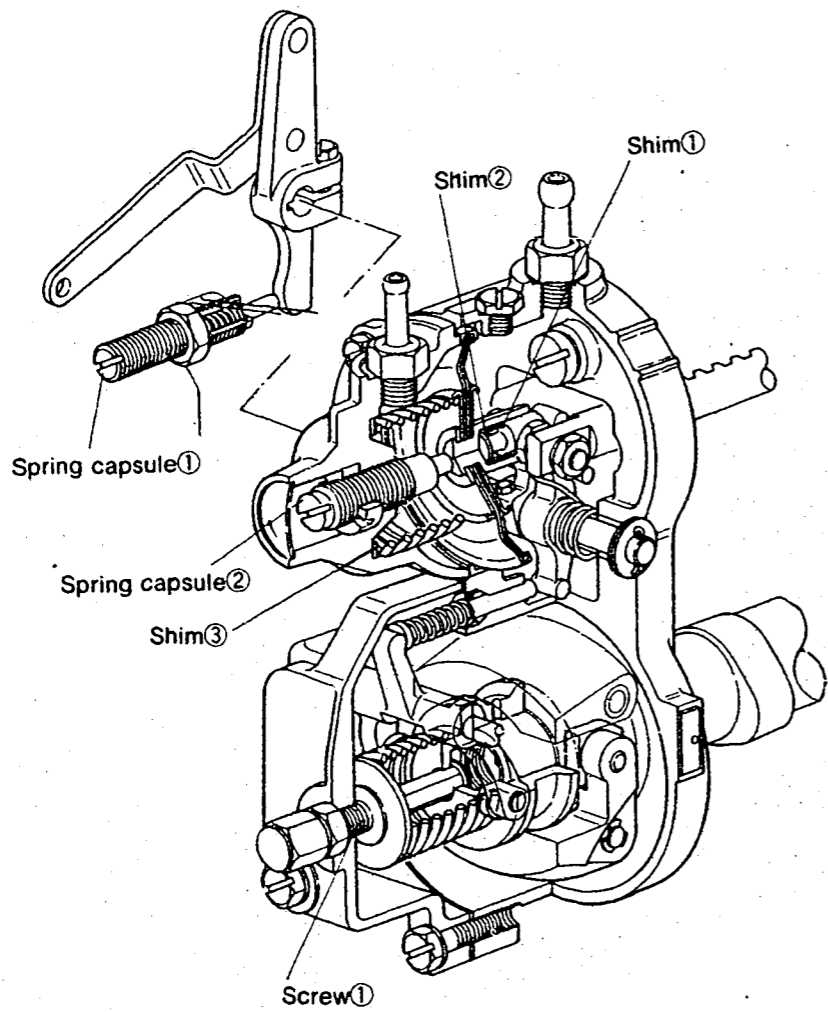

Pump center line

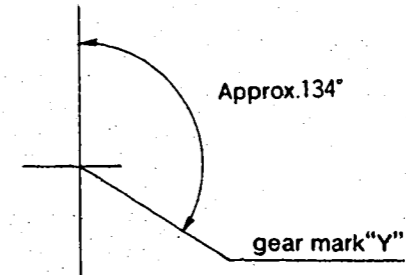

INJ. PUMP CALIBRATION DATA

ENGINE MODEL SD22

BOSCH No.9 400 610 033
 DKKC No. 101433-9401
 Date: 20.Nov.1986
 Company: NISSAN DIESEL
 No. 1670034W00

Injection pump : PES4A 101043-8640 Governor : EP/RBD 105542-6871 Timing device : EP/SCD 105622-0770

1. Test Conditions :

Pump rotation : clockwiseviewed from drive side

Nozzle & Nozzle Holder Ass'y : 105780-0000 (BOSCH Type No.DN12SD12) Nozzle Holder : 105780-2080 (BOSCH Type No.F58511/9A)

Nozzle opening pressure : 175 Kg/cm² Transfer pump pressure : 1.6 Kg/cm²

Injection pipe : Inner Dia. 2 mm X Outer Dia. 6 mm - Length 600 mm

Test Oil : ISO4113 or SAE Standard Test Oil (SAE J967d) Oil Temp. : 40⁺5 °C

Overflow valve opening pressure : Kg/cm²

2. Injection Timing :

Pre-stroke : No. 1 Plunger 2.3 ±0.05mm
 Note : Adjust with control rod position of mm

Injection order : 1 ~ 3 ~ 4 ~ 2 (interval : 90° ±30')

Plungers are numbered from the Drive side.

Tappet clearance : Bolt adjustment type ; More than 0.3mm for all cylinders.
 Shim adjustment type ; Manually rotate the camshaft 2~3 times and confirm that it rotates smoothly.

4. Injection Quantity :

Adjusting Point	Rod Position (mm)	Pump Speed (r.p.m)	Injection Q'ty (cc/1000 strokes)	Max. var bet. cyl (%)	Fixed	Remarks
	12	800	35.7 ~ 37.7	±2.4	Rack	Basic
	Approx. 7.5	300	6.4 ~ 8.6	±15	Rack	
A	12	800	35.7 ~ 37.7	-	Lever	Basic

5. Timing Advance Specification :

Pump Speed (r.p.m)	500	700	800	1,200	1,800		
Advance Angle (deg.)	Below 0.5	Below 0.9	0.1~1.1	1.5~2.5	Finish 4.5~5.5		

3. GOVERNOR ADJUSTMET

101433-9401 2/4

(1)Pneumatic Governor

(2)Mechanical Governor

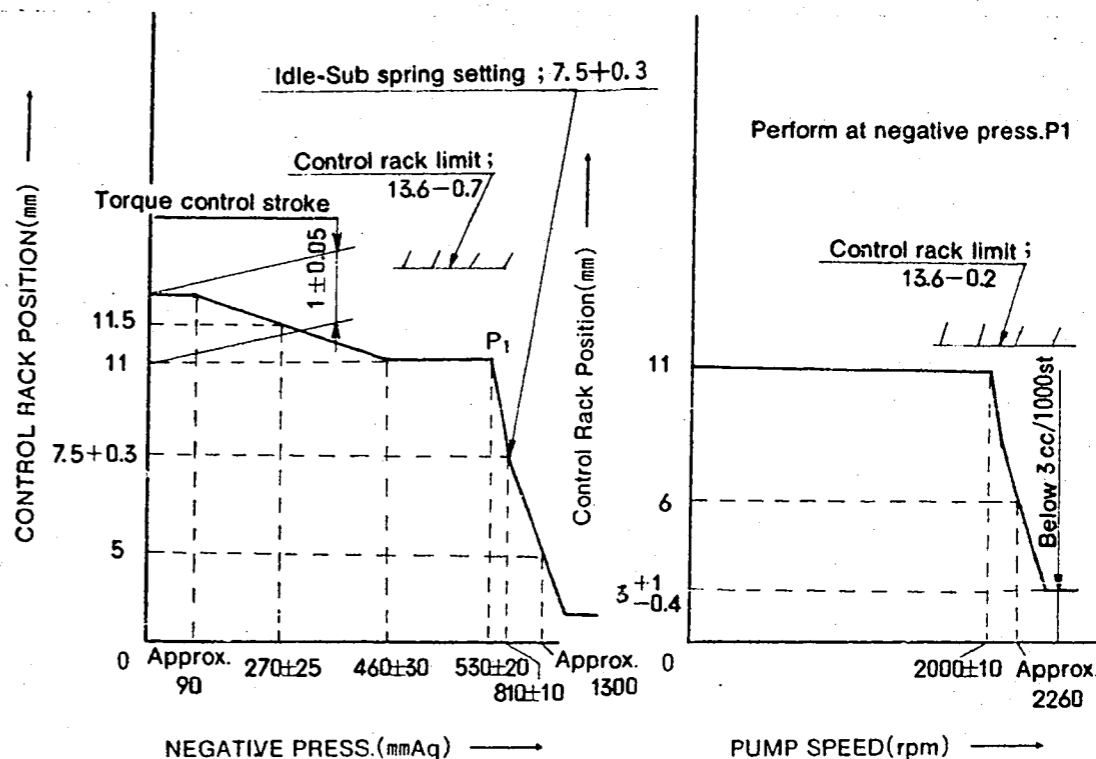

■ Air Tightness Test

- Increase the pressure of the pneumatic governor's negative pressure chamber to 500 mmAq at a pump speed of 500 rpm and a control rack position of 12 mm.
- Then, confirm that it takes 10 seconds or more for the negative pressure to fall from 500 mmAq to 480 mmAq.

■ Adjustment

- Pneumatic Governor (Pump Speed : 500 rpm)

Item	Negative Press. (mmAq)	Rack Position (mm)	Remarks
Smoke Set Screw Adjust-ment	0	Approx.12	• Adjust using spring capsule ①.
Torque Control Adjustment			
①Start of torque control spring movement	Approx.90	Approx.12	• Adjust thickness of shim ①.
②End of torque control spring movement	430~490	11	• Adjust thickness of shim ②.
③Confirm	245~295	11.5	
④Confirm torque control stroke	—	—	• Inspection : 1±0.05 mm

Item	Negative Press. (mmAq)	Rack Position (mm)	Remarks
High-speed control Adjustment	510~550	11	• Adjust thickness of shim ③.
Idling Adjustment	780~840 Approx.1300	7.2~7.8 5	• Adjust using spring capsule ②. • Confirm

2. Mechanical Governor (Negative pressure: 510~550 mmAq)

Item	Pump Speed (rpm)	Rack Position (mm)	Remarks
Maximum Speed Control Adjustment	1990~2010 Approx.2260 Approx.2300	11 6 2.6~4	• Adjust using screw ①. • Confirm • Confirm (Check the fuel injection quantity:below 3 cc/1000st)

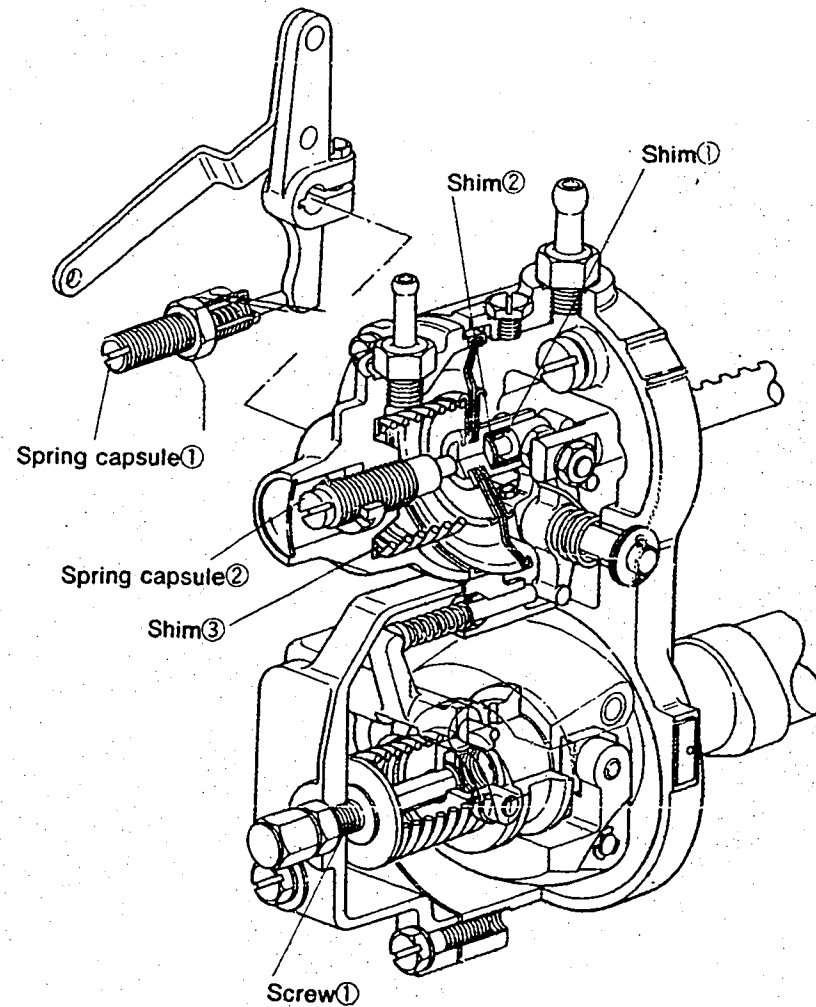

Final Adjustment

Smoke Screw Setting			Fuel Injection Quantity Adjustment		
Pump Speed (rpm)	Negative Press. (mmAq)	Injection Q'ty (cc/1000st)	Pump Speed (rpm)	Negative Press. (mmAq)	Injection Q'ty (cc/1000st)
800	0	36.2~37.2	—	—	—
			—	—	—
			—	—	—
			—	—	—
			—	—	—

Timing Setting

At No.1 plunger's beginning of injection position.

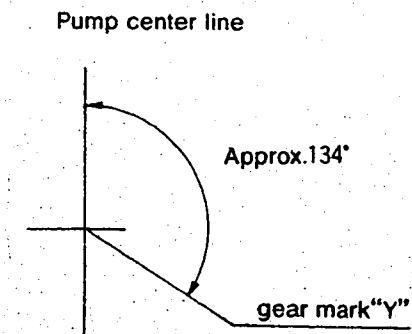

INJ. PUMP CALIBRATION DATA

ENGINE MODEL SD22

BOSCH No. 9 400 610 034
 DKKC No. 101433-9421
 Date: 20.Nov.1986 2
 Company: NISSAN DIESEL
 No. 1670034W02

Injection pump : PES4A Governor : EP/RBD Timing device : EP/SCD
 101043-8640 105542-6871 105622-0770

1. Test Conditions :

Pump rotation : clockwise viewed from drive side

Nozzle & Nozzle Holder Ass'y : 105780-0000 Nozzle Holder : 105780-2080
 (BOSCH Type No.DN12SD12) (BOSCH Type No.EF8511/9A)

Nozzle opening pressure : 175 Kg/cm² Transfer pump pressure : 1.6 Kg/cm²

Injection pipe : Inner Dia. 2 mm X Outer Dia. 6 mm - Length 600 mm

Test Oil : ISO4113 or SAE Standard Test Oil (SAE J967d) Oil Temp. : 40^{±5} °C

Overflow valve opening pressure : Kg/cm²

2. Injection Timing :

Pre-stroke : No. 1 Plunger 2.3 ±0.05mm
 Note : Adjust with control rod position of mm

Injection order : 1 ~ 3 ~ 4 ~ 2 (Interval : 90 ° ± 30')

Plungers are numbered from the Drive side.

Tappet clearance : Bolt adjustment type ; More than 0.3mm for all cylinders.
 ; Shim adjustment type ; Manually rotate the camshaft 2~3 times and confirm that it rotates smoothly.

4. Injection Quantity :

Adjusting Point	Rod Position (mm)	Pump Speed (r.p.m)	Injection Q'ty (cc/1000 strokes)	Max. var bet. cyl (%)	Fixed	Remarks
A	11.6	800	31.6 ~ 33.6	±2.5	Rack	Basic
B	Approx. 7.9	300	6.4 ~ 8.6	±15	Rack	
A	11.6	800	31.6 ~ 33.6	-	Lever	Basic

5. Timing Advance Specification :

Pump Speed (r.p.m)	500	700	800	1,200	1,800		
Advance Angle (deg.)	Below 0.5	Below 0.9	0.1~1.1	1.5~2.5	Finish 4.5~5.5		

3. GOVERNOR ADJUSTMET

101433-9421 2/4

(1) Pneumatic Governor

(2) Mechanical Governor

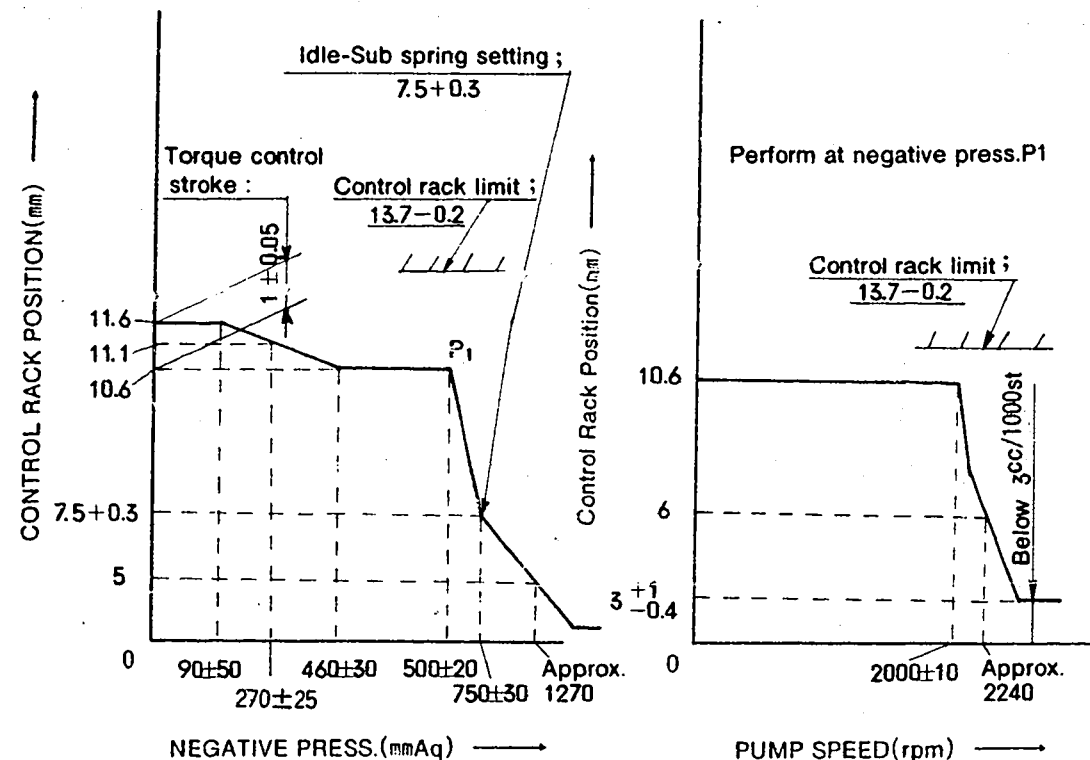

■ Air Tightness Test

- Increase the pressure of the pneumatic governor's negative pressure chamber to 500 mmAq at a pump speed of 500 rpm and a control rack position of 11.6 mm.
- Then, confirm that it takes 10 seconds or more for the negative pressure to fall from 500 mmAq to 480 mmAq.

■ Adjustment

- Pneumatic Governor (Pump Speed : 500 rpm)

Item	Negative Press. (mmAq)	Rack Position (mm)	Remarks
Smoke Set Screw Adjustment	0	11.6	• Adjust using spring capsule ①.
Torque Control Adjustment			
① Start of torque control spring movement	40~140	11.6	• Adjust thickness of shim ①.
② End of torque control spring movement	430~490	10.6	• Adjust thickness of shim ②.
③ Confirm	245~295	11.1	
④ Confirm torque control stroke	—	—	• Inspection : 1 ± 0.05 mm



DIESEL KIKI CO., LTD. 3-6-7 SHIBUYA, SHIBUYA-KU, TOKYO 150, JAPAN
 Service Department Tel. (03) 400-1551 Fax: (03) 499-4115

Item	Negative Press. (mmAq)	Rack Position (mm)	Remarks
High-speed control Adjustment	480~520	10.6	• Adjust thickness of shim ③.
Idling Adjustment	720~780 Approx.1270	7.2~7.8 5.0	• Adjust using spring capsule ②. • Confirm

2. Mechanical Governor (Negative pressure: 480~520 mmAq)

Item	Pump Speed (rpm)	Rack Position (mm)	Remarks
Maximum Speed Control Adjustment	1990~2010 Approx.2240 Approx.2300	10.6 6.0 2.6~4	• Adjust using screw ①. • Confirm • Confirm (Check the fuel injection quantity: below 3 cc/1000st)

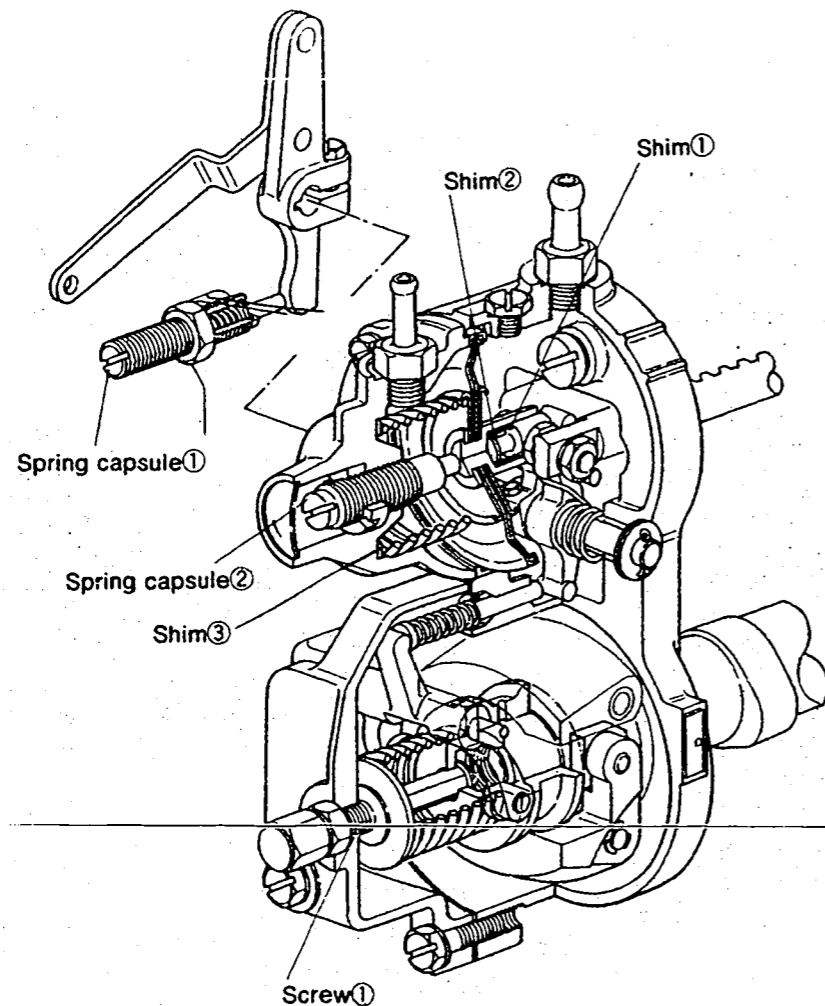

■ Final Adjustment

Smoke Screw Setting			Fuel Injection Quantity Adjustment		
Pump Speed (rpm)	Negative Press. (mmAq)	Injection Q'ty (cc/1000st)	Pump Speed (rpm)	Negative Press. (mmAq)	Injection Q'ty (cc/1000st)
800	0	31.1~33.1	—	—	—
			—	—	—
			—	—	—
			—	—	—
			—	—	—
			—	—	—

■ Timing Setting

At No.1 plunger's beginning of injection position.

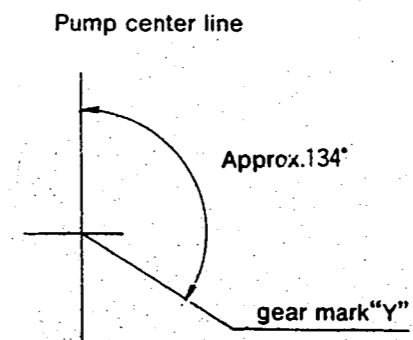

INJ. PUMP CALIBRATION DATA

ENGINE MODEL SD25

BOSCH No.9 400 610 035
 DKKC No. 101441-9040
 Date: 20.Nov.1986 1
 Company: NISSAN DIESEL
 No. 16700T8263

Injection pump : PES4A 101044-8100 Governor : EP/RBD 105542-3690 Timing device : EP/SCD 105622-1000

1. Test Conditions :

Pump rotation : clockwise viewed from drive side

Nozzle & Nozzle Holder Ass'y : 105780-0000 (BOSCH Type No.DN12SD12) Nozzle Holder : 105780-2080 (BOSCH Type No.EF8511/9A)

Nozzle opening pressure : 175 Kg/cm² Transfer pump pressure : 1.6 Kg/cm²

Injection pipe : Inner Dia. 2 mm X Outer Dia. 6 mm - Length 600 mm

Test Oil : ISO4113 or SAE Standard Test Oil (SAE J967d) Oil Temp. : 40⁺⁵ °C

Overflow valve opening pressure : Kg/cm²

2. Injection Timing :

Pre-stroke : No. 1 Plunger 2.15 ±0.05mm
 Note : Adjust with control rod position of mm

Injection order : 1 ~ 3 ~ 4 ~ 2 (interval : 90° ±30')

Plungers are numbered from the Drive side.

Tappet clearance : Bolt adjustment type : More than 0.3mm for all cylinders.
 : Shim adjustment type : Manually rotate the camshaft 2~3 times and confirm that it rotates smoothly.

4. Injection Quantity :

Adjusting Point	Rod Position (mm)	Pump Speed (r.p.m)	Injection Q'ty (cc/1000 strokes)	Max. var bet. cyl (%)	Fixed	Remarks
	11.7	1,000	35.6 ~ 37.6	±2.5	Rack	Basic
	Approx. 8.2	300	6.9 ~ 9.1	±15	Rack	
	11.7	1,000	35.6 ~ 37.6	-	Lever	Basic

5. Timing Advance Specification :

Pump Speed (r.p.m)	500	800	1,200	1,800	2,000		
Advance Angle (deg.)	Below 0.5	5.5~6.5	1.5~2.5	4.5~5.5	Finish 5.5~6.5		

3. GOVERNOR ADJUSTMET

101441-9040 2/4

(1) Pneumatic Governor

(2) Mechanical Governor

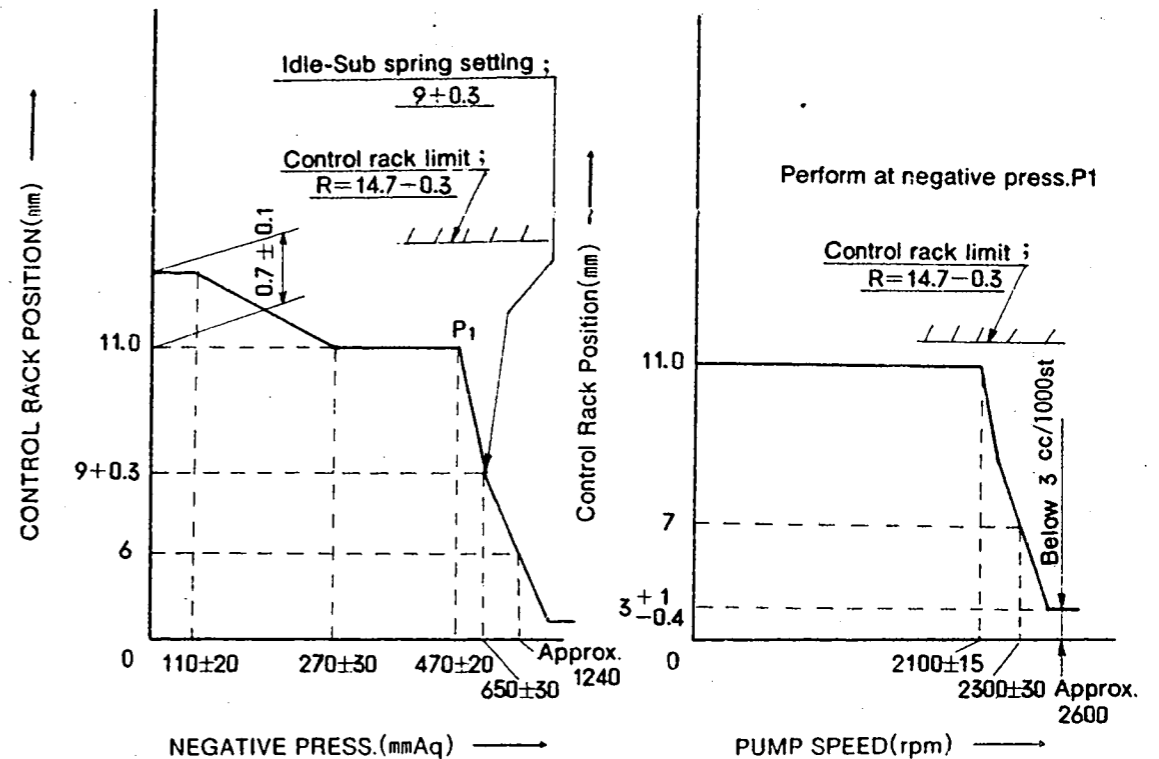

■ Air Tightness Test

1. Increase the pressure of the pneumatic governor's negative pressure chamber to 500 mmAq at a pump speed of 500 rpm and a control rack position of Approx. 11.7 mm.
2. Then, confirm that it takes 10 seconds or more for the negative pressure to fall from 500 mmAq to 480 mmAq.

■ Adjustment

1. Pneumatic Governor (Pump Speed : 500 rpm)

Item	Negative Press. (mmAq)	Rack Position (mm)	Remarks
Smoke Set Screw Adjustment	0	Approx. 11.7	• Adjust using spring capsule ①.
Torque Control Adjustment			
① Start of torque control spring movement	180~130	Approx. 11.7	• Adjust thickness of shim ①.
② End of torque control spring movement	240~300	11.0	• Adjust thickness of shim ②.
③ Confirm	—	—	
④ Confirm torque control stroke	—	—	• Inspection : 0.7 ± 0.1 mm



DIESEL KIKI CO., LTD.
 Service Department

3-6-7 SHIBUYA, SHIBUYA-KU, TOKYO 150, JAPAN
 Tel. (03) 400-1551 Fax: (03) 499-4 15

Item	Negative Press. (mmAq)	Rack Position (mm)	Remarks
High-speed control Adjustment	450~490	11.0	• Adjust thickness of shim ③.
Idling Adjustment	620~680 Approx. 1240	9~9.3 6	• Adjust using spring capsule ②. • Confirm

2. Mechanical Governor (Negative pressure: 470±20 mmAq)

Item	Pump Speed (rpm)	Rack Position (mm)	Remarks
Maximum Speed Control Adjustment	2090~2110	11.0	• Adjust using screw ①.
	2270~2330	7	• Confirm
	Approx. 2600	2.6~4	• Confirm (Check the fuel injection quantity: below 3 cc/1000st)

■ Final Adjustment

Smoke Screw Setting			Fuel Injection Quantity Adjustment		
Pump Speed (rpm)	Negative Press. (mmAq)	Injection Q'ty (cc/1000st)	Pump Speed (rpm)	Negative Press. (mmAq)	Injection Q'ty (cc/1000st)
1000	0	36.1~37.1	—	—	—
			—	—	—
			—	—	—
			—	—	—
			—	—	—

■ Timing Setting

At No.1 plunger's beginning of injection position.

B.T.D.C.: 18°

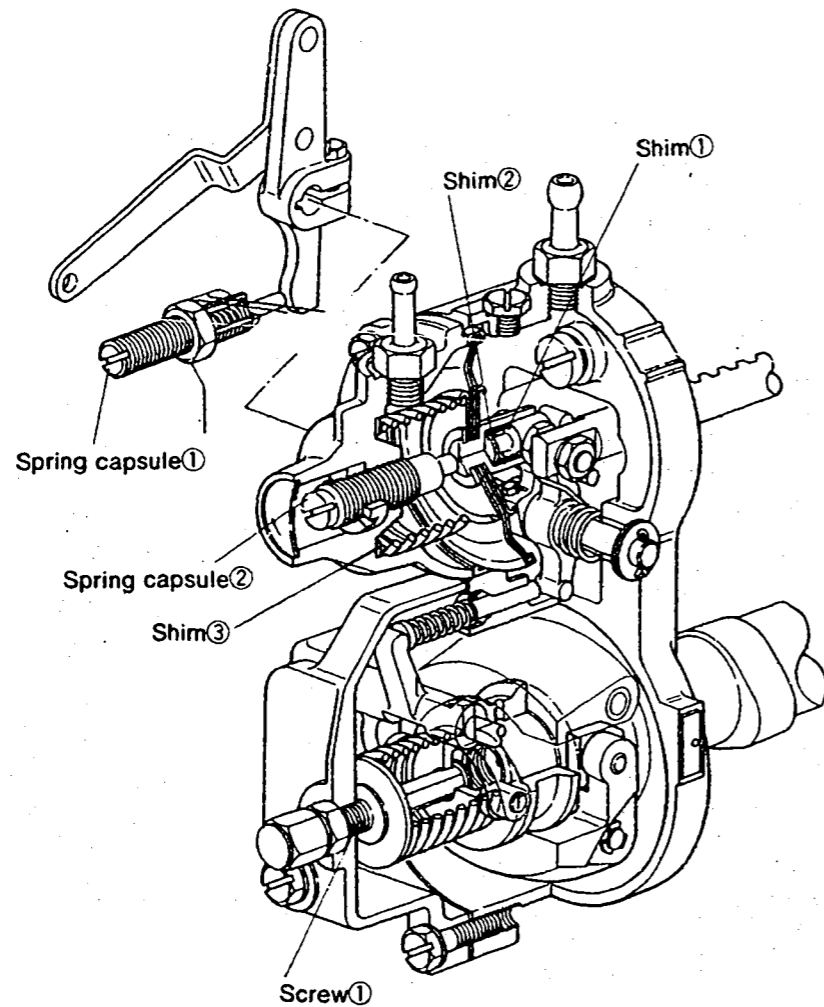

Pump center line

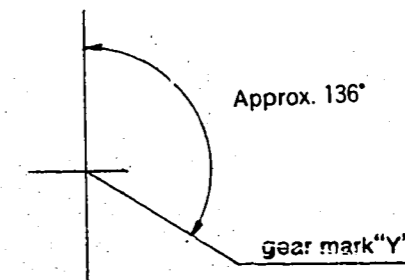

INJ. PUMP CALIBRATION DATA

ENGINE MODEL SD25

BOSCH No.9 400 610 009
 DKKC No. 101441-9121
 Date : 20.Nov.1986 [2]
 Company : NISSAN DIESEL
 No. 1670054W60

Injection pump : PES4A Governor : EP/RBD Timing device : EP/SCD
 101044-8100 105542-3840 105622-1230

1. Test Conditions :

Pump rotation : clockwiseviewed from drive side

Nozzle & Nozzle Holder Ass'y : 105780-0000 Nozzle Holder : 105780-2080
 (BOSCH Type No.DN12SD12) (BOSCH Type No.EF8511/9A)

Nozzle opening pressure : 175 Kg/cm² Transfer pump pressure : 1.6 Kg/cm²

Injection pipe :
 Inner Dia. 2 mm X Outer Dia. 6 mm - Length 600 mm

Test Oil : ISO4113 or SAE Standard Test Oil (SAE J967d) Oil Temp. : 40^{±5} °C

Overflow valve opening pressure : Kg/cm²

2. Injection Timing :

Pre-stroke : No. 1 Plunger 2.15 ±0.05mm
 Note : Adjust with control rod position of mm

Injection order : 1 ~ 3 ~ 4 ~ 2 (interval : 90 °±30')

Plungers are numbered from the Drive side.

Tappet clearance : Bolt adjustment type ; More than 0.3mm for all cylinders.
 ; Shim adjustment type ; Manually rotate the camshaft 2~3 times and confirm that it rotates smoothly.

4. Injection Quantity :

Adjust- ing Point	Rod Position (mm)	Pump Speed (r.p.m)	Injection Q'ty (cc/1000 strokes)	Max. var bet. cyl (%)	Fixed	Remarks
	12.3	1,000	40.0 ~ 42.0	±2.5	Rack	Basic
	11.7	2,000	39.0 ~ 42.2	±4	Rack	
	12.3	1,000	40.0 ~ 42.0	-	Lever	Basic
	Approx. 8.2	300	6.9 ~ 9.1	-	Lever	

5. Timing Advance Specification :

Pump Speed (r.p.m)	500	800	1,200	1,800	2,000	
Advance Angle (deg.)	Below 0.5	0.1~1.1	1.5~2.5	4.5~5.5	Finish 5.5~6.5	

3. GOVERNOR ADJUSTMET

101441-9121 2/4

(1)Pneumatic Governor

(2)Mechanical Governor

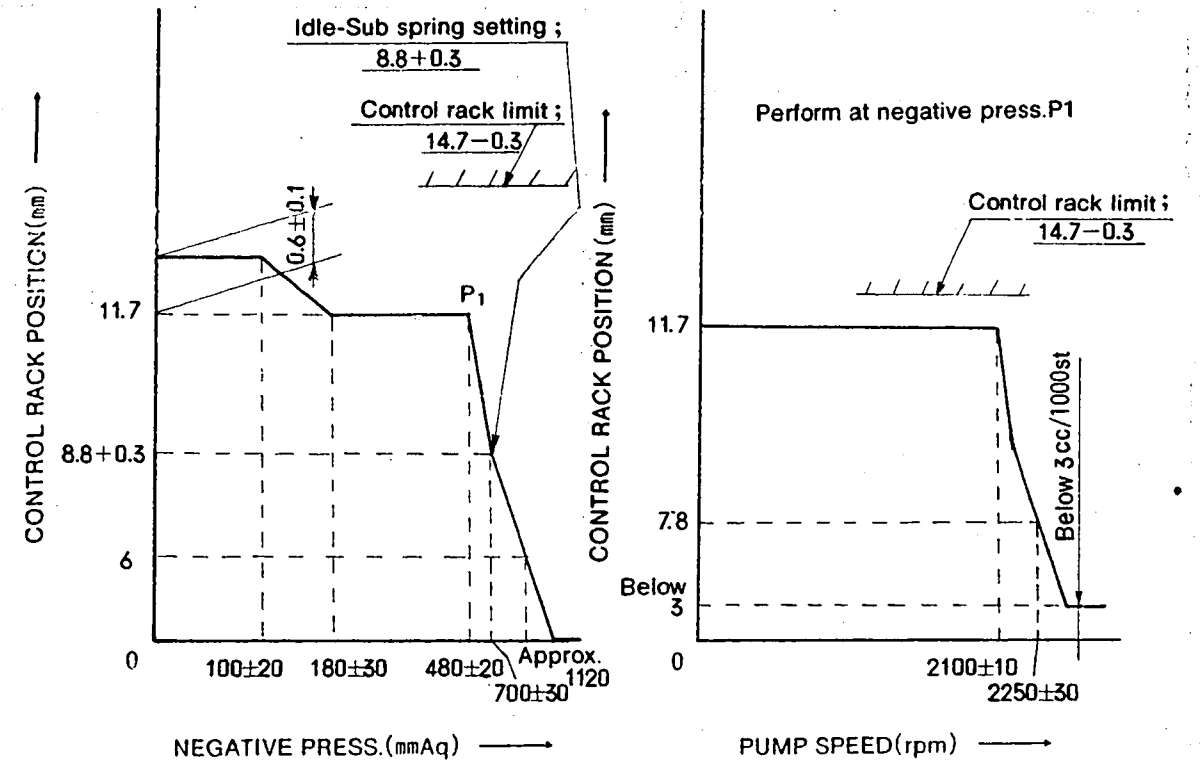

■ Air Tightness Test

1. Increase the pressure of the pneumatic governor's negative pressure chamber to 300 mmAq at a pump speed of 500 rpm and a control rack position of Approx.12.3 mm.
2. Then, confirm that it takes 10 seconds or more for the negative pressure to fall from 500 mmAq to 480 mmAq.

■ Adjustment

1. Pneumatic Governor (Pump Speed : 500 rpm)

Item	Negative Press. (mmAq)	Rack Position (mm)	Remarks
Smoke Set Screw Adjust- ment	0	Approx.12.3	• Adjust using spring capsule ①.
Torque Control Adjustment			
①Start of torque control spring movement	80~120	Approx.12.3	• Adjust thickness of shim ①.
②End of torque control spring movement	150~210	11.7	• Adjust thickness of shim ②.
③Confirm	---	---	
④Confirm torque control stroke	---	---	• inspection : 0.6±0.1 mm

Item	Negative Press. (mmAq)	Rack Position (mm)	Remarks
High-speed control Adjustment	460~500	11.7	• Adjust thickness of shim ③.
Idling Adjustment	670~730 Approx.1120	8.5~9.1 6.0	• Adjust using spring capsule ②. • Confirm

2. Mechanical Governor (Negative pressure: 460~500 mmAq)

Item	Pump Speed (rpm)	Rack Position (mm)	Remarks
Maximum Speed Control Adjustment	2090~2110	11.7	• Adjust using screw ①.
	2220~2280	7.8	• Confirm
	Approx.2600	Below 3	• Confirm (Check the fuel injection quantity: below 3 cc/1000st)

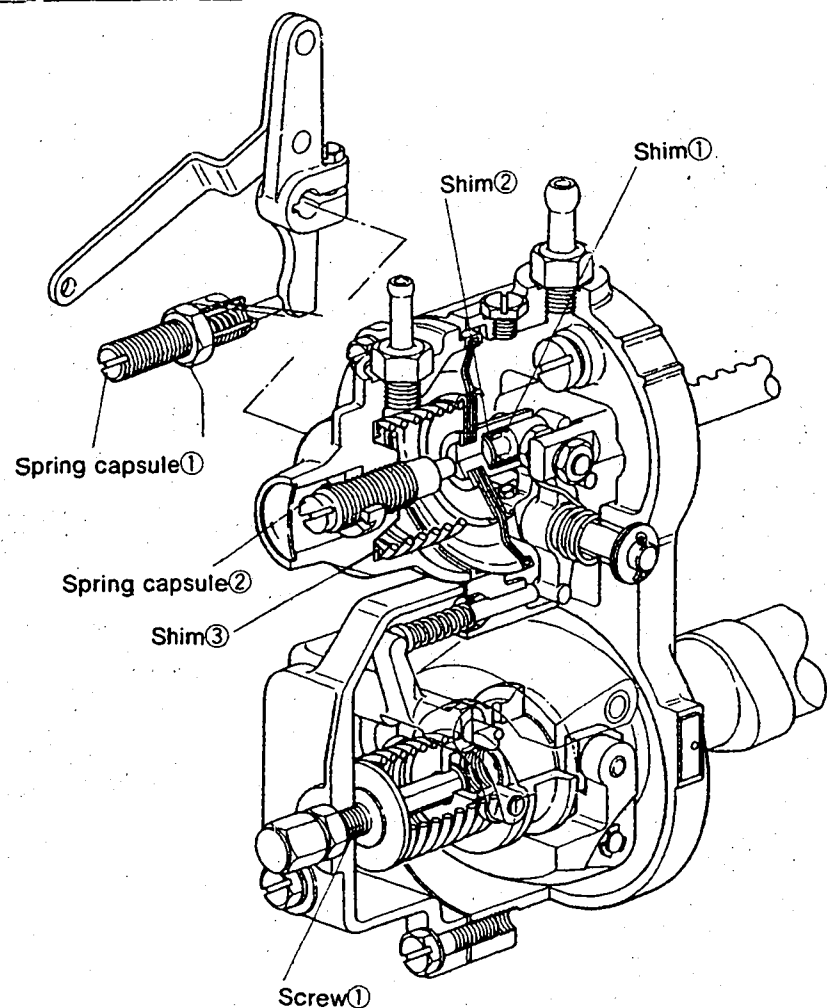

■ Final Adjustment

Smoke Screw Setting			Fuel Injection Quantity Adjustment		
Pump Speed (rpm)	Negative Press. (mmAq)	Injection Q'ty (cc/1000st)	Pump Speed (rpm)	Negative Press. (mmAq)	Injection Q'ty (cc/1000st)
1000	0	40.5~41.5	—	—	—
			—	—	—
			—	—	—
			—	—	—
			—	—	—

⊠ Timing Setting

At No.1 plunger's beginning of injection position.
B.T.D.C. : 18°

Pump center line

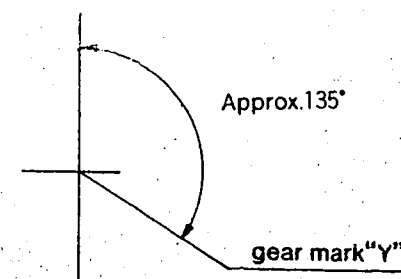

INJ. PUMP CALIBRATION DATA

ENGINE MODEL SD23

BOSCH No.9 400 610 010
 DKKC No. 101441-9131
 Date: 20.Nov.1986
 Company: NISSAN DIESEL
 No. 1670009W60

Injection pump : PES4A Governor : EP/RBD Timing device : EP/SCD
 101044-8100 105542-3850 105622-1060

1. Test Conditions :

Pump rotation : clockwiseviewed from drive side

Nozzle & Nozzle Holder Ass'y : 105780-0000 (BOSCH Type No.DN12SD12) Nozzle Holder : 105780-2080 (BOSCH Type No.EF8511/9A)
 Nozzle opening pressure : 175 Kg/cm² Transfer pump pressure : 1.6 Kg/cm²

Injection pipe : Inner Dia. 2 mm X Outer Dia. 6 mm - Length 600 mm

Test Oil : ISO4113 or SAE Standard Test Oil (SAE J967d) Oil Temp. : 40^{±5} °C

Overflow valve opening pressure : Kg/cm²

2. Injection Timing :

Pre-stroke : No. 1 Plunger 2.15 ±0.05mm
 Note : Adjust with control rod position of mm

Injection order : 1 ~ 3 ~ 4 ~ 2 (interval : 90°±30')
 Plungers are numbered from the Drive side.

Tappet clearance : Bolt adjustment type ; More than 0.3mm for all cylinders.
 Shim adjustment type ; Manually rotate the camshaft 2~3 times and confirm that it rotates smoothly.

4. Injection Quantity :

Adjusting Point	Rod Position (mm)	Pump Speed (r.p.m)	Injection Q'ty (cc/1000 strokes)	Max. var bet. cyl (%)	Fixed	Remarks
	12.0	1,000	37.8 ~ 39.8	±2.5	Rack	Basic
	11.2	2,000	35.9 ~ 39.1	±4	Rack	
	12.0	1,000	37.8 ~ 39.8	-	Lever	Basic
	Approx. 8.2	300	6.9 ~ 9.1	-	Lever	

5. Timing Advance Specification :

Pump Speed (r.p.m)	Below 550	500	1,200	2,150			
Advance Angle (deg.)	Start	Below 0.5	1.5~2.5	Finish 6.5~7.5			

3. GOVERNOR ADJUSTMET

101441-9131 2/4

(1)Pneumatic Governor

(2)Mechanical Governor

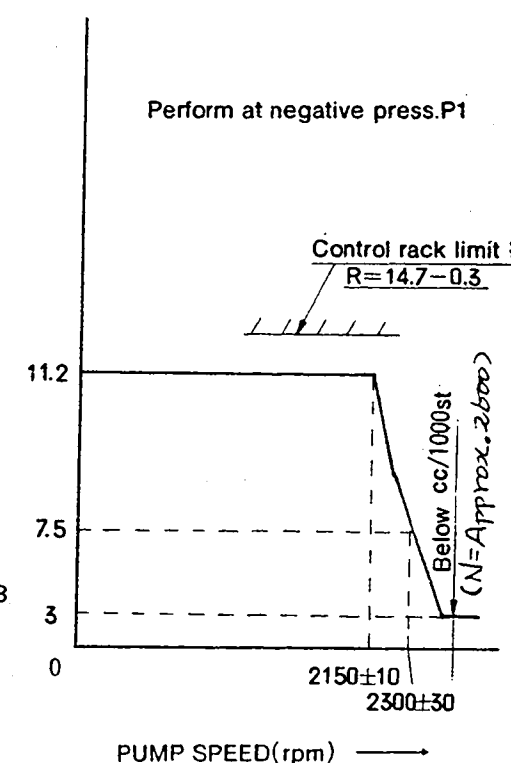
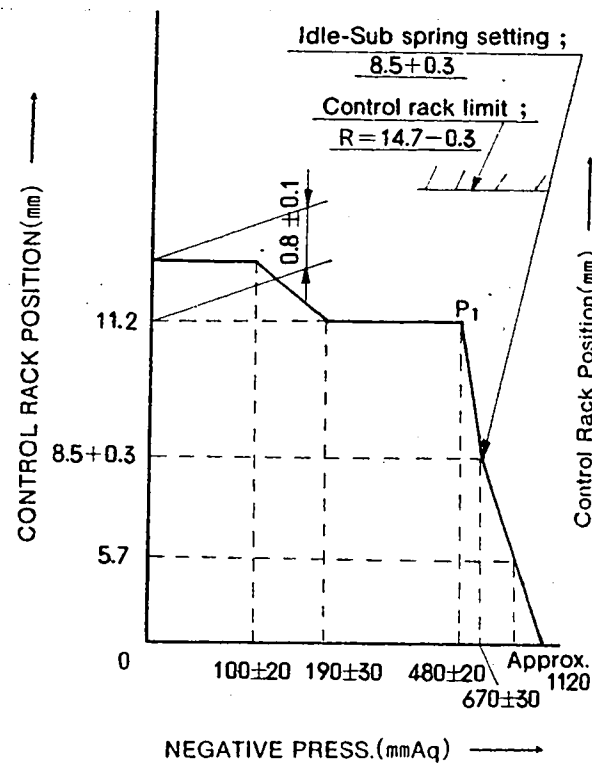

■ Air Tightness Test

1. Increase the pressure of the pneumatic governor's negative pressure chamber to 400 mmAq at a pump speed of 500rpm and a control rack position of approx.12 mm.
2. Then, confirm that it takes 10 seconds or more for the negative pressure to fall from 500 mmAq to 480 mmAq.

■ Adjustment

1. Pneumatic Governor (Pump Speed : 500 rpm)

Item	Negative Press. (mmAq)	Rack Position (mm)	Remarks
Smoke Set Screw Adjust-ment	0	Approx.12	• Adjust using spring capsule ①.
Torque Control Adjustment			
①Start of torque control spring movement	80~120	Approx.12	• Adjust thickness of shim ①.
②End of torque control spring movement	160~220	11.2	• Adjust thickness of shim ②.
③Confirm	—	—	
④Confirm torque control stroke	—	—	• Inspection : 0.8±0.1 mm



Item	Negative Press. (mmAq)	Rack Position (mm)	Remarks
High-speed control Adjustment	460~500	11.2	• Adjust thickness of shim ③.
Idling Adjustment	640~700 Approx.1120	8.2~8.8 5.7	• Adjust using spring capsule ②. • Confirm

2. Mechanical Governor (Negative pressure: 460~520 mmAq)

Item	Pump Speed (rpm)	Rack Position (mm)	Remarks
Maximum Speed Control Adjustment	2140~2160 2270~2330 Approx.2600	11.2 7.5 Below 3	• Adjust using screw ①. • Confirm • Confirm (Check the fuel injection quantity:below 3 cc/1000st)

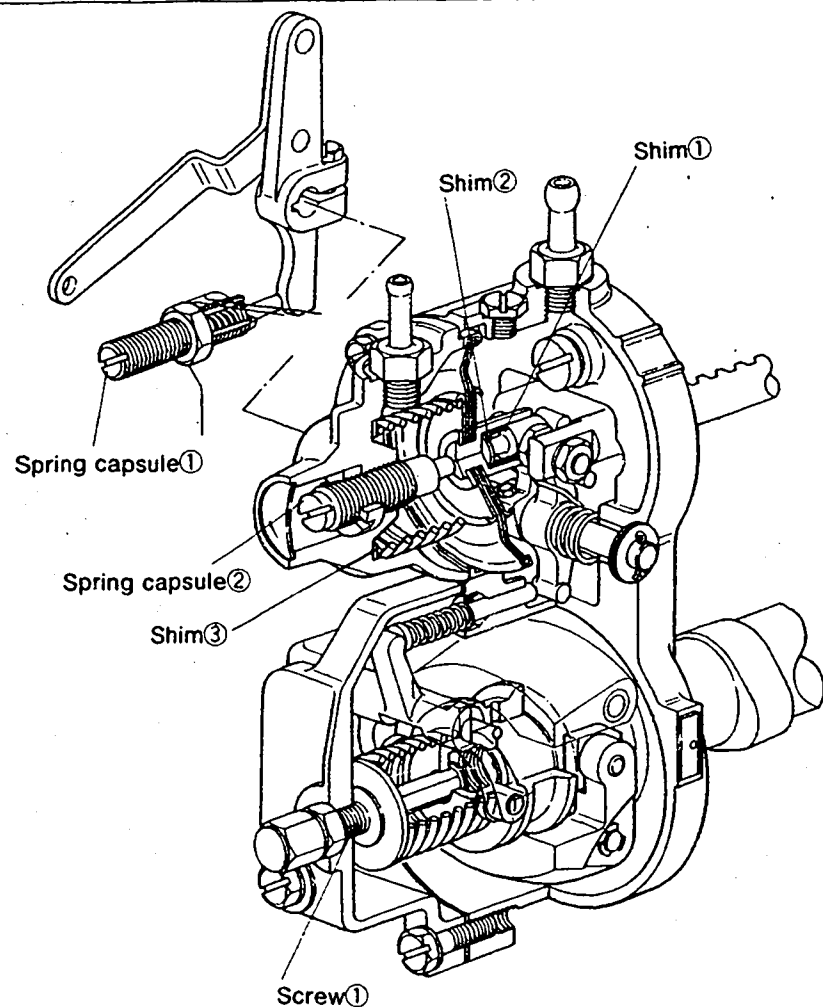

■ Final Adjustment

Smoke Screw Setting			Fuel Injection Quantity Adjustment		
Pump Speed (rpm)	Negative Press. (mmAq)	Injection Q'ty (cc/1000st)	Pump Speed (rpm)	Negative Press. (mmAq)	Injection Q'ty (cc/1000st)
1000	0	38.3~39.3	—	—	—
			—	—	—
			—	—	—
			—	—	—
			—	—	—
			—	—	—

■ Timing Setting

At No.1 plunger's beginning of injection position.
B.T.D.C. : 18°

Pump center line

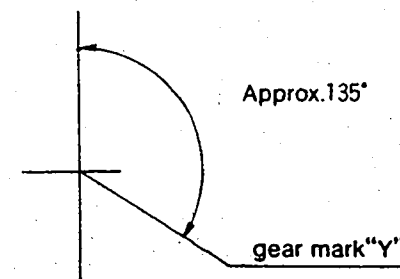

INJ. PUMP CALIBRATION DATA

ENGINE MODEL SD25

BOSCH No.9 400 610 036
 DKKC No. 101441-9200
 Date : 20.Nov.1986 [Q]
 Company : NISSAN DIESEL
 No. 16700T8267

Injection pump : PES4A 101044-8100 Governor : EP/RBD 105542-3920 Timing device : EP/SCD 105622-1160

1. Test Conditions :

Pump rotation : clockwise viewed from drive side

Nozzle & Nozzle Holder Ass'y : 105780-0000 (BOSCH Type No.DN12SD12) Nozzle Holder : 105780-2080 (BOSCH Type No.EF8511/9A)

Nozzle opening pressure : 175 Kg/cm² Transfer pump pressure : 1.6 Kg/cm²

Injection pipe : Inner Dia. 2 mm X Outer Dia. 6 mm - Length 600 mm

Test Oil : ISO4113 or SAE Standard Test Oil (SAE J967d) Oil Temp. : 40^{±5} °C

Overflow valve opening pressure : Kg/cm²

2. Injection Timing :

Pre-stroke : No. 1 Plunger 2.15 ±0.05mm
 Note : Adjust with control rod position of mm

Injection order : 1 ~ 3 ~ 4 ~ 2 (interval : 90° ±30°)

Plungers are numbered from the Drive side.

Tappet clearance : Bolt adjustment type ; More than 0.3mm for all cylinders.
 : Shim adjustment type ; Manually rotate the camshaft 2~3 times and confirm that it rotates smoothly.

4. Injection Quantity :

Adjusting Point	Rod Position (mm)	Pump Speed (r.p.m)	Injection Q'ty (cc/1000 strokes)	Max. var bet. cyl (%)	Fixed	Remarks
	12.4	1,000	41.1 ~ 43.1	±25	Rack	Basic
	Approx. 8.2	300	6.9 ~ 9.1	±15	Rack	
	12.4	1,000	41.1 ~ 43.1	-	Lever	Basic

5. Timing Advance Specification :

Pump Speed (r.p.m)	500	800	1,200	1,800	2,000	
Advance Angle (deg.)	Below 0.5	0.1~1.1	1.5~2.5	4.5~5.5	Finish 5.5~6.5	

3. GOVERNOR ADJUSTMET

101441-9200 2/4

(1)Pneumatic Governor

(2)Mechanical Governor

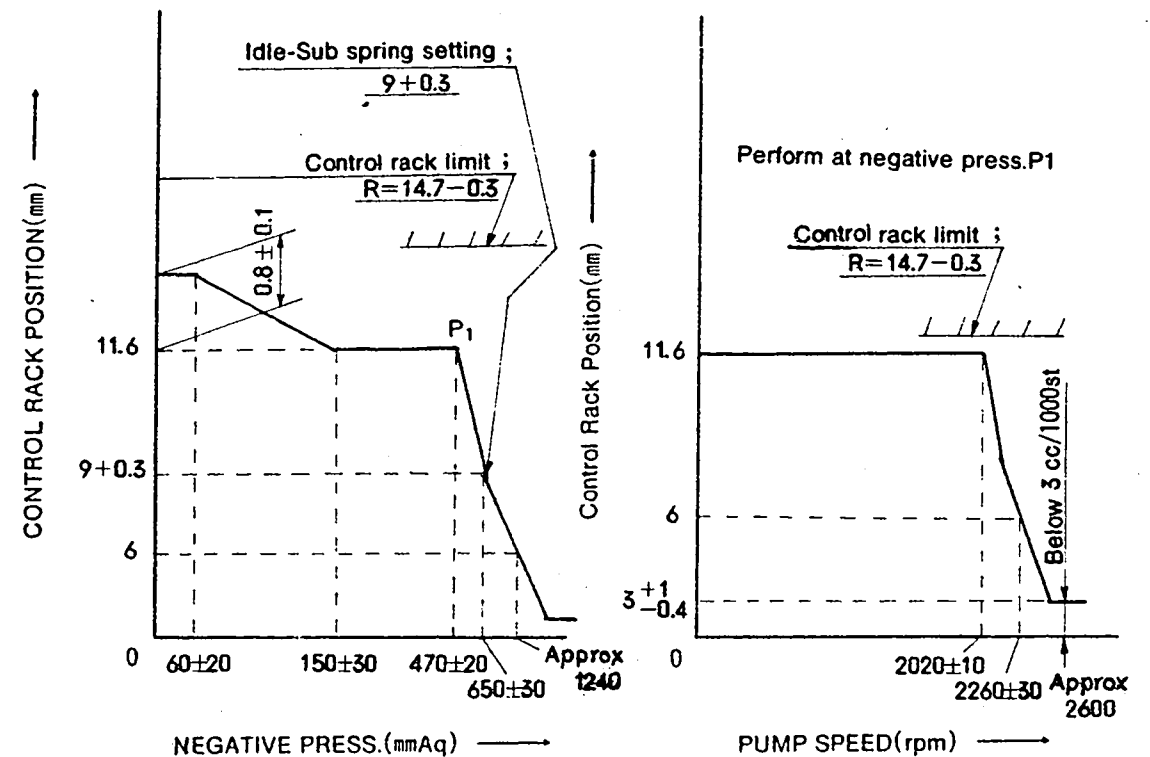

■ Air Tightness Test

1. Increase the pressure of the pneumatic governor's negative pressure chamber to 400 mmAq at a pump speed of 500 rpm and a control rack position of Approx.12.4 mm.
2. Then, confirm that it takes 10 seconds or more for the negative pressure to fall from 500 mmAq to 480 mmAq.

■ Adjustment

1. Pneumatic Governor (Pump Speed : 500 rpm)

Item	Negative Press. (mmAq)	Rack Position (mm)	Remarks	
Smoke Set Screw Adjustment	0	12.4	• Adjust using spring capsule ①.	
Torque Control Adjustment				
	①Start of torque control spring movement	40~80	Approx.12.4	• Adjust thickness of shim ①.
	②End of torque control spring movement	120~180	11.6	• Adjust thickness of shim ②.
	③Confirm	---	---	
④Confirm torque control stroke	---	---	• Inspection : 0.8±0.1 mm	

Item	Negative Press. (mmAq)	Rack Position (mm)	Remarks
High-speed control Adjustment	450~490	11.6	• Adjust thickness of shim ③.
Idling Adjustment	620~680 Approx.1240	9~9.3 6	• Adjust using spring capsule ②. • Confirm

2. Mechanical Governor (Negative pressure: 450~490 mmAq)

Item	Pump Speed (rpm)	Rack Position (mm)	Remarks
Maximum Speed Control Adjustment	2010~2030 2230~2290 Approx.2600	11.6 6 2.6~4	• Adjust using screw ①. • Confirm • Confirm (Check the fuel injection quantity: below 3 cc/1000st)

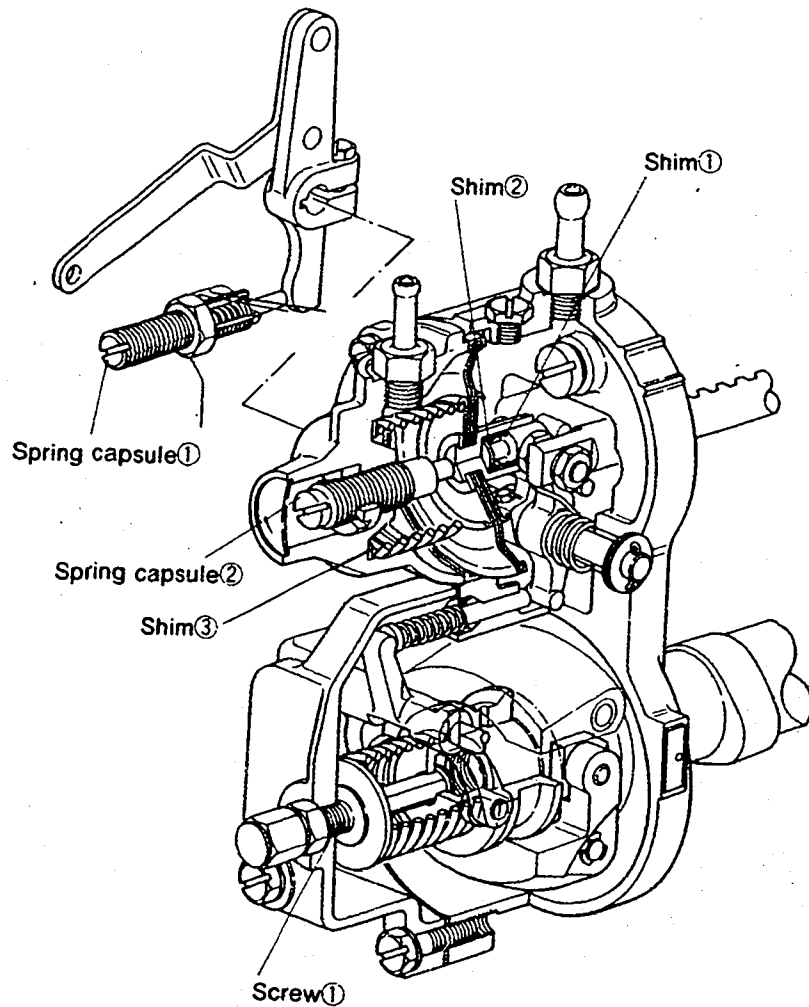

■ Final Adjustment

Smoke Screw Setting			Fuel Injection Quantity Adjustment		
Pump Speed (rpm)	Negative Press. (mmAq)	Injection Q'ty (cc/1000st)	Pump Speed (rpm)	Negative Press. (mmAq)	Injection Q'ty (cc/1000st)
1000	0	41.6~42.6	—	—	—
			—	—	—
			—	—	—
			—	—	—
			—	—	—
			—	—	—

■ Timing Setting

At No.1 plunger's beginning of injection position.

B.T.D.C. : 18°

Pump center line

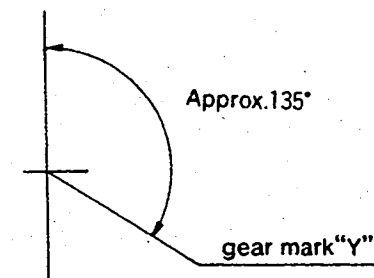

INJ. PUMP CALIBRATION DATA

ENGINE MODEL ED33

BOSCH No.9 400 610 037
 DKKC No. 101451-9400
 Date: 20.Nov.1986 ③
 Company: NISSAN DIESEL
 No. 16700T9001

Injection pump : PES4A Governor : EP/RBD Timing device : EP/SCD
 101045-9250 105542-3771 105622-1020

1. Test Conditions :

Pump rotation : clockwise viewed from drive side
 Nozzle & Nozzle Holder Ass'y : 105780-0000 (BOSCH Type No.DN12SD12) Nozzle Holder : 105780-2080 (BOSCH Type No.EF8511/9A)
 Nozzle opening pressure : 175 Kg/cm² Transfer pump pressure : 1.6 Kg/cm²
 Injection pipe : Inner Dia. 2 mm X Outer Dia. 6 mm - Length 600 mm
 Test Oil : ISO4113 or SAE Standard Test Oil (SAE J967d) Oil Temp. : 40⁺⁵ °C
 Overflow valve opening pressure : Kg/cm²

2. Injection Timing :

Pre-stroke : No. 1 Plunger 2.0 ±0.05mm
 Note : Adjust with control rod position of mm
 Injection order : 1 ~ 3 ~ 4 ~ 2 (interval : 90° ±30°)
 Plungers are numbered from the Drive side.
 Tappet clearance : Bolt adjustment type ; More than 0.3mm for all cylinders.
 : Shim adjustment type ; Manually rotate the camshaft 2~3 times and confirm that it rotates smoothly.

4. Injection Quantity :

Adjusting Point	Rod Position (mm)	Pump Speed (r.p.m)	Injection Q'ty (cc/1000 strokes)	Max. var bet. cyl (%)	Fixed	Remarks
	12.3	1,000	55.0 ~ 57.0	±2.5	Rack	Basic
	11.9	1,750	58.2 ~ 62.2	±4	Rack	
	Approx. 7.7	300	7.5 ~ 12.1	±15	Rack	

5. Timing Advance Specification :

Pump Speed (r.p.m)	Above 300	400	450	700	1,500	1,900	
Advance Angle (deg.)	Start	Below 0.5	Below 0.7	0.5~1.5	4.5~5.5	Finish 7.0~8.0	

3. GOVERNOR ADJUSTMET

101451-9400 2/4

(1)Pneumatic Governor

(2)Mechanical Governor

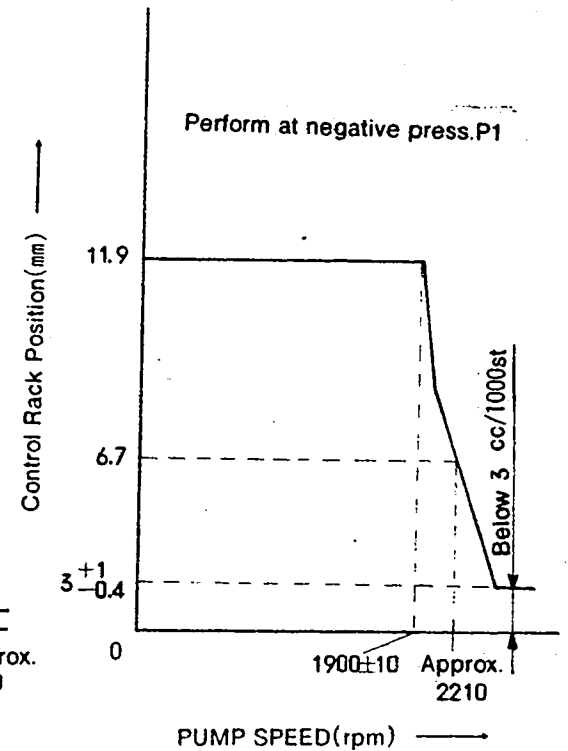
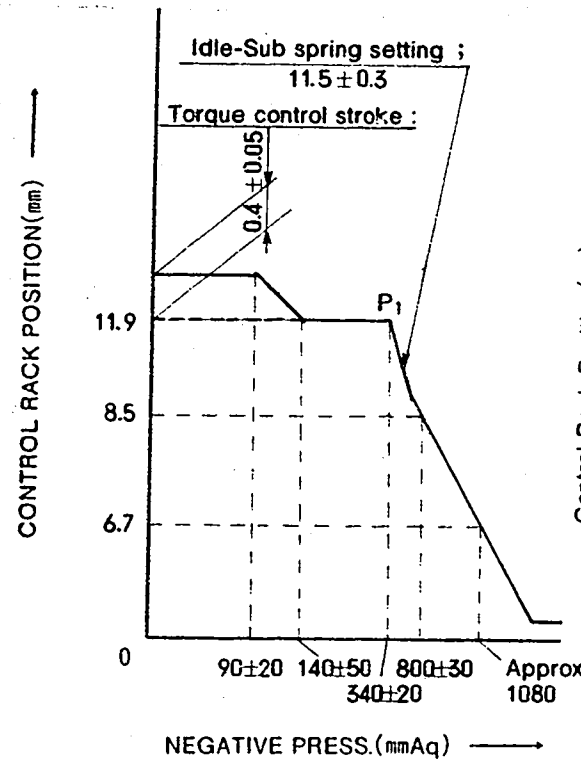

■ Air Tightness Test

- Increase the pressure of the pneumatic governor's negative pressure chamber to 300 mmAq at a pump speed of 500 rpm and a control rack position of 12.3 mm.
- Then, confirm that it takes 10 seconds or more for the negative pressure to fall from 500 mmAq to 480 mmAq.

■ Adjustment

- Pneumatic Governor (Pump Speed : 500 rpm)

Item	Negative Press. (mmAq)	Rack Position (mm)	Remarks
Smoke Set Screw Adjustment	0	Approx.12.3	• Adjust using spring capsule ①.
Torque Control Adjustment			
① Start of torque control spring movement	70~110	Approx.12.3	• Adjust thickness of shim ①.
② End of torque control spring movement	90~190	11.9	• Adjust thickness of shim ②.
③ Confirm			
④ Confirm torque control stroke			• Inspection : 0.4 ± 0.05 mm

Item	Negative Press. (mmAq)	Rack Position (mm)	Remarks
High-speed control Adjustment	320~360	11.9	• Adjust thickness of shim ③.
Idling Adjustment	770~830	8.5	• Adjust using spring capsule ②.
	Approx.1080	6.7	• Confirm

2. Mechanical Governor (Negative pressure: 320~360 mmAq)

Item	Pump Speed (rpm)	Rack Position (mm)	Remarks
Maximum Speed Control Adjustment	1890~1910	11.9	• Adjust using screw ①.
	Approx.2210	6.7	• Confirm
	Approx.2300	2.6~4	• Confirm (Check the fuel injection quantity: below 3 cc/1000st)

■ Final Adjustment

Smoke Screw Setting			Fuel Injection Quantity Adjustment		
Pump Speed (rpm)	Negative Press. (mmAq)	Injection Q'ty (cc/1000st)	Pump Speed (rpm)	Negative Press. (mmAq)	Injection Q'ty (cc/1000st)
1000	0	55.5~56.5	---	---	---
			---	---	---
			---	---	---
			---	---	---
			---	---	---
			---	---	---

■ Timing Setting

At No.1 plunger's beginning of injection position.

B.T.D.C. : 12°

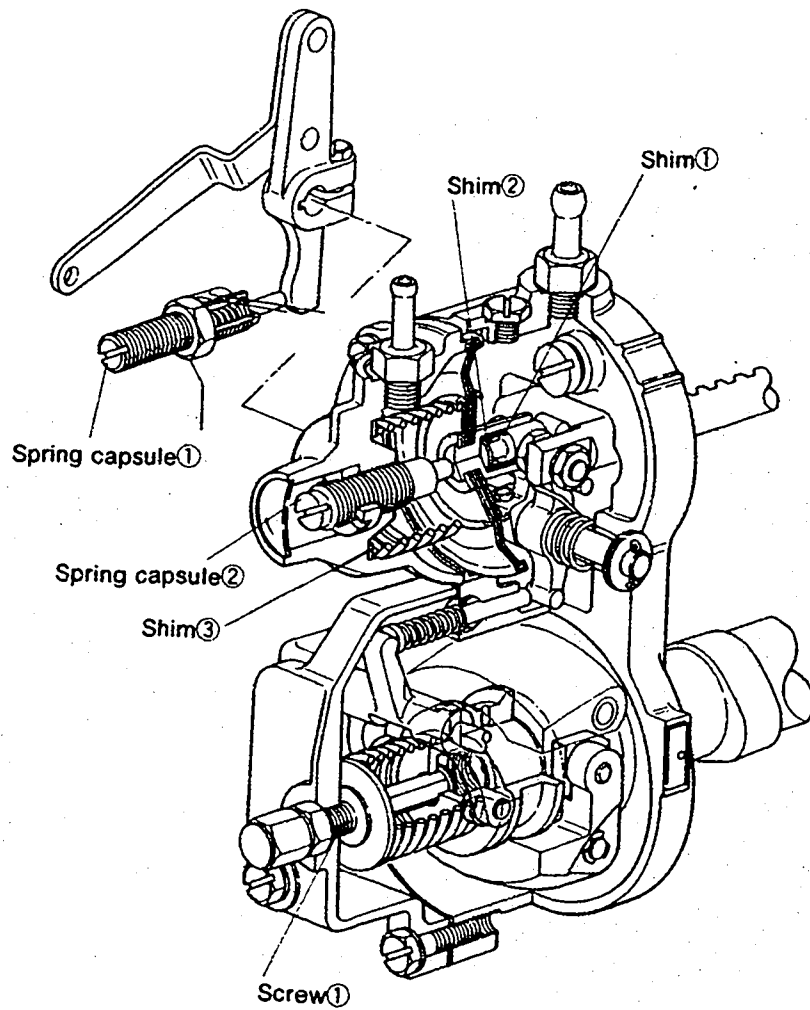

Pump center line

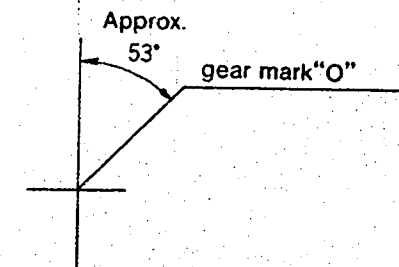

INJ. PUMP CALIBRATION DATA

ENGINE MODEL 4BA1

BOSCH No.9 400 610 011
 DKKC No. 101461-0410
 Date: 20.Nov.1986
 Company: ISUZU
 No. 5-15601-325-1

Injection pump : PES4A 101046-8160 Governor : EP/RBD 105542-3580 Timing device : EP/SCD 105622-0980

1. Test Conditions :

Pump rotation : clockwise viewed from drive side
 Nozzle & Nozzle Holder Assy : 105780-0000 (BOSCH Type No.DN12SD12) Nozzle Holder : 105780-2080 (BOSCH Type No.EF8511/9A)
 Nozzle opening pressure : 175 Kg/cm² Transfer pump pressure : 1.6 Kg/cm²
 Injection pipe : Inner Dia. 2 mm X Outer Dia. 6 mm - Length 600 mm
 Test Oil : ISO4113 or SAE Standard Test Oil (SAE J967d) Oil Temp. : 40^{±5} °C
 Overflow valve opening pressure : 1.6 Kg/cm²

2. Injection Timing :

Pre-stroke : No. 1 Plunger 1.95 ±0.05mm
 Note : Adjust with control rod position of approx.11.1 mm
 Injection order : 1 ~ 3 ~ 4 ~ 2 (interval : 90 °±30')

Plungers are numbered from the Drive side.

Tappet clearance : Bolt adjustment type : More than 0.3mm for all cylinders.
 Shim adjustment type : Manually rotate the camshaft 2~3 times and confirm that it rotates smoothly.

4. Injection Quantity :

Adjusting Point	Rod Position (mm)	Pump Speed (r.p.m)	Injection Q'ty (cc/1000 strokes)	Max. var bet. cyl (%)	Fixed	Remarks
	11.1	1,750	44.3 ~ 47.3	±2.5	Rack	Basic
	Approx. 8.9	300	7.1 ~ 9.9	±14	Rack	
	Above 16.5	150	Above 75.0	-	Lever	Basic Ecessive fuel setting for starting

5. Timing Advance Specification :

Pump Speed (r.p.m)	500	700	1,000	1,400	1,750		
Advance Angle (deg.)	Below 0.5	Below 1.0	1.0~2.0	3.5~4.5	Finish 6~7		

3. GOVERNOR ADJUSTMET

101461-0410 2/4

(1)Pneumatic Governor

(2)Mechanical Governor

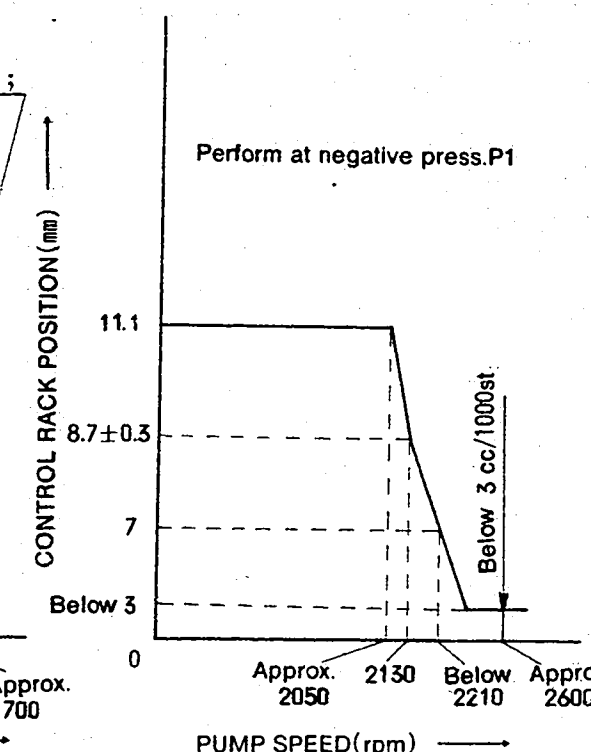
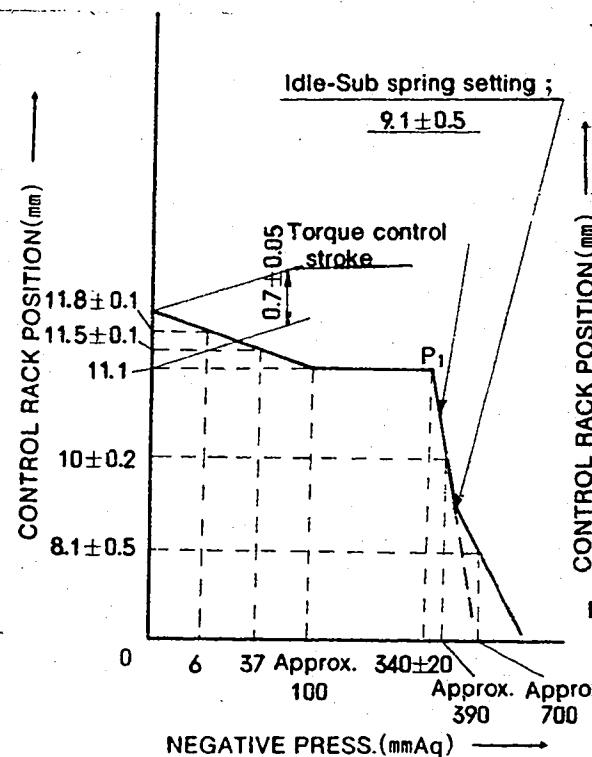

■ Air Tightness Test

1. Increase the pressure of the pneumatic governor's negative pressure chamber to 300 mmAq at a pump speed of 500 rpm and a control rack position of approx. 11.8 mm.
2. Then, confirm that it takes 10 secnds or more for the negative pressure to fall from 500 mmAq to 480 mmAq.

■ Adjustment

1. Pneumatic Governor (Pump Speed : 500 rpm)

Item	Negative Press. (mmAq)	Rack Position (mm)	Remarks
Smoke Set Screw Adjust-ment	0	Approx. 11.8	• Adjust using spring capsufe ①.
Torque Control Adjustment	37	11.4~11.6	• Adjust thickness of shim ①.
	100	11.1	• Adjust thickness of shim ②.
	6	11.7~11.9	
	—	—	• Inspection : 0.7±0.05 mm

Item	Negative Press. (mmAq)	Rack Position (mm)	Remarks
High-speed control Adjustment	320~360	11.1	• Adjust thickness of shim ③.
Idling Adjustment	—	8.6~9.6	• Adjust using spring capsule ②.
	Approx. 390	9.8~10.2	
	Approx. 700	7.6~8.5	• Confirm

2. Mechanical Governor (Negative pressure: 320~360 mmAq)

Item	Pump Speed (rpm)	Rack Position (mm)	Remarks
Maximum Speed Control Adjustment	Approx. 2050	11.1	• Adjust using screw ①.
	2130	8.4~9.0	• Confirm
	Below 2290	7	• Confirm
	Approx. 2600	Below 3	• Confirm (Check the fuel injection quantity: below 3 cc/1000st)

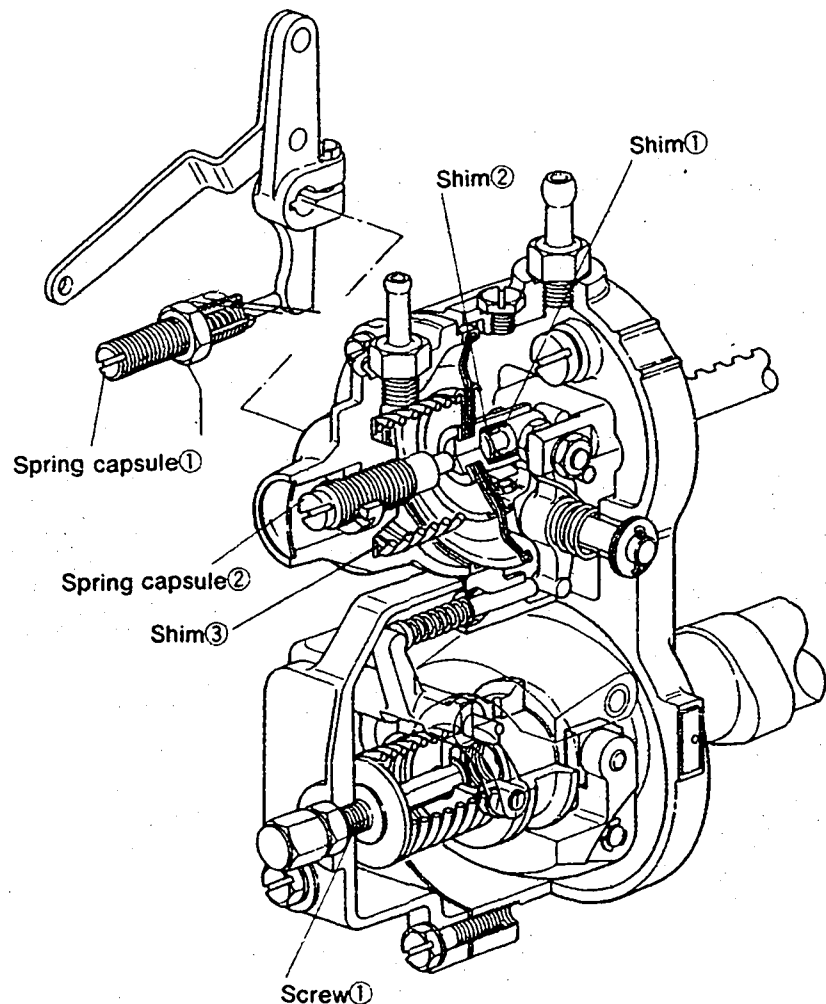

■ Final Adjustment

Smoke Screw Setting			Fuel Injection Quantity Adjustment		
Pump Speed (rpm)	Negative Press. (mmAq)	Injection Q'ty (cc/1000st)	Pump Speed (rpm)	Negative Press. (mmAq)	Injection Q'ty (cc/1000st)
1750	160	45.3~46.3	500	6	(39.2~41.2)
			750	6	(43.5~46.5)
			1100	37	46.3~48.3
			1850	180	(44.5~46.5)
			2000	206	(43.3~45.3)
			2600	340	Below 3

■ Timing Setting

At No.1 plunger's beginning of injection position.
B.T.D.C.: 10°

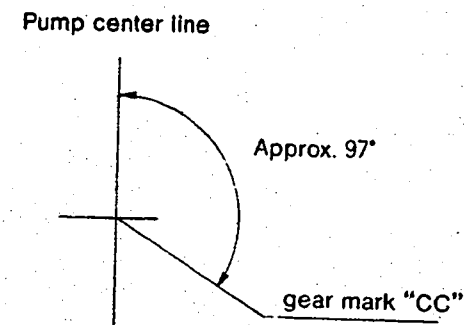

INJ. PUMP CALIBRATION DATA

ENGINE MODEL 4BA1

BOSCH No.9 400 610 012
 DKKC No. 101461-0471
 Date: 20.Nov.1986
 Company: ISUZU
 No. 5-15601-440-1

Injection pump : PES4A 101046-8250 Governor : EP/RBD 105542-3580 Timing device : EP/SCD 105622-1190

1. Test Conditions :

Pump rotation : clockwise viewed from drive side
 Nozzle & Nozzle Holder Ass'y : 105780-0000 (BOSCH Type No.DN12SD12) Nozzle Holder : 105780-2080 (BOSCH Type No.EF8511/9A)
 Nozzle opening pressure : 175 Kg/cm² Transfer pump pressure : 1.6 Kg/cm²
 Injection pipe : Inner Dia. 2 mm X Outer Dia. 6 mm - Length 600 mm
 Test Oil : ISO4113 or SAE Standard Test Oil (SAE J967d) Oil Temp. : 40^{±5}°C
 Overflow valve opening pressure : Kg/cm²

2. Injection Timing :

Pre-stroke : No. 1 Plunger 1.95 ±0.05mm
 Note : Adjust with control rod position of 11.1 mm
 Injection order : 1 ~ 3 ~ 4 ~ 2 (interval : 90° ±30')
 Plungers are numbered from the Drive side.
 Tappet clearance : Bolt adjustment type : More than 0.3mm for all cylinders.
 Shim adjustment type : Manually rotate the camshaft 2~3 times and confirm that it rotates smoothly.

4. Injection Quantity :

Adjusting Point	Rod Position (mm)	Pump Speed (r.p.m)	Injection Q'ty (cc/1000 strokes)	Max. var bet. cyl (%)	Fixed	Remarks
	11.1	1,750	44.3 ~ 47.3	±2.5	Rack	Basic
	Approx. 8.9	300	7.1 ~ 9.9	±14	Rack	
	Above 16.5	150	Above 75.0	-	Rack	Basic Ecessive fuel setting for starting

5. Timing Advance Specification :

Pump Speed (r.p.m)	800	1,000	1,400	1,750
Advance Angle (deg.)	Below 0.5	Below 1.0	2.5~3.5	Finish 5~6

3. GOVERNOR ADJUSTMET

101461-0471 2/4

(1) Pneumatic Governor

(2) Mechanical Governor

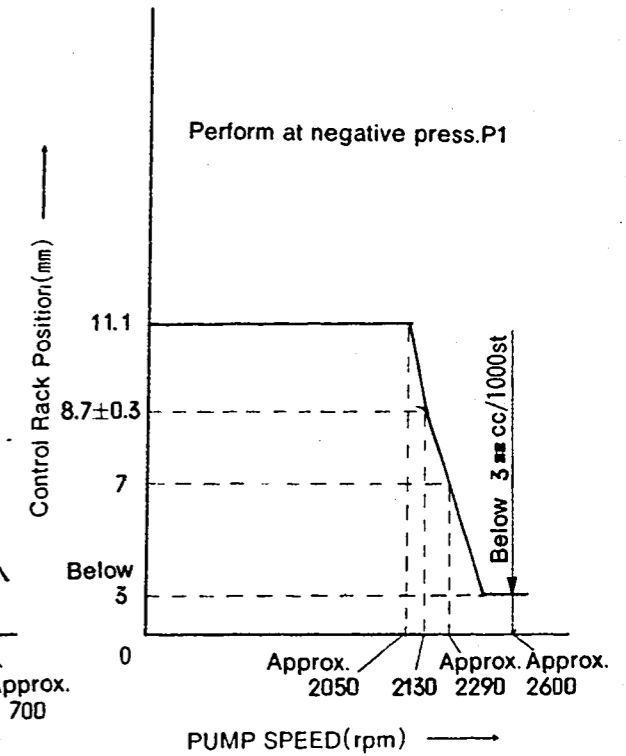
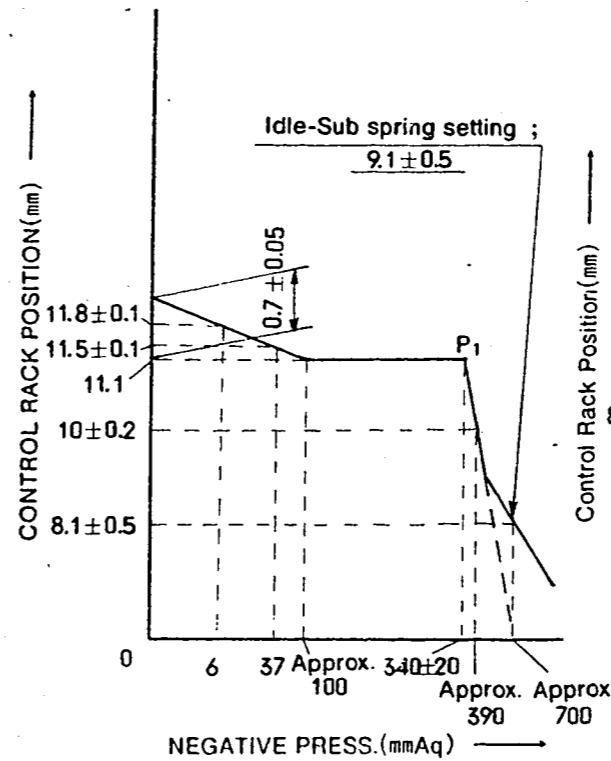

■ Air Tightness Test

1. Increase the pressure of the pneumatic governor's negative pressure chamber to 300mmAq at a pump speed of 500rpm and a control rack position of approx. 11.8 mm. Then, confirm that it takes 10 seconds or more for the negative pressure to fall from 500 mmAq to 480 mmAq.

■ Adjustment

1. Pneumatic Governor (Pump Speed : 500 rpm)

Item	Negative Press. (mmAq)	Rack Position (mm)	Remarks
Smoke Set Screw Adjustment	0	Approx. 11.8	• Adjust using spring capsule ①.
Torque Control Adjustment	37	11.4~11.6	• Adjust thickness of shim ①.
		Approx. 100	11.1
	6	11.7~11.9	
④ Confirm torque control stroke	—	—	• Inspection : 0.7 ± 0.05mm

Item	Negative Press. (mmAq)	Rack Position (mm)	Remarks
High-speed control Adjustment	320~360	11.1	• Adjust thickness of shim ③.
Idling Adjustment	—	8.6~9.6	• Adjust using spring capsule ②. • Confirm
	Approx.390 Approx.700	9.8~10.2 7.6~8.6	

2. Mechanical Governor (Negative pressure:320~360 mmAq)

Item	Pump Speed (rpm)	Rack Position (mm)	Remarks
Maximum Speed Control Adjustment	Approx.2050	11.1	• Adjust using screw ①. • Confirm • Confirm (Check the fuel injection quantity:below 3 cc/1000st)
	2130	8.4~10.0	
	Below 2290 Approx.2600	7 Below 3	

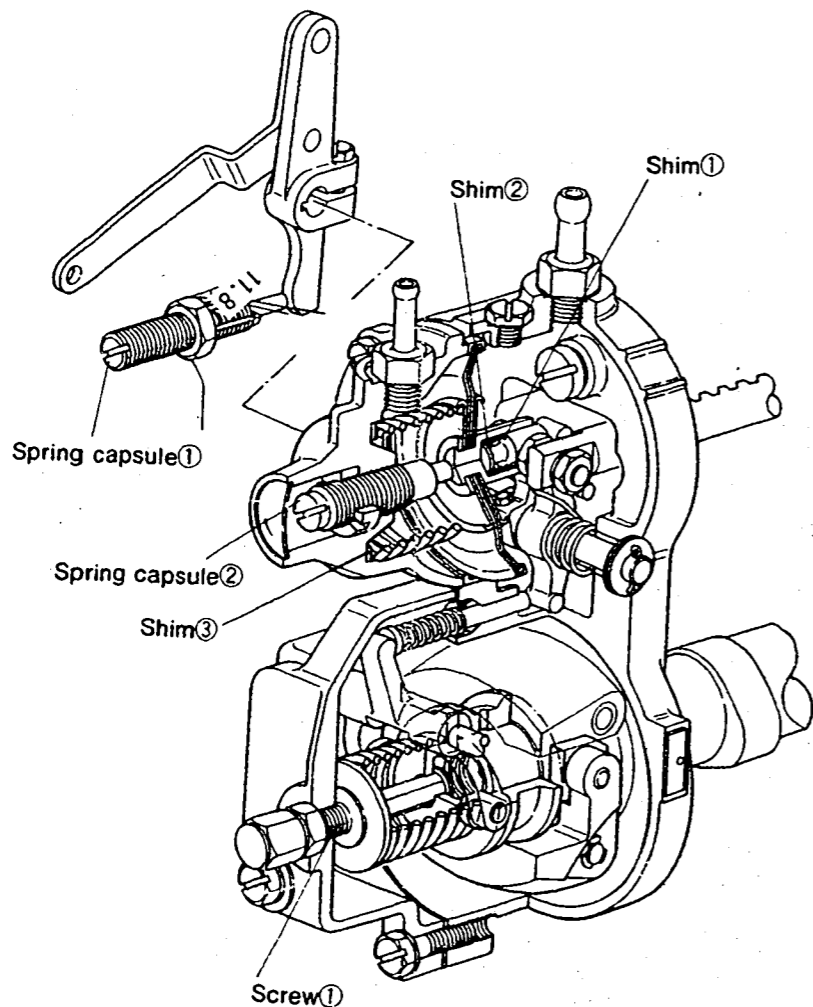

■ Final Adjustment

Smoke Screw Setting			Fuel Injection Quantity Adjustment		
Pump Speed (rpm)	Negative Press. (mmAq)	Injection Q'ty (cc/1000st)	Pump Speed (rpm)	Negative Press. (mmAq)	Injection Q'ty (cc/1000st)
1750	160	45.3~46.3	500	6	(39.2~41.2)
			700	6	(43.5~46.5)
			1100	37	(46.3~48.3)
			1850	180	(44.5~46.5)
			2000	206	(43.3~45.3)
			2600	340	Below 3

■ Timing Setting

At No.1 plunger's beginning of injection position.

B.T.D.C. : 12°

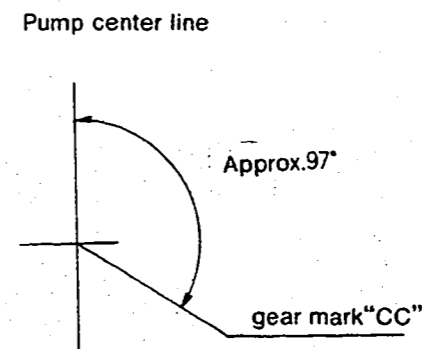

INJ. PUMP CALIBRATION DATA

ENGINE MODEL 4BC1

BOSCH No.9 400 610 013
 DKKC No. 101471-0290
 Date: 20.Nov.1986 0
 Company: ISUZU
 No. 5-15601-326-0

101471-0290 2/4

Injection pump : PES4A 101047-8220 Governor : EP/RBD 105542-3670 Timing device : EP/SCD 105622-0990

1. Test Conditions :

Pump rotation : clockwiseviewed from drive side

Nozzle & Nozzle Holder Ass'y : 105780-0000 (BOSCH Type No.DN12SD12) Nozzle Holder : 105780-2080 (BOSCH Type No.EF8511/9A)

Nozzle opening pressure : 175 Kg/cm² Transfer pump pressure : 1.6 Kg/cm²

Injection pipe : Inner Dia. 2 mm X Outer Dia. 6 mm - Length 600 mm

Test Oil : ISO4113 or SAE Standard Test Oil (SAE J967d) Oil Temp. : 40⁺⁵ °C

Overflow valve opening pressure : Kg/cm²

2. Injection Timing :

Pre-stroke : No. 1 Plunger 2.2 ±0.05mm
 Note : Adjust with control rod position of 11.0 mm

Injection order : 1 ~ 3 ~ 4 ~ 2 (interval : 90 °±30')

Plungers are numbered from the Drive side.

Tappet clearance : Bolt adjustment type : More than 0.3mm for all cylinders.
 : Shim adjustment type : Manually rotate the camshaft 2~3 times and confirm that it rotates smoothly.

4. Injection Quantity :

Adjusting Point	Rod Position (mm)	Pump Speed (r.p.m)	Injection Q'ty (cc/1000 strokes)	Max. var bet. cyl (%)	Fixed	Remarks
A	11	1,750	51.5 ~ 53.5	±2.5	Rack	Basic
B	8.3	300	7.1 ~ 9.9	±14	Rack	
C	Approx. 16	150	84.0 ~ 94.0	—	Lever	Basic Ecessive fuel setting for starting

5. Timing Advance Specification :

Pump Speed (r.p.m)	500	700	1,000	1,400	1,750		
Advance Angle (deg.)	Below 0.5	Below 1.0	1.0~2.0	3.5~4.5	Finish 6~7		

3. GOVERNOR ADJUSTMET

(1)Pneumatic Governor

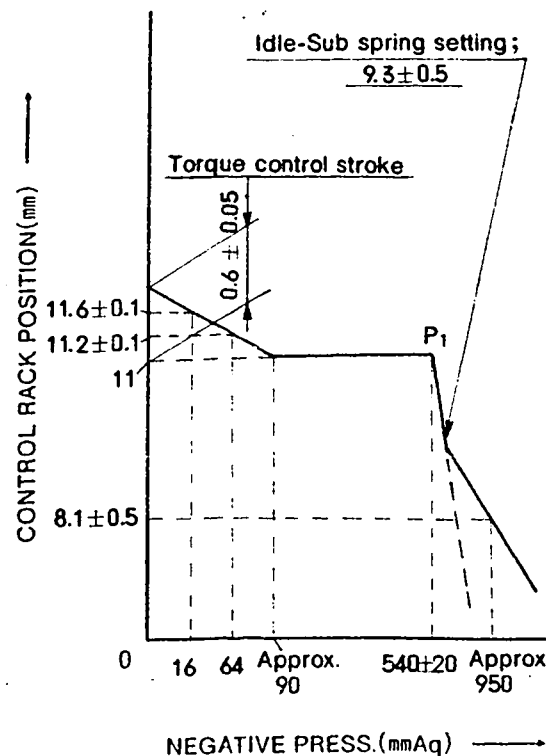

(2)Mechanical Governor

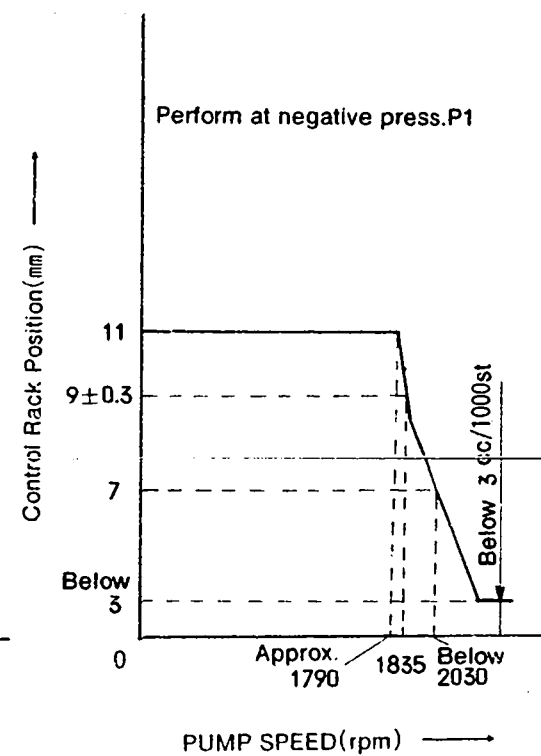

■ Air Tightness Test

- Increase the pressure of the pneumatic governor's negative pressure chamber to 500 mmAq at a pump speed of 500 rpm and a control rack position of approx.11.6 mm
- Then, confirm that it takes 10 seconds or more for the negative pressure to fall from 500 mmAq to 480 mmAq.

■ Adjustment

- Pneumatic Governor (Pump Speed : 500 rpm)

Item	Negative Press. (mmAq)	Rack Position (mm)	Remarks
Smoke Set Screw Adjustment	0	Approx.11.6	• Adjust using spring capsule ①.
Torque Control Adjustment	64	11.1~11.3	• Adjust thickness of shim ①.
	Approx.90	11	• Adjust thickness of shim ②.
	16	11.5~11.7	
	—	—	• Inspection : 0.6±0.05 mm

■ Final Adjustment

Item	Negative Press. (mmAq)	Rack Position (mm)	Remarks
High-speed control Adjustment	520~560	11	• Adjust thickness of shim ③.
Idling Adjustment	— Approx.950	8.8~9.8 7.6~8.6	• Adjust using spring capsule ②. • Confirm

2. Mechanical Governor (Negative pressure: 520~560 mmAq)

Item	Pump Speed (rpm)	Rack Position (mm)	Remarks
Maximum Speed Control Adjustment	Approx.1790	11	• Adjust using screw ①.
	1835	8.7~9.3	
	Below 2030	7	• Confirm
	Approx.2400	Below 3	• Confirm (Check the fuel injection quantity: below 3 cc/1000st)

Smoke Screw Setting			Fuel Injection Quantity Adjustment		
Pump Speed (rpm)	Negative Press. (mmAq)	Injection Q'ty (cc/1000st)	Pump Speed (rpm)	Negative Press. (mmAq)	Injection Q'ty (cc/1000st)
1750	225	52.0~53.0	500	5	46.3~48.3
			700	16	49.8~51.8
			1100	64	53.7~55.7
			1800	236	50.8~52.8
			2400	540	Below 3

■ Timing Setting

At No.1 plunger's beginning of injection position.
B.T.D.C. : 6°

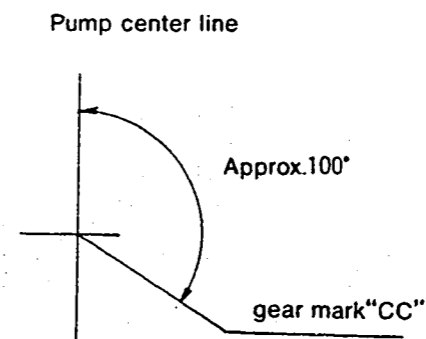
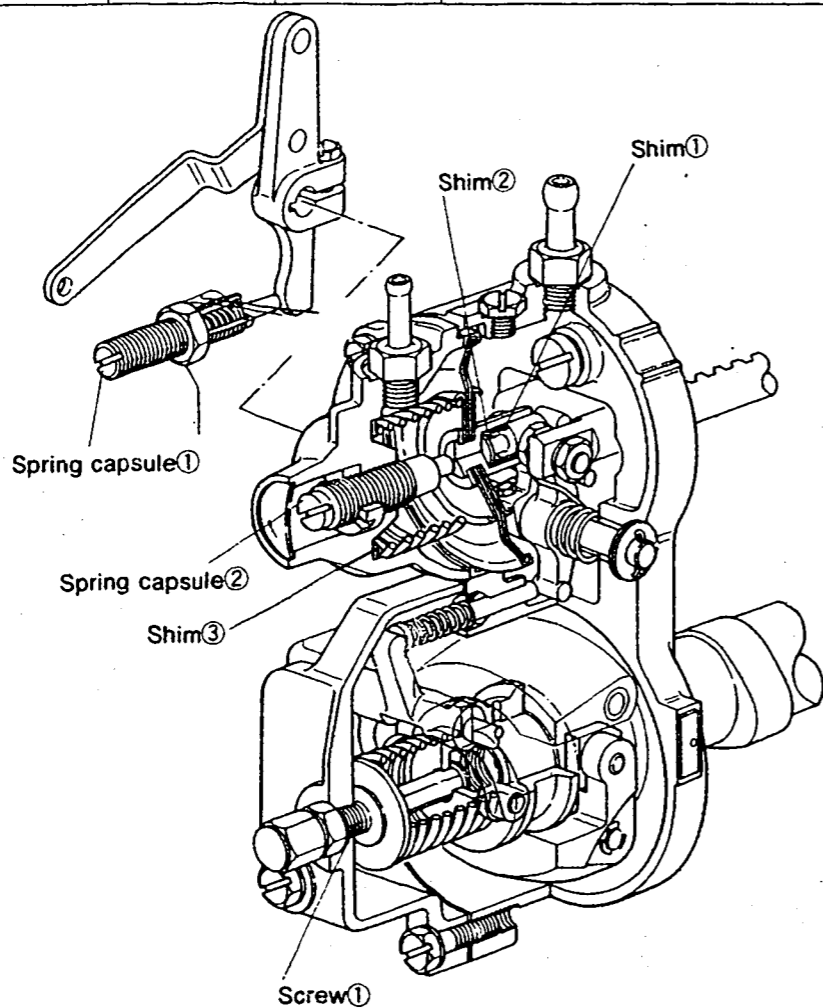

INJ. PUMP CALIBRATION DATA

ENGINE MODEL 4BC2

BOSCH No.9 400 610 014
 DKKC No. 101491-0032
 Date: 20.Nov.1986 [6]
 Company: ISUZU
 No. 5-15601-210-5

Injection pump : PES4A Governor : EP/RLD Timing device : EP/SCD
 101049-8150 105931-0681 105622-0861

1. Test Conditions :

Pump rotation : clockwise viewed from drive side

Nozzle & Nozzle Holder Assy : 105780-0000 Nozzle Holder : 105780-2080
 (BOSCH Type No.DN12SD12) (BOSCH Type No.EF8511/9A)

Nozzle opening pressure : 175 Kg/cm² Transfer pump pressure : 1.6 Kg/cm²

Injection pipe :
 Inner Dia. 2 mm X Outer Dia. 6 mm - Length 600 mm

Test Oil : ISO4113 or SAE Standard Test Oil (SAE J967d) Oil Temp. : 40^{±5} °C

Overflow valve opening pressure : Kg/cm²

2. Injection Timing :

Pre-stroke : No. 1 Plunger 3.4 ±0.05mm
 Note : Adjust with control rod position of 10.2 mm

Injection order : 1 ~ 3 ~ 4 ~ 2 (interval : 90° ±30°)

Plungers are numbered from the Drive side.

Tappet clearance : Bolt adjustment type : More than 0.3mm for all cylinders.
 Shim adjustment type : Manually rotate the camshaft 2~3 times and confirm that it rotates smoothly.

4. Injection Quantity :

Adjusting Point	Rod Position (mm)	Pump Speed (r.p.m)	Injection Q'ty (cc/1000 strokes)	Max. var bet. cyl (%)	Fixed	Remarks
	10.2	1,100	49.4 ~ 52.6	±2.5	Rack	Basic
H	Approx. 9.8	300	8.0 ~ 11.0	±14	Rack	
A	R(10.2)	1,100	50.0 ~ 52.0	—	Lever	Basic
B	(10.1)	1,800	47.6 ~ 50.8	—	Lever	
C	(10.3)	700	38.4 ~ 41.6	—	Lever	
D	11.0	500	40.1 ~ 44.1	—	Lever	
I	Above 15	100	65.0 ~ 81.0	—	Lever	

5. Timing Advance Specification :

Pump Speed (r.p.m)	Below 1,650	1,600	1,800	1,900		
Advance Angle (deg.)	Start	Below 0.6	2.5~3.5	4~5	Finish (5)	

3. GOVERNOR ADJUSTMENT

101491-0032 2/4

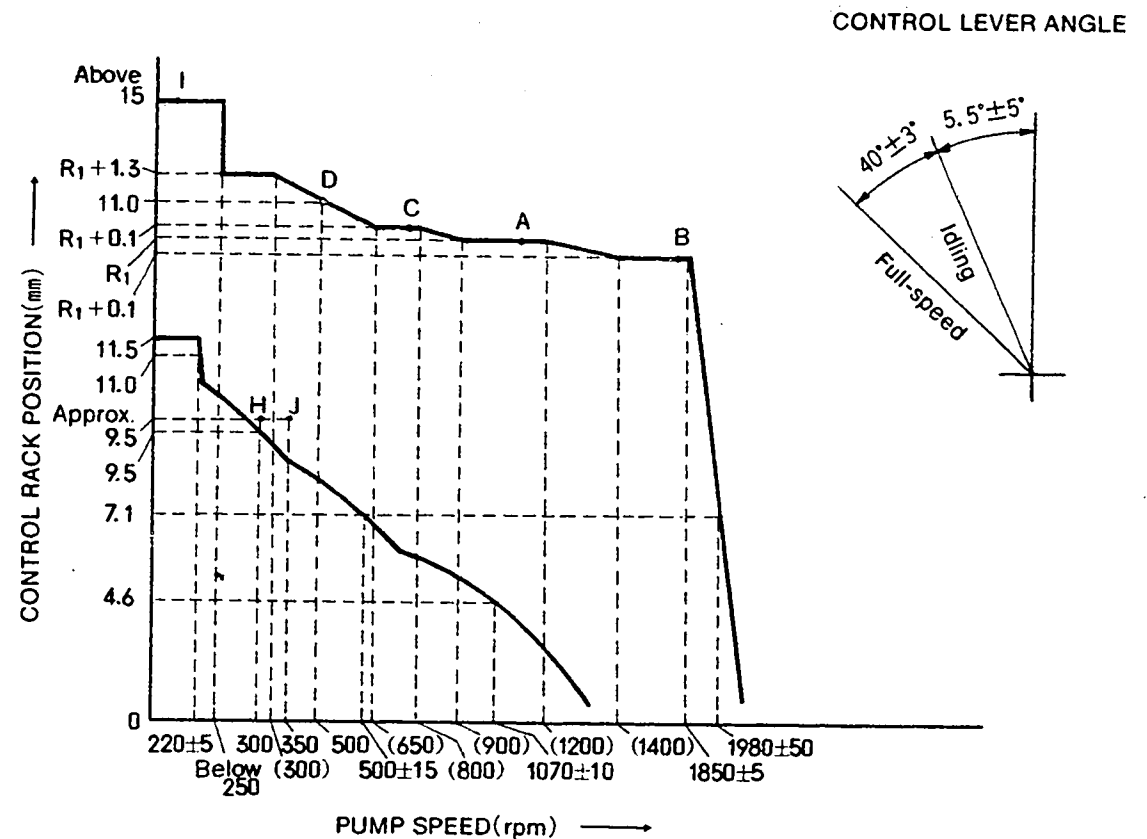

■ Idling Adjustment

Item	Pump Speed (rpm)	Rack Position (mm)	Remarks
Idling Lever Position: Temporary Setting	80~100	11.5	• Adjust using screw ①.
Idling Position Setting	300	9.5	• Adjust using spring capsule ①.
	215~225	11.0	• Adjust using screw ②.
Governor Spring Contact Adjustment	485~515	7.1	• Adjust the governor shaft position.
	1000~1140	4.6	• Confirm
Setting the Idling Lever Position	300	Approx.9.5	• Adjust using screw ①.
	—	—	• Confirm the control lever angle (0.5°~10.5°)

Full Load Adjustment (Torque Cam No. 55)

Item	Pump Speed (rpm)	Rack Position (mm)	Remarks
Full Speed Lever Position: Temporary Setting	Approx. 1850	(10.2) - 0.1	• Adjust using screw ③. (Do not enter governor control range)
Full Load Position Adjustment	1100	(10.2)	• Adjust using screw ④.
Torque Cam Position Adjustment	500	11.0	• Adjust using screw ⑤.
	(300)	(10.2) + 1.3	• Confirm
	(650)	(10.2) + 0.1	• "
	(800)	(10.2) + 0.1	• "
	(900)	(10.2)	• "
	(1200)	(10.2)	• "
	(1400)	((0.2) - 0.1	• "
	—	—	• "
Confirm injection quantity at points A to D.			
Maximum Speed control Adjustment	1845~1855	(10.2) - 0.1	• Adjust using screw ③.
	1930~2030	7.1	• Confirm • After adjustment, confirm that the control lever angle is 37°~43°
Confirming Excess Fuel Limit for Engine Starting	350	Approx. 9.5	• Set the control lever at point J.
	0	11.5	• Confirm
	0	Above 15	• Move the control lever to the "full-speed" position and then confirm the control rack position.
Confirm the Black Smoke Limit	Fix the control lever at point H. Then, operate the pump at 270 rpm. Confirm that the control rack does not move beyond (10.2) + 1.3 mm. When the control lever is moved to the "full-speed" position again increase the pump speed and confirm that the control rack starts to move from a pump speed of 300 rpm.		
Rack Limiter Adjustment	0	Above 15	• Fix the control rack using screw Part No. 157954-3700
	Measure the depth of the control rack cap. Then, adjust screw ⑥ so that it equals the depth of the rack cap and install the rack cap. Confirm injection quantity at point i.		

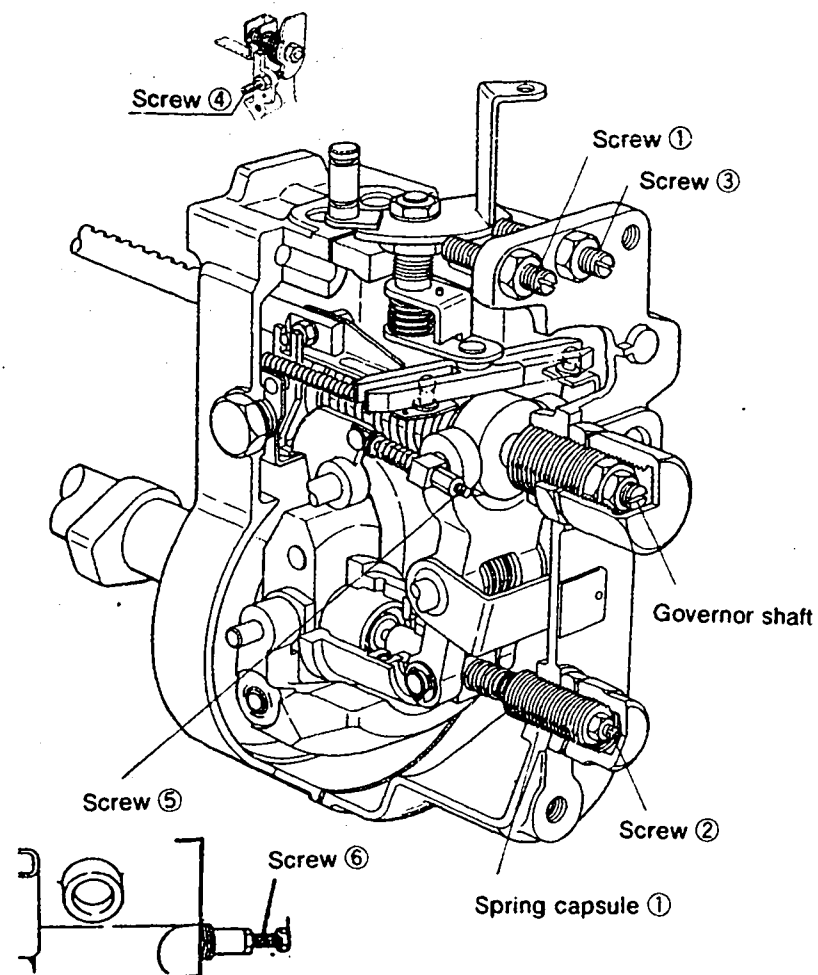
Timing Setting

At No. 1 plunger's beginning of injection position.
B.D.T.C : 15°

Pump center line

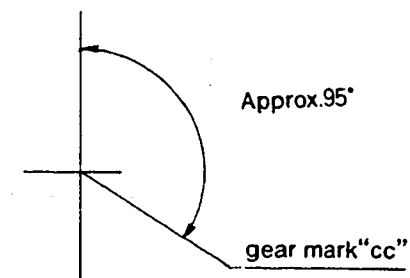

INJ. PUMP CALIBRATION DATA

ENGINE MODEL 4BC2

BOSCH No.9 400 610 021

DKKC No. 101491-0161

Date: 20.Nov.1986

Company: ISUZU

No. 5-15601-371-1

Injection pump : PES4A
101049-8150

Governor : EP/RLD
105931-0980

Timing device : EP/SCD
105622-0861

1. Test Conditions :

Pump rotation : clockwise viewed from drive side

Nozzle & Nozzle Holder Ass'y : 105780-0000 (BOSCH Type No.DN12SD12)
Nozzle Holder : 105780-2080 (BOSCH Type No.EF8511/9A)
Nozzle opening pressure : 175 Kg/cm²
Transfer pump pressure : 1.6 Kg/cm²

Injection pipe : Inner Dia. 2 mm X Outer Dia. 6 mm - Length 600 mm

Test Oil : ISO4113 or SAE Standard Test Oil (SAE J967d) Oil Temp. : 40^{±5} °C

Overflow valve opening pressure : Kg/cm²

2. Injection Timing :

Pre-stroke : No. 1 Plunger 3.4 ±0.05mm

Note : Adjust with control rod position of 10.2 mm

Injection order : 1 ~ 3 ~ 4 ~ 2 (interval : 90° ±30')

Plungers are numbered from the Drive side.

Tappet clearance : Bolt adjustment type ; More than 0.3mm for all cylinders.
Shim adjustment type ; Manually rotate the camshaft 2~3 times and confirm that it rotates smoothly.

4. Injection Quantity :

Adjusting Point	Rod Position (mm)	Pump Speed (r.p.m)	Injection Q'ty (cc/1000 strokes)	Max. var bet. cyl (%)	Fixed	Remarks
	10.2	1,100	49.4 ~ 52.6	±2.5	Rack	Basic
H	Approx. 9.8	300	8.0 ~ 11.0	±14	Rack	
A	R.(10.2)	1,100	50.0 ~ 52.0	—	Lever	Basic
B	R-0.1	1,800	47.6 ~ 50.8	—	Lever	
C	R+0.1	700	38.4 ~ 41.6	—	Lever	
D	R+0.8	500	40.1 ~ 44.1	—	Lever	
I	Above 15	100	65.0 ~ 81.0	—	Lever	

5. Timing Advance Specification :

Pump Speed (r.p.m)	Below 1,650	1,600	1,800	1,900		
Advance Angle (deg.)	Start	Below 0.6	2.5~3.5	4~5	Finish (5)	

3. GOVERNOR ADJUSTMENT

101491-0161 2/4

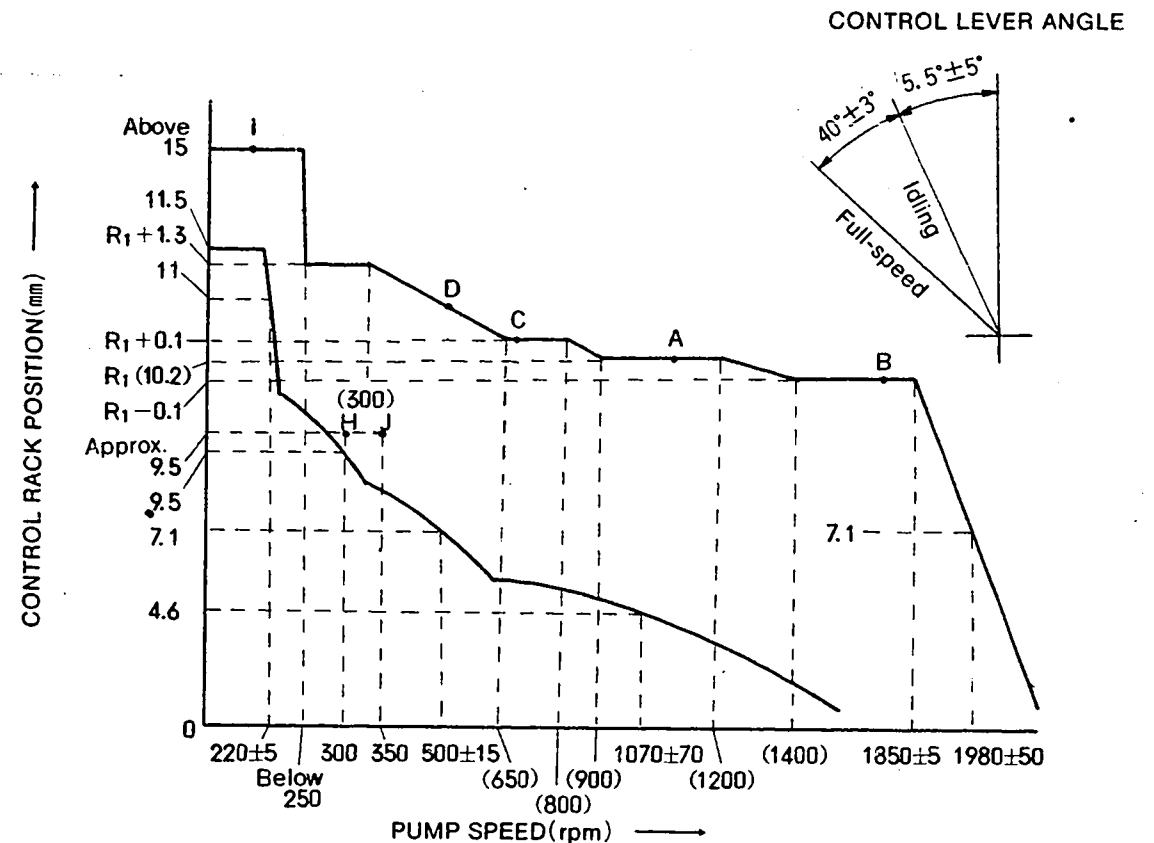

■ Idling Adjustment

Item	Pump Speed (rpm)	Rack Position (mm)	Remarks
Idling Lever Position: Temporary Setting	80~100	11.5	• Adjust using screw ①.
Idling Position Setting	300	9.5	• Adjust using spring capsule ①.
	215~225	11	• Adjust using screw ②.
Governor Spring Contact Adjustment	485~515	7.1	• Adjust the governor shaft position.
	1000~1140	4.6	• Confirm
Setting the Idling Lever Position	300	Approx.9.5	• Adjust using screw ①.
	—	—	• Confirm the control lever angle (0.5°~10.5°)

■ Full Load Adjustment (Torque Cam No. 55)

Item	Pump Speed (rpm)	Rack Position (mm)	Remarks
Full Speed Lever Position: Temporary Setting	1800	(10.2) - 0.1	• Adjust using screw ③. (Do not enter governor control range)
Full Load Position Adjustment	1100	(10.2)	• Adjust using screw ④.
Torque Cam Position Adjustment	500	(10.2) + 0.8	• Adjust using screw ⑤.
	(300)	(10.2) + 1.3	• Confirm
	(650)	(10.2) + 0.1	• "
	(800)	(10.2) + 0.1	• "
	(900)	(10.2)	• "
	(1200)	(10.2)	• "
	(1400)	(10.2) - 0.1	• "
	—	—	• "
Confirm injection quantity at points A to E.			
Maximum Speed control Adjustment	1845~1855	(10.2) - 0.1	• Adjust using screw ③.
	1930~2030	7.1	• Confirm • After adjustment, confirm that the control lever angle is 37°~43°
Confirming Excess Fuel Limit for Engine Starting	350	Approx. 9.5	• Set the control lever at point J.
	0	11.5	• Confirm
	0	Above 15	• Move the control lever to the "full-speed" position and then confirm the control rack position.
Confirm the Black Smoke Limit	Fix the control lever at point H. Then, operate the pump at 250 rpm. Confirm that the control rack does not move beyond (10.2) + 1.3 mm. When the control lever is moved to the "full-speed" position again increase the pump speed and confirm that the control rack starts to move from a pump speed of (300) rpm.		
Rack Limiter Adjustment	—	—	• Fix the control rack using screw Part No. —
	Measure the depth of the control rack cap. Then, adjust screw ⑥ so that it equals the depth of the rack cap and install the rack cap. Confirm injection quantity at point I.		

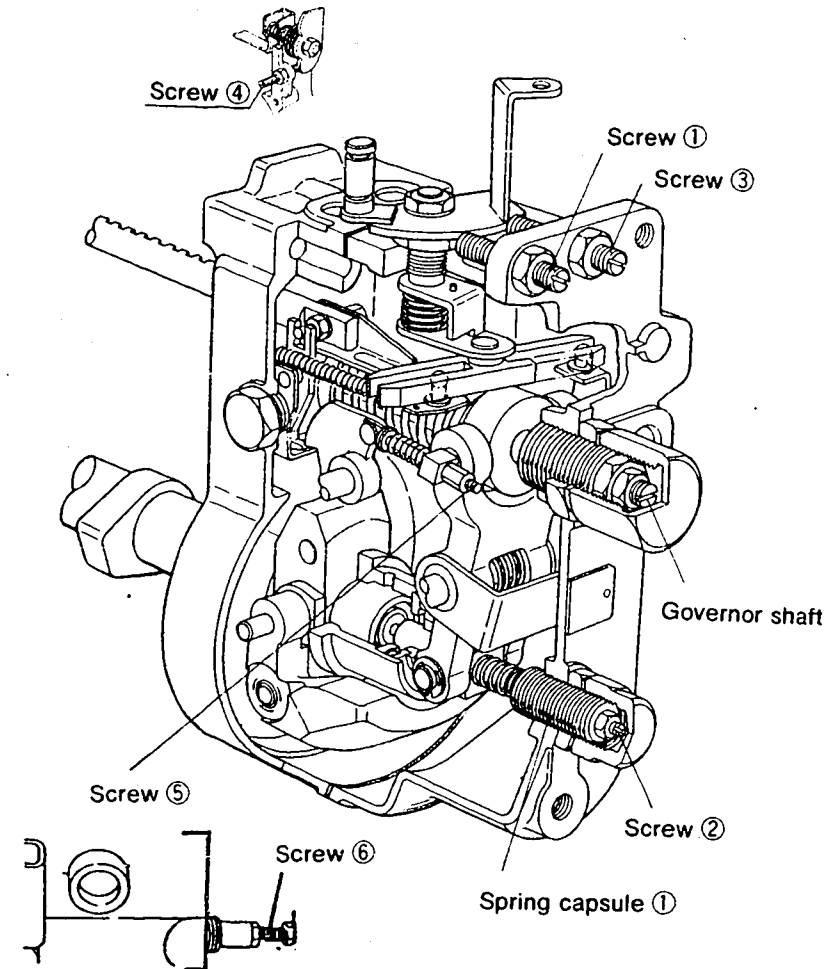

■ Timing Setting

At No. 1 plunger's beginning of injection position.
B.D.T.C. : 15°

Pump center line

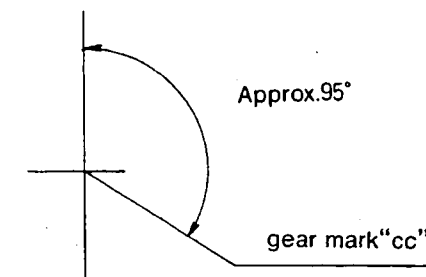

INJ. PUMP CALIBRATION DATA

ENGINE MODEL 4BC2

BOSCH No.9 400 610 015
 DKKC No. 101491-0262
 Date: 20.Nov.1986 [1]
 Company: ISUZU
 No. 8-94139-019-2

Injection pump : PES4A 101049-8240 Governor : EP/RLD 105931-2092 Timing device : EP/SCD 105622-1220

1. Test Conditions :

Pump rotation : clockwiseviewed from drive side
 Nozzle & Nozzle Holder Ass'y : 105780-0000 (BOSCH Type No.DN12SD12) Nozzle Holder : 105780-2080 (BOSCH Type No.EF8511/9A)
 Nozzle opening pressure : 175 Kg/cm² Transfer pump pressure : 1.6 Kg/cm²
 Injection pipe : Inner Dia. 2 mm X Outer Dia. 6 mm - Length 600 mm
 Test Oil : ISO4113 or SAE Standard Test Oil (SAE J967d) Oil Temp. : 40⁺⁵ °C
 Overflow valve opening pressure : Kg/cm²

2. Injection Timing :

Pre-stroke : No. 1 Plunger 3.4 ±0.05mm
 Note : Adjust with control rod position of 10.2 mm
 Injection order : 1 ~ 3 ~ 4 ~ 2 (interval : 90° ±30')

Plungers are numbered from the Drive side.

Tappet clearance : Bolt adjustment type ; More than 0.3mm for all cylinders.
 Shim adjustment type ; Manually rotate the camshaft 2~3 times and confirm that it rotates smoothly.

4. Injection Quantity :

Adjusting Point	Rod Position (mm)	Pump Speed (r.p.m)	Injection Q'ty (cc/1000 strokes)	Max. var bet. cyl (%)	Fixed	Remarks
	10.2	1,100	49.4 ~ 52.6	±2.5	Rack	Basic
H	Approx. 9.8	300	8.0 ~ 11.0	±14	Rack	
A	R ₁ (10.2)	1,100	50.0 ~ 52.0	-	Lever	Basic
B	R ₁ -0.1	1,800	47.6 ~ 50.8	-	Lever	
C	R ₁ +0.1	700	38.4 ~ 41.6	-	Lever	
I	Above 15	100	65.0 ~ 81.0	-	Lever	

5. Timing Advance Specification :

Pump Speed (r.p.m)	1,650	1,600	1,800	1,900		
Advance Angle (deg.)	Start	Below 0.6	2.5~3.5	4~5	Finish (5)	

3. GOVERNOR ADJUSTMENT

101491-0262 2/4

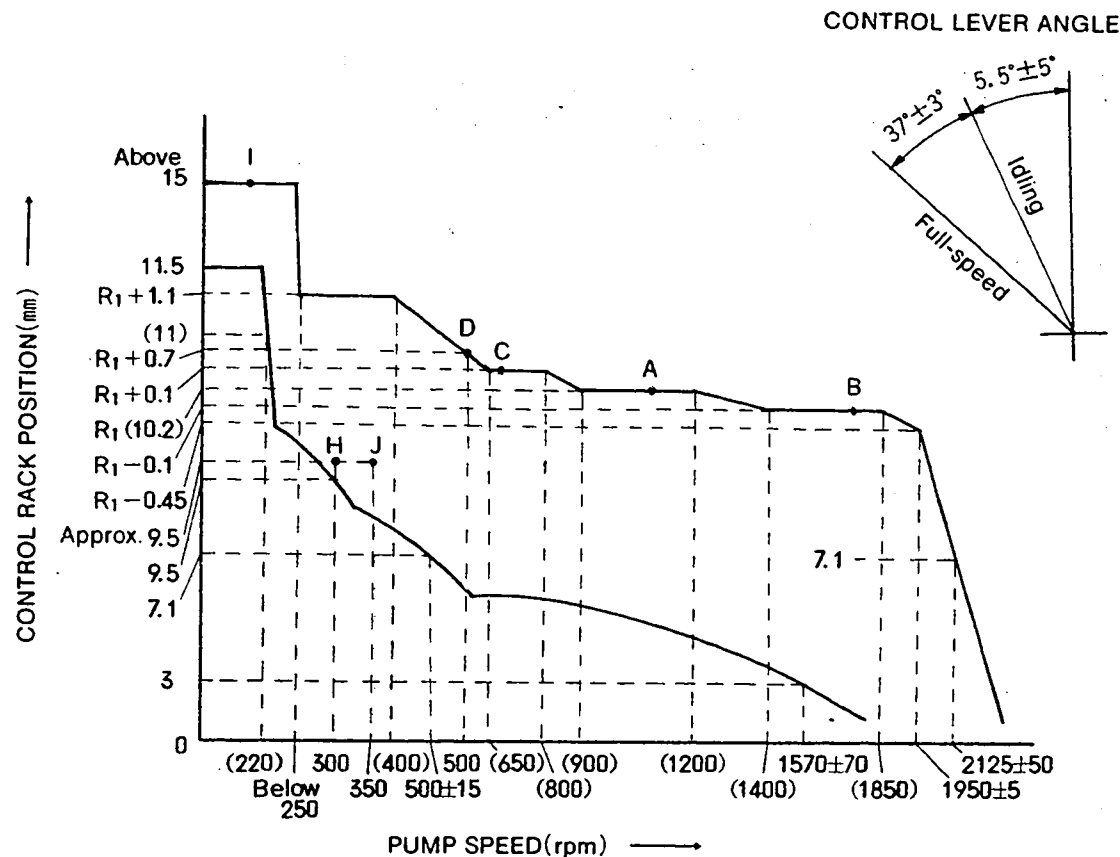

Idling Adjustment

Item	Pump Speed (rpm)	Rack Position (mm)	Remarks
Idling Lever Position: Temporary Setting	80~100	11.5	• Adjust using screw ①.
Idling Position Setting	300 (220)	9.5 (11)	• Adjust using spring capsule ①. • Adjust using screw ②.
Governor Spring Contact Adjustment	485~515 1500~1640	7.1 3	• Adjust the governor shaft position. • Confirm
Setting the Idling Lever Position	300	Approx.9.5	• Adjust using screw ①. • Confirm the control lever angle (0.5°~10.5°)

■ Full Load Adjustment (Torque Cam No. A49)

Item	Pump Speed (rpm)	Rack Position (mm)	Remarks
Full Speed Lever Position: Temporary Setting	Approx.1950	(10.2)-0.45	• Adjust using screw ③. (Do not enter governor control range)
Full Load Position Adjustment	1100	(10.2)	• Adjust using screw ④.
Torque Cam Position Adjustment	500	(10.2)+0.7	• Adjust using screw ⑤.
	(400)	(10.2)+1.1	• Confirm
	(650)	(10.2)+0.1	• "
	(800)	(10.2)+0.1	• "
	(900)	(10.2)	• "
	(1200)	(10.2)	• "
	(1400)	(10.2)-0.1	• "
	(1850)	(10.2)-0.1	• "
Confirm injection quantity at points A to E.			
Maximum Speed control Adjustment	1945~1955	(10.2)-0.45	• Adjust using screw ③.
	2075~2175	7.1	• Confirm • After adjustment, confirm that the control lever angle is 34°~40°
Confirming Excess Fuel Limit for Engine Starting	350	Approx.9.5	• Set the control lever at point J.
	0	11.5	• Confirm
	0	Above 15	• Move the control lever to the "full-speed" position and then confirm the control rack position.
Confirm the Black Smoke Limit	Fix the control lever at point H. Then, operate the pump at 250 rpm. Confirm that the control rack does not move beyond (10.2)+1.1 mm. When the control lever is moved to the "full-speed" position again increase the pump speed and confirm that the control rack starts to move from a pump speed of (400) rpm.		
Rack Limiter Adjustment	—	—	• Fix the control rack using screw
	Measure the depth of the control rack cap. Then, adjust screw ⑥ so that it equals the depth of the rack cap and install the rack cap. Confirm injection quantity at point I.		

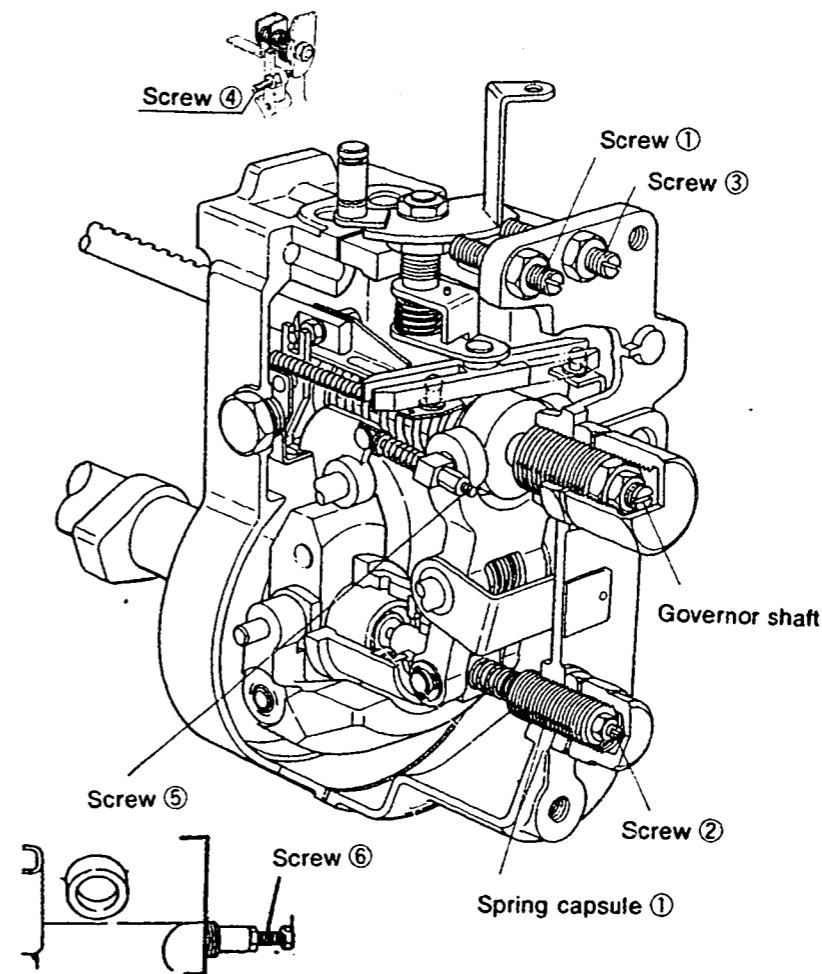

■ Timing Setting

At No. 1 plunger's beginning of injection position.
B.D.T.C. : 15°

Pump center line

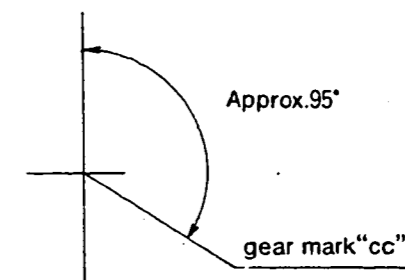

INJ. PUMP CALIBRATION DATA

ENGINE MODEL 4BC2

BOSCH No. 9 400 610 016
 DKKC No. 101491-0272
 Date: 20.Nov.1986 (3)
 Company: ISUZU
 No. 8-94139-134-2

Injection pump : PES4A Governor : EP/RLD Timing device : EP/SCD
 101049-8240 105931-2132 105622-1220

1. Test Conditions :

Pump rotation : clockwise viewed from drive side

Nozzle & Nozzle Holder Ass'y : 105780-0000 (BOSCH Type No. DN12SD12) Nozzle Holder : 105780-2080 (BOSCH Type No. EF8511/9A)
 Nozzle opening pressure : 175 Kg/cm² Transfer pump pressure : 1.6 Kg/cm²

Injection pipe : Inner Dia. 2 mm X Outer Dia. 6 mm - Length 600 mm

Test Oil : ISO4113 or SAE Standard Test Oil (SAE J967d) Oil Temp. : 40^{±5} °C

Overflow valve opening pressure : Kg/cm²

2. Injection Timing :

Pre-stroke : No. 1 Plunger 3.4 ±0.05mm
 Note : Adjust with control rod position of 10.2 mm

Injection order : 1 ~ 3 ~ 4 ~ 2 (interval : 90° ±30°)
 Plungers are numbered from the Drive side.

Tappet clearance : Bolt adjustment type : More than 0.3mm for all cylinders.
 Shim adjustment type : Manually rotate the camshaft 2~3 times and confirm that it rotates smoothly.

4. Injection Quantity :

Adjusting Point	Rod Position (mm)	Pump Speed (r.p.m)	Injection Q'ty (cc/1000 strokes)	Max. var bet. cyl (%)	Fixed	Remarks
	10.2	1,100	49.4 ~ 52.6	±2.5	Rack	Basic
H	Approx. 9.8	300	8.0 ~ 11.0	±14	Rack	
A	R(10.2)	1,100	50.0 ~ 52.0	-	Lever	Basic
B	R-0.1	1,800	47.6 ~ 50.8	-	Lever	
C	R+0.1	700	38.4 ~ 41.6	-	Lever	
I	Above 15	100	65.0 ~ 81.0	-	Lever	

5. Timing Advance Specification :

Pump Speed (r.p.m)	1,650	1,600	1,800	1,900		
Advance Angle (deg.)	Start	Below 0.6	2.5~3.5	4~5	Finish (5)	

3. GOVERNOR ADJUSTMENT

101491-0272 2/5

CONTROL LEVER ANGLE

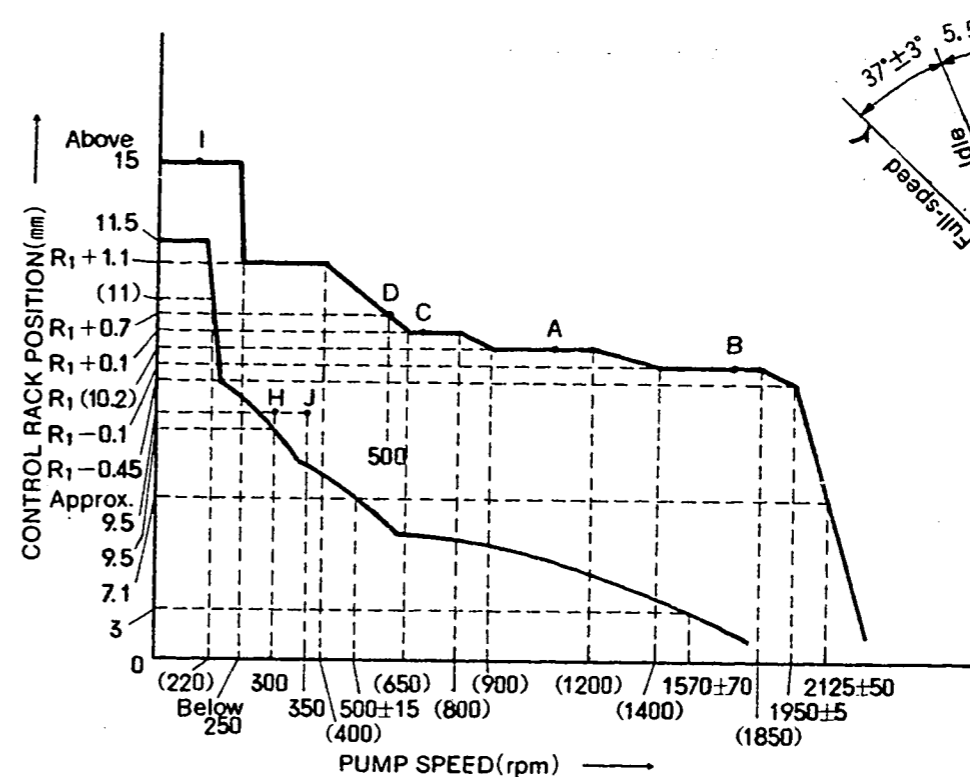

Idling Adjustment

Item	Pump Speed (rpm)	Rack Position (mm)	Remarks
Idling Lever Position: Temporary Setting	80~100	11.5	• Adjust using screw ①.
Idling Position Setting	300 (220)	9.5 (11)	• Adjust using spring capsule ①. • Adjust shim inside the spring capsule.
Governor Spring Contact Adjustment	485~515	7.1	• Adjust the governor shaft position.
	1500~1640	3	• Confirm
Setting the Idling Lever Position	300	Approx. 9.5	• Adjust using screw ①.
	—	—	• Confirm the control lever angle (0.5°~10.5°)

■ Full Load Adjustment (Torque Cam No. A49)

Item	Pump Speed (rpm)	Rack Position (mm)	Remarks
Full Speed Lever Position: Temporary Setting	Approx.1900	(10.2)-0.45	• Adjust using screw ③. (Do not enter governor control range)
Full Load Position Adjustment	1100	(10.2)	• Adjust using screw ④.
Torque Cam Position Adjustment	500	(10.2)+0.7	• Adjust using screw ⑤.
	(400)	(10.2)+1.1	• Confirm
	(650)	(10.2)+0.1	• "
	(800)	(10.2)+0.1	• "
	(900)	(10.2)	• "
	(1200)	(10.2)	• "
	(1400)	(10.2)-0.1	• "
	(1850)	(10.2)-0.1	• "
	—	—	• "
Confirm injection quantity at points A to C.			
Maximum Speed control Adjustment	1900~2000	(10.2)-0.45	• Adjust using screw ③.
	2075~2175	7.1	• Confirm • After adjustment, confirm that the control lever angle is 34°~40°
Confirming Excess Fuel Limit for Engine Starting	350	Approx.9.5	• Set the control lever at point J .
	0	11.5	• Confirm
	0	Above 15	• Move the control lever to the "full-speed" position and then confirm the control rack position.
Confirm the Black Smoke Limit	Fix the control lever at point H. Then, operate the pump at 250 rpm. Confirm that the control rack does not move beyond (10.2)+1.1 mm. When the control lever is moved to the "full-speed" position again increase the pump speed and confirm that the control rack starts to move from a pump speed of (400) rpm.		
Rack Limiter Adjustment	—	—	• Fix the control rack using screw
	Measure the depth of the control rack cap. Then, adjust screw ⑥ so that it equals the depth of the rack cap and install the rack cap. Confirm injection quantity at point I .		

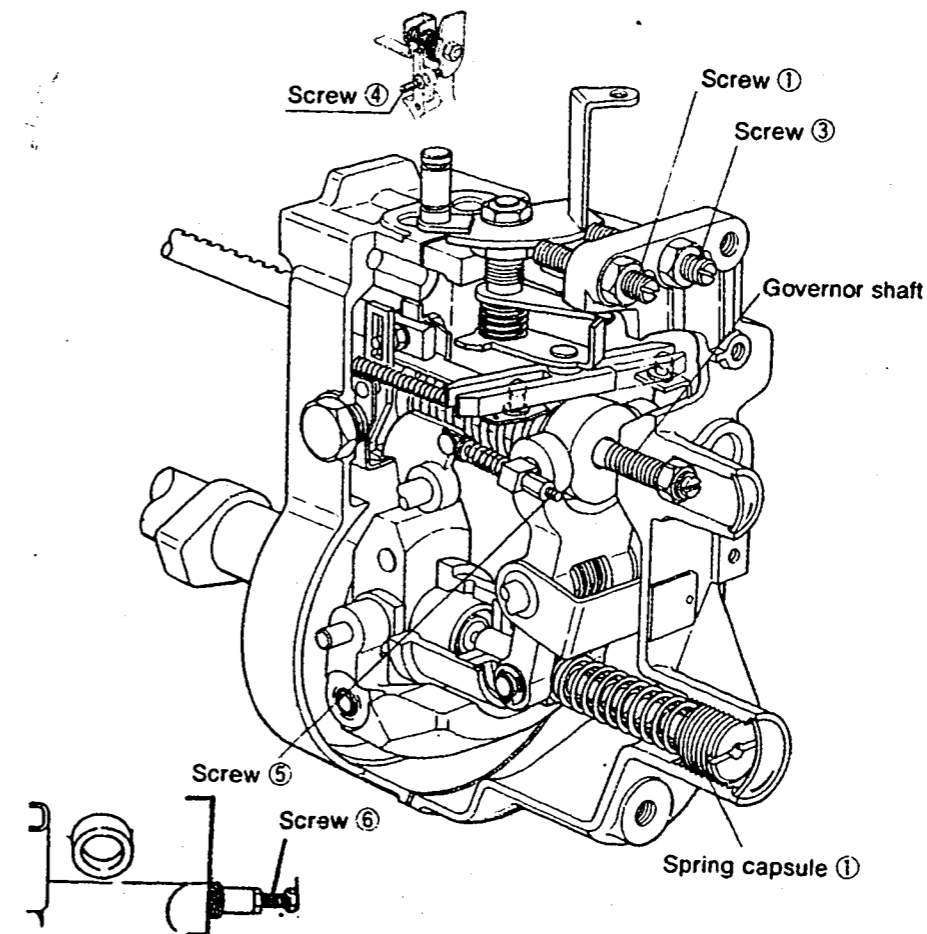

■ Timing Setting

At No. 1 plunger's beginning of injection position.
B.D.T.C. : 15°

Pump center line

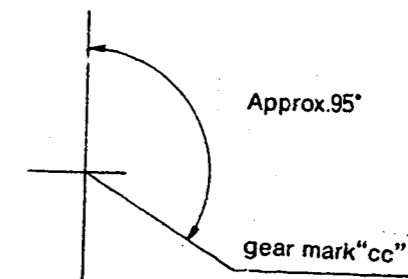

101491-0272 5/5

■ Aneroid Compensator Adjustment

1) Test Condition

- Control lever position: Full speed position
- Pump speed: 1100 rpm.

2) Aneroid Compensator Kit Adjustment (Before installation of ASC)

- Adjust screw ⑦ so that the clearance between the housing and the snapping is 1.4~1.7 mm.
 - Check that the protrusion of the pushrod from the spacer is 0~1.0 mm.
- If not as specified, replace the pushrod.

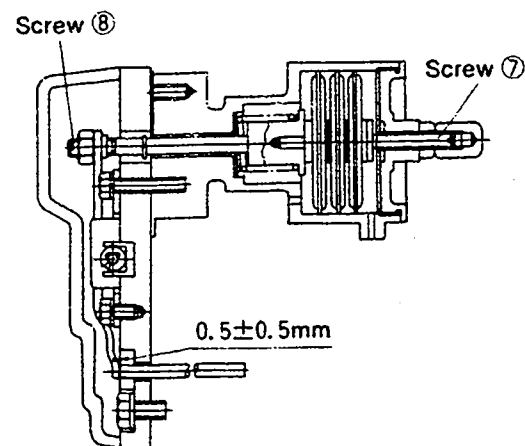

3) Aneroid Compensator Kit Adjustment (After installation of ASC)

- Supply negative pressure of 165 mmHg to the ASC chamber and adjust the rack position using screw ⑧.
- Supply negative pressure of 10~50 mmHg to the ASC chamber and confirm that the rack position is 10.2 mm. Then, confirm that a fuel injection quantity of 50~52 cc/1000 st is obtained.

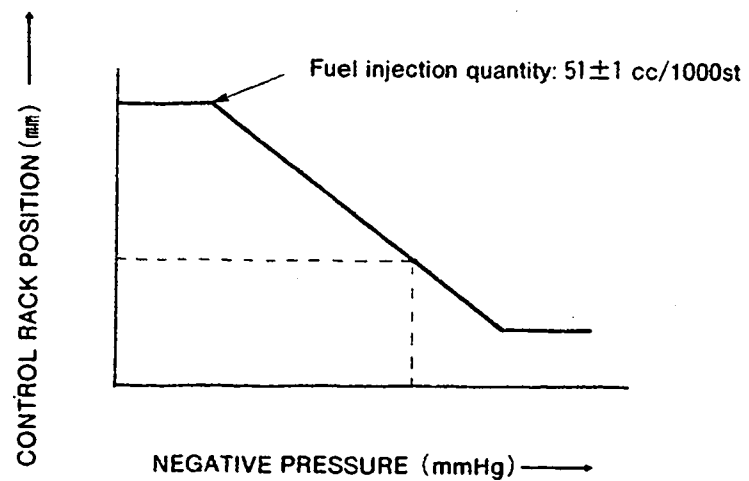

INJ. PUMP CALIBRATION DATA

ENGINE MODEL SL

BOSCH No.9 400 610 017
 DKKC No. 101491-9083
 Date : 20.Nov.1986 [4]
 Company : MAZDA
 No. SL09 13 800C

Injection pump : PES4A Governor : EP/RLD Timing device : EP/SCDM
 101049-9121 105921-0721 105670-0080

1. Test Conditions :

Pump rotation : clockwise viewed from drive side
 Nozzle & Nozzle Holder Ass'y : 105780-0000 (BOSCH Type No.DN12SD12)
 Nozzle Holder : 105780-2080 (BOSCH Type No.EF8511/9A)
 Nozzle opening pressure : 175 Kg/cm² Transfer pump pressure : 1.6 Kg/cm²
 Injection pipe : Inner Dia. 2 mm X Outer Dia. 6 mm - Length 600 mm
 Test Oil : ISO4113 or SAE Standard Test Oil (SAE J967d) Oil Temp. : 40^{±5} °C
 Overflow valve opening pressure : Kg/cm²

2. Injection Timing :

Pre-stroke : No. 1 Plunger 3.4 ±0.05mm
 Note : Adjust with control rod position of mm
 Injection order : 1 ~ 3 ~ 4 ~ 2 (interval : 90° ±30')

Plungers are numbered from the Drive side.

Tappet clearance : Bolt adjustment type ; More than 0.3mm for all cylinders.
 Shim adjustment type ; Manually rotate the camshaft 2~3 times and confirm that it rotates smoothly.

4. Injection Quantity :

Adjusting Point	Rod Position (mm)	Pump Speed (r.p.m)	Injection Q'ty (cc/1000 strokes)	Max. var bet. cyl (%)	Fixed	Remarks
	11.21±0.02	1,000	56.3 ~ 57.3	±2.5	Rack	Basic
H	Approx. 9.3	325	7.0 ~ 11.0	±14	Rack	
A	(11.21)	1,000	56.3 ~ 57.3	-	Lever	Basic
B	(11.48)	1,700	66.9 ~ 70.9	-	Lever	
C	(11.32)	625	40.0 ~ 44.0	-	Lever	
I	Above 15	100	96.0 ~ 116.0	-	Lever	

5. Timing Advance Specification :

Pump Speed (r.p.m)	1,325~1,370	1,700				
Advance Angle (deg.)	Start	Finish	3.2~3.8			

3. GOVERNOR ADJUSTMENT

101491-9083 2/4

CONTROL LEVER ANGLE

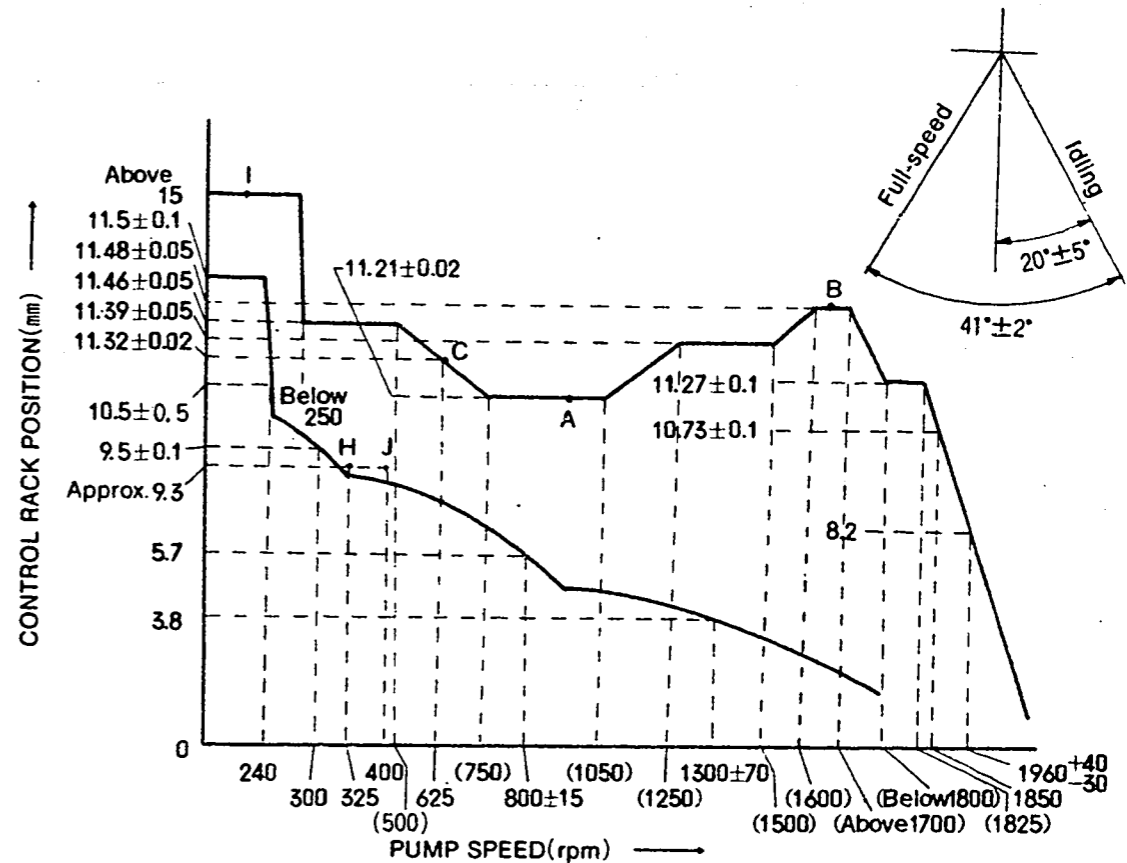

Idling Adjustment

Item	Pump Speed (rpm)	Rack Position (mm)	Remarks
Idling Lever Position: Temporary Setting	80~100	11.4~11.6	• Adjust using screw ①.
Idling Position Setting	300	9.4~9.6	• Adjust using spring capsule ①.
	240	10.0~11.0	• Adjust using screw ②.
Governor Spring Contact Adjustment	785~815	5.7	• Adjust the governor shaft position.
	1230~1370	3.8	• Confirm
Setting the Idling Lever Position	325	Approx.9.3	• Adjust using screw ①.
	—	—	• Confirm the control lever angle (15°~25°)

101491-9083 3/4

■ Full Load Adjustment (Torque Cam No. A19)

Item	Pump Speed (rpm)	Rack Position (mm)	Remarks
Full Speed Lever Position: Temporary Setting	Approx.1800	Approx.11.27	• Adjust using screw ③. (Do not enter governor control range)
Full Load Position Adjustment	1000	11.19~11.23	• Adjust using screw ④.
Torque Cam Position Adjustment	625	11.31~11.34	• Adjust using screw ⑤.
	450	11.41~11.51	• Confirm
	1400	11.34~11.44	• "
	1700	11.43~11.53	• "
	1800	11.17~11.37	• "
	—	—	• "
	—	—	• "
Confirm injection quantity at points A to C.			
Maximum Speed control Adjustment	1850	10.63~10.83	• Adjust using screw ③.
	1930~2000	8.2	• Confirm
	—	—	• After adjustment, confirm that the control lever angle is 38°~44°
Confirming Excess Fuel Limit for Engine Starting	400	Approx.9.3	• Set the control lever at point J .
	0	11.4~11.6	• Confirm
	0	Above 15	• Move the control lever to the "full-speed" position and then confirm the control rack position.
Confirm the Black Smoke Limit	Fix the control lever at point H. Then, operate the pump at 250 rpm. Confirm that the control rack does not move beyond 11.46 mm. When the control lever is moved to the "full-speed" position again increase the pump speed and confirm that the control rack starts to move from a pump speed of (500) rpm.		
Rack Limiter Adjustment	—	—	• Fix the control rack using screw Part No. 157954-3700
	Measure the depth of the control rack cap. Then, adjust screw ⑥ so that it equals the depth of the rack cap and install the rack cap. Confirm injection quantity at point I .		

101491-9083 4/4

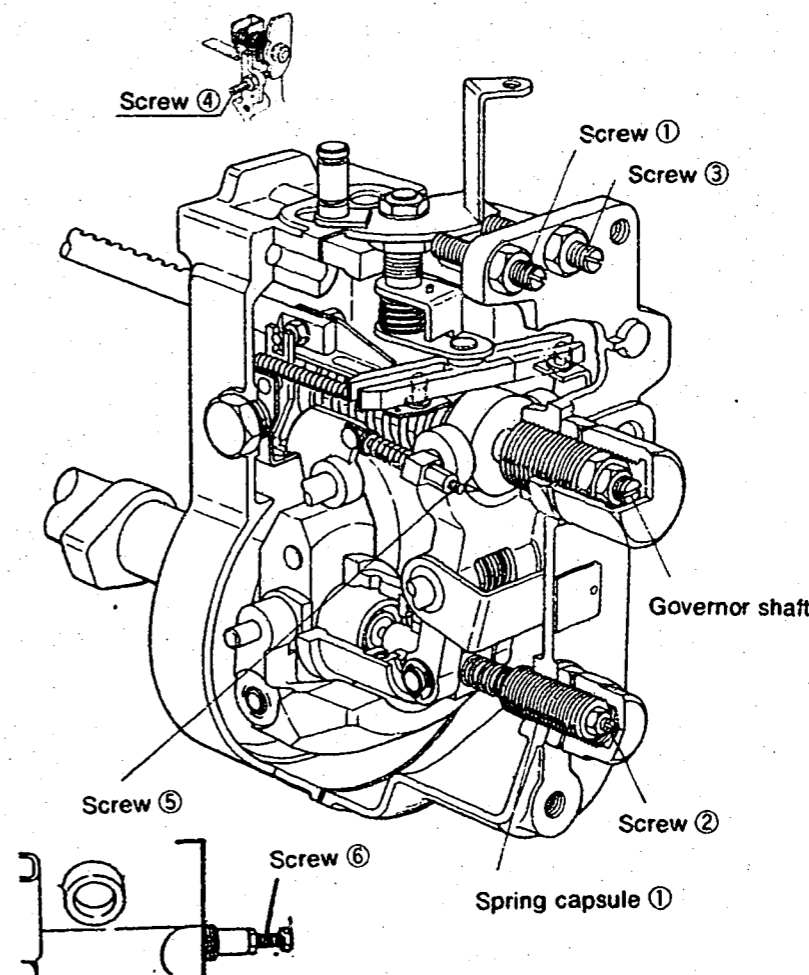

■ Timing Setting

At No. 1 plunger's beginning of injection position.
B.D.T.C. : 12°

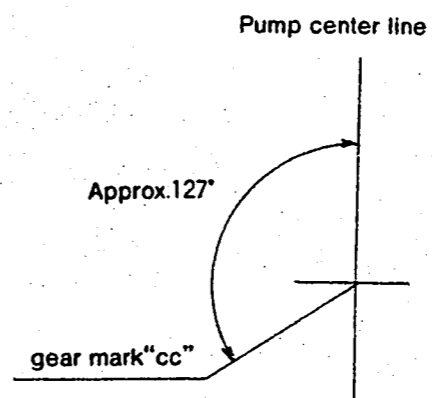

INJ. PUMP CALIBRATION DATA

ENGINE MODEL SL

BOSCH No.9 400 610 051
 DKKC No. 101491-9084
 Date: 20.Nov.1986 [4]
 Company: MAZDA
 No. SL09 13 800D

Injection pump : PES4A Governor : EP/RLD Timing device : EP/SCDM
 101049-9180 105921-1220 105670-0080

1. Test Conditions :

Pump rotation : clockwise viewed from drive side

Nozzle & Nozzle Holder Ass'y : 105780-0000 (BOSCH Type No.DN12SD12)
 Nozzle Holder : 105780-2080 (BOSCH Type No.EF8511/9A)

Nozzle opening pressure : 175 Kg/cm²
 Transfer pump pressure : 1.6 Kg/cm²

Injection pipe :
 Inner Dia. 2 mm X Outer Dia. 6 mm - Length 600 mm

Test Oil : ISO4113 or SAE Standard Test Oil (SAE J967d) Oil Temp. : 40^{±5} °C

Overflow valve opening pressure : Kg/cm²

2. Injection Timing :

Pre-stroke : No. 1 Plunger 3.4 ±0.05mm
 Note : Adjust with control rod position of mm

Injection order : 1 ~ 3 ~ 4 ~ 2 (interval : 90° ±30°)

Plungers are numbered from the Drive side.

Tappet clearance : Bolt adjustment type : More than 0.3mm for all cylinders.
 Shim adjustment type : Manually rotate the camshaft 2~3 times and confirm that it rotates smoothly.

4. Injection Quantity :

Adjusting Point	Rod Position (mm)	Pump Speed (r.p.m)	Injection Q'ty (cc/1000 strokes)	Max. var bet. cyl (%)	Fixed	Remarks
	11.21±0.02	1,000	56.3 ~ 57.3	±2.5	Rack	Basic
H	Approx. 9.3	325	7.0 ~ 11.0	±14	Rack	
A	(11.21)	1,000	56.3 ~ 57.3	-	Lever	Basic
B	(11.48)	1,700	56.9 ~ 70.9	-	Lever	
C	(11.32)	625	40.0 ~ 44.0	-	Lever	
I	Above 15	100	96.0 ~ 116.0	-	Lever	

5. Timing Advance Specification :

Pump Speed (r.p.m)	1,325~1,370	1,700				
Advance Angle (deg.)	Start	Finish 3.2~3.8				

3. GOVERNOR ADJUSTMENT

101491-9084 2/4

CONTROL LEVER ANGLE

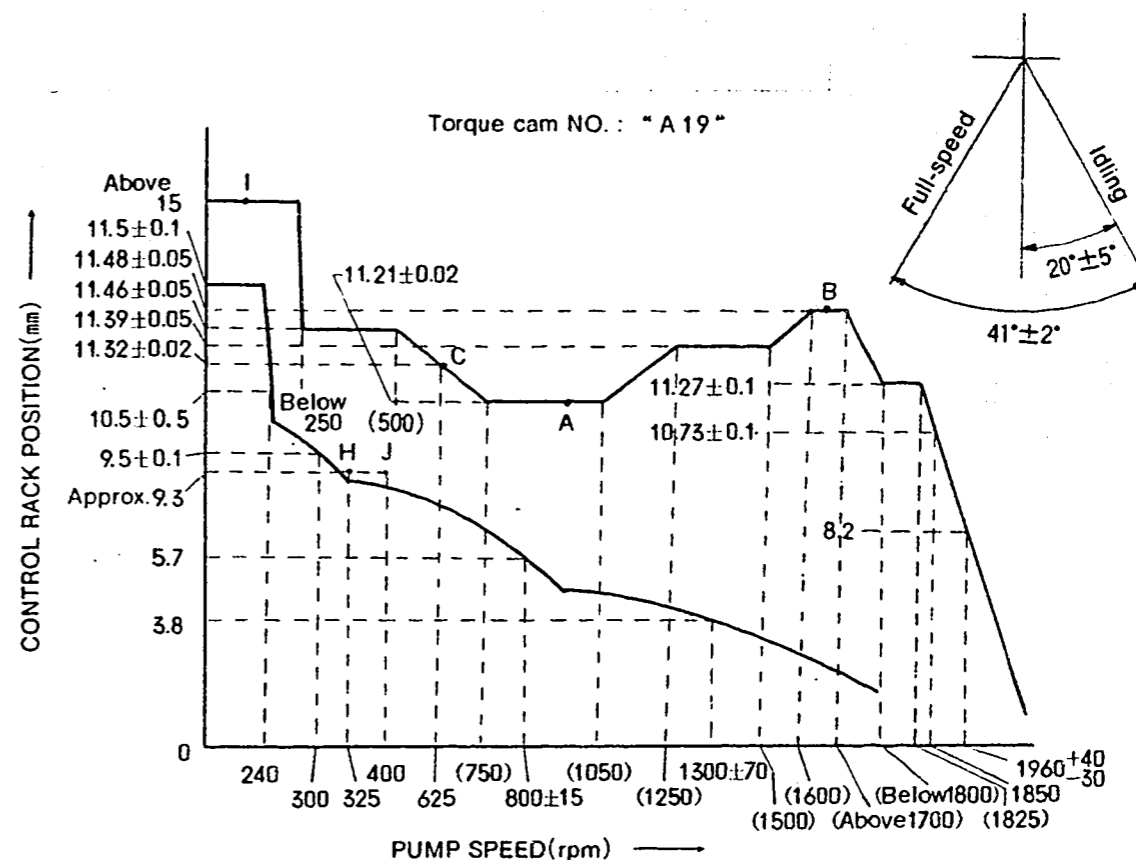

Idling Adjustment

Item	Pump Speed (rpm)	Rack Position (mm)	Remarks
Idling Lever Position: Temporary Setting	80~100	11.4~11.6	• Adjust using screw ①.
Idling Position Setting	300	9.4~9.6	• Adjust using spring capsule ①.
	240	10.0~11.0	• Adjust using screw ②.
Governor Spring Contact Adjustment	785~815	5.7	• Adjust the governor shaft position.
	1230~1370	3.8	• Confirm
Setting the Idling Lever Position	325	Approx.9.3	• Adjust using screw ①.
	---	---	• Confirm the control lever angle (15°~25°)

■ Full Load Adjustment (Torque Cam No. A19)

Item	Pump Speed (rpm)	Rack Position (mm)	Remarks
Full Speed Lever Position: Temporary Setting	Approx.1800	Approx.11.27	• Adjust using screw ③. (Do not enter governor control range)
Full Load Position Adjustment	1000	11.19~11.23	• Adjust using screw ④.
Torque Cam Position Adjustment	625	11.31~11.34	• Adjust using screw ⑤.
	450	11.41~11.51	• Confirm
	1400	11.34~11.44	• "
	1700	11.43~11.53	• "
	1800	11.17~11.37	• "
	---	---	• "
	---	---	• "
Confirm injection quantity at points A to C.			
Maximum Speed control Adjustment	1850	10.63~10.83	• Adjust using screw ③.
	1930~2000	8.2	• Confirm • After adjustment, confirm that the control lever angle is 38°~44°
Confirming Excess Fuel Limit for Engine Starting	400	Approx.9.3	• Set the control lever at point J.
	0	11.4~11.6	• Confirm
	0	Above 15	• Move the control lever to the "full-speed" position and then confirm the control rack position.
Confirm the Black Smoke Limit	Fix the control lever at point H. Then, operate the pump at 250 rpm. Confirm that the control rack does not move beyond 11.46 mm. When the control lever is moved to the "full-speed" position again increase the pump speed and confirm that the control rack starts to move from a pump speed of (500) rpm.		
Rack Limiter Adjustment	---	---	• Fix the control rack using screw Part No. 157954-3700
	Measure the depth of the control rack cap. Then, adjust screw ⑥ so that it equals the depth of the rack cap and install the rack cap. Confirm injection quantity at point I.		

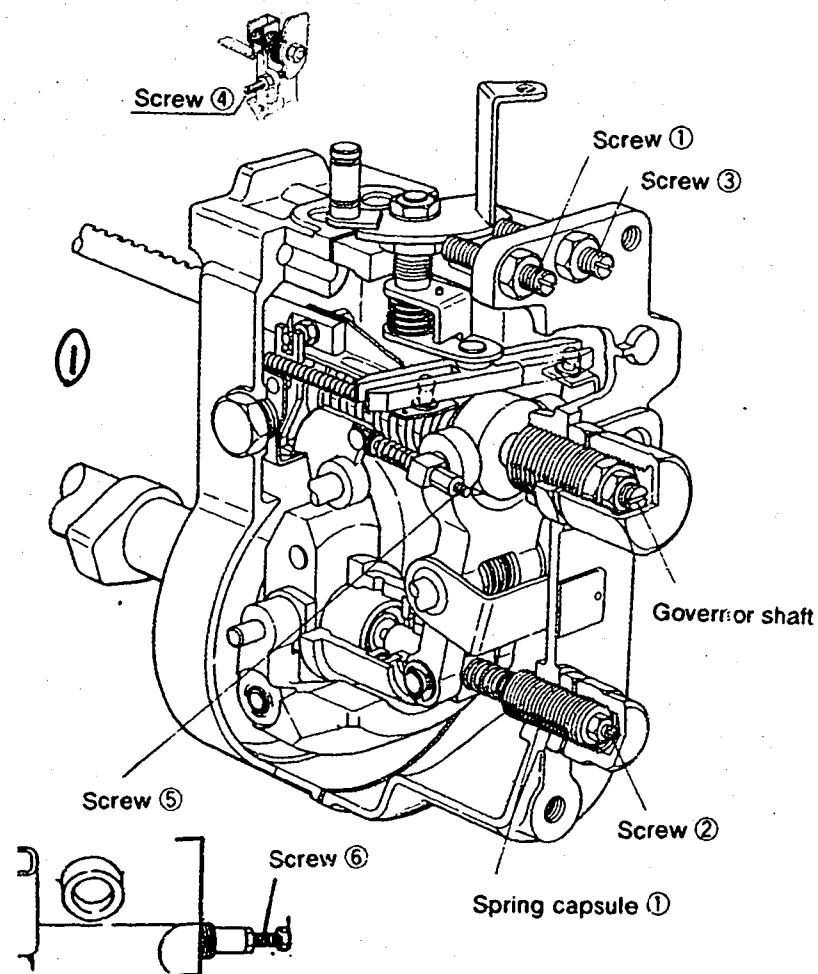

■ Timing Setting

At No. 1 plunger's beginning of injection position.
B.D.T.C. : 12°

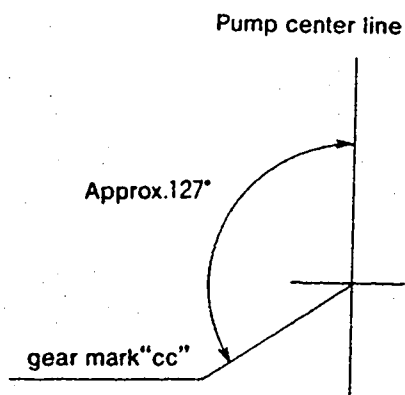

INJ. PUMP CALIBRATION DATA

ENGINE MODEL SL

BOSCH No.9 400 610 018
 DKKC No. 101491-9093
 Date: 20.Nov.1986 [4]
 Company: MAZDA
 No. SL10 13 800C

3. GOVERNOR ADJUSTMENT

101491-9093 2/4

Injection pump : PES4A Governor : EP/RLD
 101049-9131 105921-0721
 Timing device : EP/SCDM
 105670-0080

1. Test Conditions :

Pump rotation : clockwise viewed from drive side

Nozzle & Nozzle Holder Ass'y : 105780-0000 (BOSCH Type No.DN12SD12) Nozzle Holder : 105780-2080 (BOSCH Type No.EF8511/9A)

Nozzle opening pressure : 175 Kg/cm² Transfer pump pressure : 1.6 Kg/cm²

injection pipe : Inner Dia. 2 mm X Outer Dia. 6 mm - Length 600 mm

Test Oil : ISO4113 or SAE Standard Test Oil (SAE J967d) Oil Temp. : 40^{±5} °C

Overflow valve opening pressure : Kg/cm²

2. Injection Timing :

Pre-stroke : No. 1 Plunger 3.4 ±0.05mm
 Note : Adjust with control rod position of mm

Injection order : 1 ~ 3 ~ 4 ~ 2 (interval : 90° ±30')

Plungers are numbered from the Drive side.

Tappet clearance : Bolt adjustment type : More than 0.3mm for all cylinders.
 Shim adjustment type : Manually rotate the camshaft 2~3 times and confirm that it rotates smoothly.

4. Injection Quantity :

Adjusting Point	Rod Position (mm)	Pump Speed (r.p.m)	Injection Q'ty (cc/1000 strokes)	Max. var bet. cyl (%)	Fixed	Remarks
	11.21±0.02	1,000	56.3 ~ 57.3	±2.5	Rack	Basic
H	Approx. 9.3	325	7.0 ~ 11.0	±14	Rack	
A	(11.21)	1,000	56.3 ~ 57.3	-	Lever	Basic
B	(11.48)	1,700	66.9 ~ 70.9	-	Lever	
C	(11.32)	625	40.0 ~ 44.0	-	Lever	
I	Above 15	100	96.0 ~ 116.0	-	Lever	

5. Timing Advance Specification :

Pump Speed (r.p.m)	1,325~1,370	1,700				
Advance Angle (deg.)	Start	Finish	3.2~3.8			

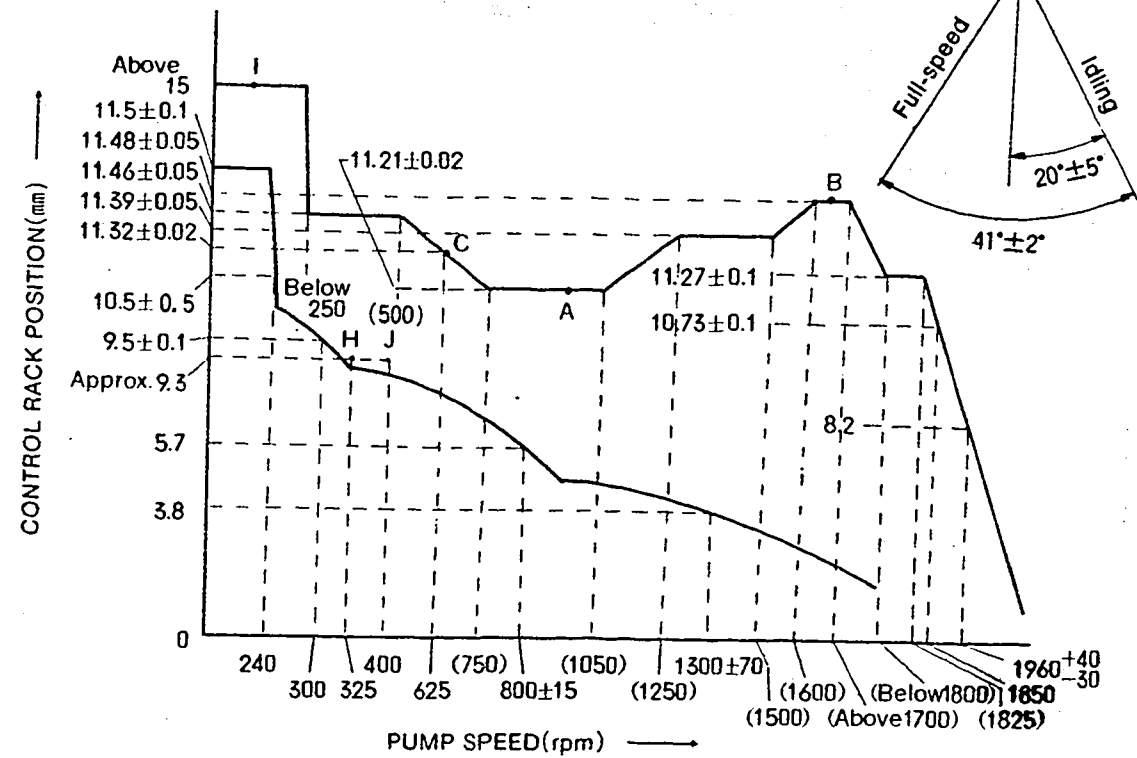

Idling Adjustment

Item	Pump Speed (rpm)	Rack Position (mm)	Remarks
Idling Lever Position: Temporary Setting	80~100	11.4~11.6	• Adjust using screw ①.
Idling Position Setting	300	9.4~9.6	• Adjust using spring capsule ①.
	240	10.0~11.0	• Adjust using screw ②.
Governor Spring Contact Adjustment	785~815	5.7	• Adjust the governor shaft position.
	1230~1370	3.8	• Confirm
Setting the Idling Lever Position	325	Approx.9.3	• Adjust using screw ①.
	—	—	• Confirm the control lever angle (15°~25°)



DIESEL KIKI CO., LTD. 3-6-7 SHIBUYA, SHIBUYA-KU, TOKYO 150, JAPAN
 Service Department Tel. (03) 400-1557 Fax: (03) 499-4115

■ Full Load Adjustment (Torque Cam No. A19)

Item	Pump Speed (rpm)	Rack Position (mm)	Remarks
Full Speed Lever Position: Temporary Setting	Approx.1800	Approx.11.27	• Adjust using screw ③. (Do not enter governor control range)
Full Load Position Adjustment	1000	11.19~11.23	• Adjust using screw ④.
Torque Cam Position Adjustment	625	11.31~11.34	• Adjust using screw ⑤.
	450	11.41~11.51	• Confirm
	1400	11.34~11.44	• "
	1700	11.43~11.53	• "
	1800	11.17~11.37	• "
	---	---	• "
	---	---	• "
Confirm injection quantity at points A to C.			
Maximum Speed control Adjustment	1850	10.63~10.83	• Adjust using screw ③.
	1930~2000	8.2	• Confirm
	---	---	• After adjustment, confirm that the control lever angle is 38°~44°
Confirming Excess Fuel Limit for Engine Starting	400	Approx.9.3	• Set the control lever at point J.
	0	11.4~11.6	• Confirm
	0	Above 15	• Move the control lever to the "full-speed" position and then confirm the control rack position.
Confirm the Black Smoke Limit	Fix the control lever at point H. Then, operate the pump at 250 rpm. Confirm that the control rack does not move beyond 11.46 mm. When the control lever is moved to the "full-speed" position again increase the pump speed and confirm that the control rack starts to move from a pump speed of (500) rpm.		
Rack Limiter Adjustment	---	---	• Fix the control rack using screw Part No. 157954-3700
	Measure the depth of the control rack cap. Then, adjust screw ⑥ so that it equals the depth of the rack cap and install the rack cap. Confirm injection quantity at point I.		

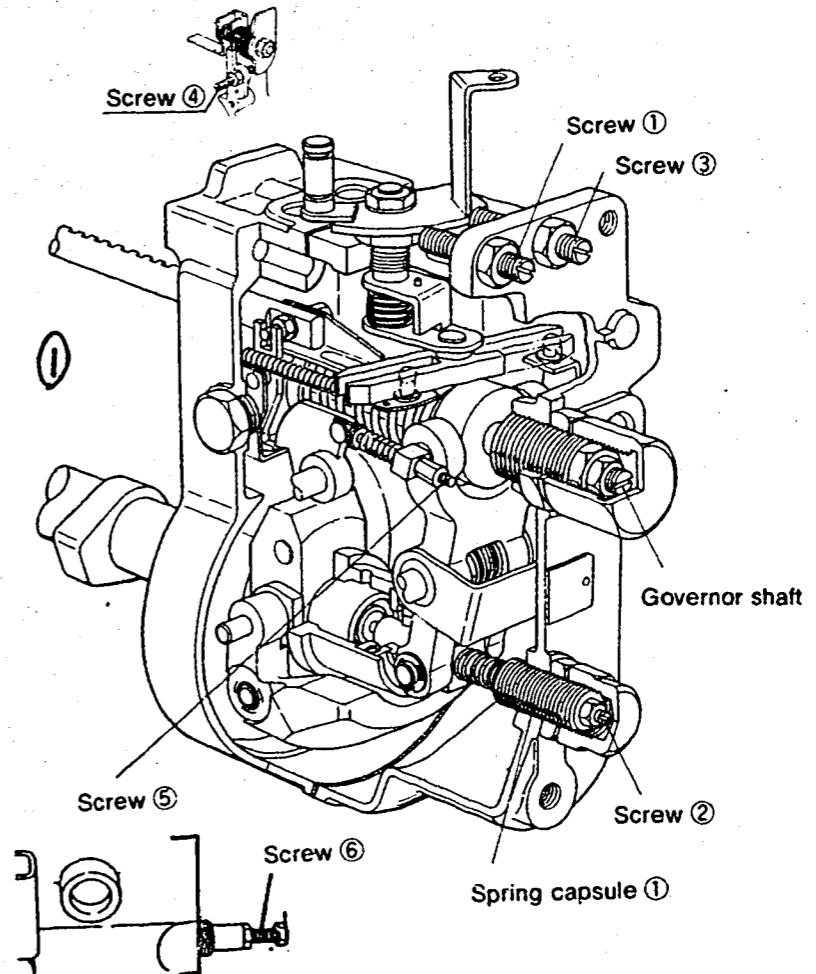

■ Timing Setting

At No. 1 plunger's beginning of injection position.

B.D.T.C. : 12°

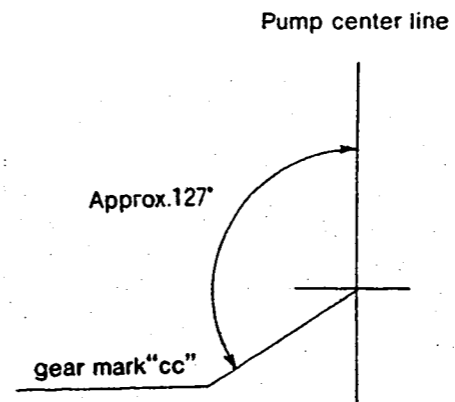

INJ. PUMP CALIBRATION DATA

ENGINE MODEL SL

BOSCH No. 9 400 610 052
 DKKC No. 101491-9094
 Date: 20.Nov.1986 4
 Company: MAZDA
 No. SL10 13 800D

Injection pump : PES4A Governor : EP/RLD Timing device : EP/SCDM
 101049-9190 105921-1230 105670-0080

1. Test Conditions :

Pump rotation : clockwise viewed from drive side

Nozzle & Nozzle Holder Ass'y : 105780-0000 (BOSCH Type No.DN12SD12) Nozzle Holder : 105780-2080 (BOSCH Type No.EF8511/9A)

Nozzle opening pressure : 175 Kg/cm² Transfer pump pressure : 1.6 Kg/cm²

Injection pipe : Inner Dia. 2 mm X Outer Dia. 6 mm - Length 600 mm

Test Oil : ISO4113 or SAE Standard Test Oil (SAE J967d) Oil Temp. : 40^{±5} °C

Overflow valve opening pressure : Kg/cm²

2. Injection Timing :

Pre-stroke : No. 1 Plunger 3.4 ±0.05mm
 Note : Adjust with control rod position of mm

Injection order : 1 ~ 3 ~ 4 ~ 2 (interval : 90° ±30°)

Plungers are numbered from the Drive side.

Tappet clearance : Bolt adjustment type : More than 0.3mm for all cylinders.
 Shim adjustment type : Manually rotate the camshaft 2~3 times and confirm that it rotates smoothly.

4. Injection Quantity :

Adjust- ing Point	Rod Position (mm)	Pump Speed (r.p.m)	Injection Q'ty (cc/1000 strokes)	Max. var bet. cyl (%)	Fixed	Remarks
	11.21±0.02	1,000	56.3 ~ 57.3	±2.5	Rack	Basic
H	Approx. 9.3	325	7.0 ~ 11.0	±14	Rack	
A	(11.21)	1,000	56.3 ~ 57.3	-	Lever	Basic
B	(11.48)	1,700	66.9 ~ 70.9	-	Lever	
C	(11.32)	625	40.0 ~ 44.0	-	Lever	
I	Above 15	100	96.0 ~ 116.0	-	Lever	

5. Timing Advance Specification :

Pump Speed (r.p.m)	1,325~ 1,370	1,700				
Advance Angle (deg.)	Start	Finish 3.2~3.8				

3. GOVERNOR ADJUSTMENT

101491-9094 2/4

CONTROL LEVER ANGLE

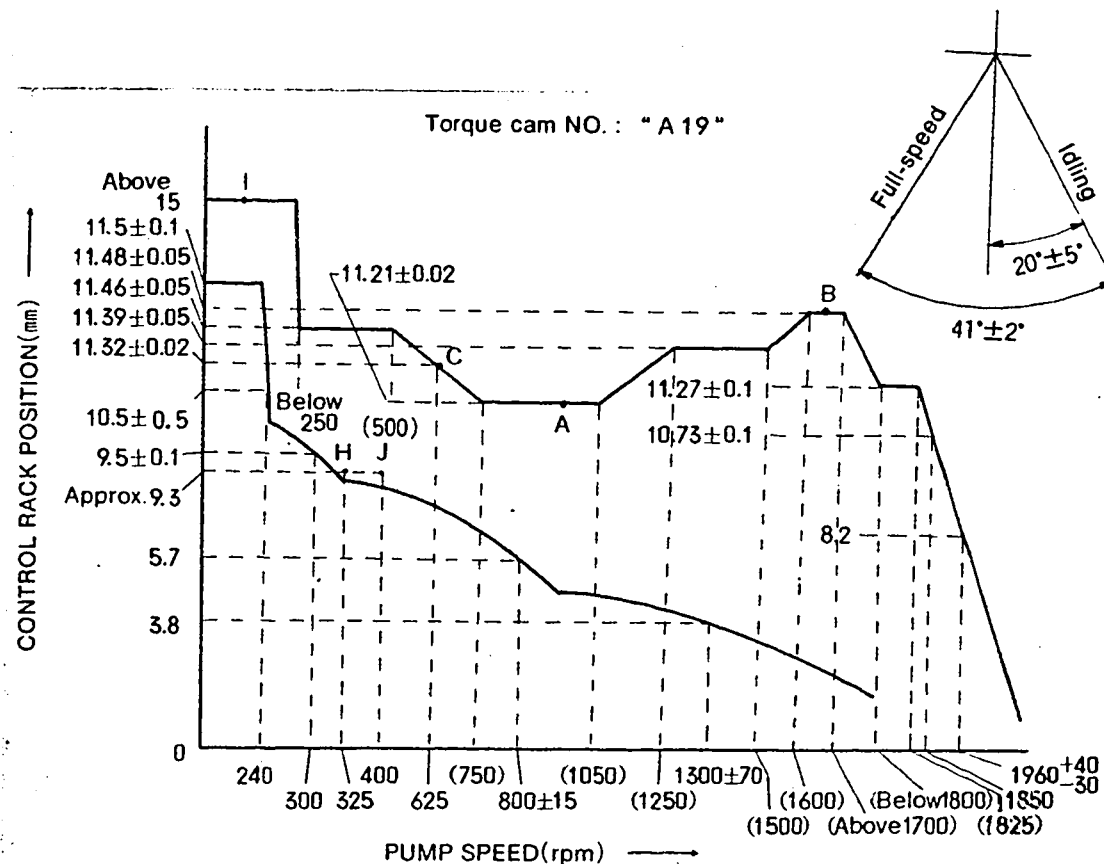

■ Idling Adjustment

Item	Pump Speed (rpm)	Rack Position (mm)	Remarks
Idling Lever Position: Temporary Setting	80~100	11.4~11.6	• Adjust using screw ①.
Idling Position Setting	300	9.4~9.6	• Adjust using spring capsule ①. • Adjust using screw ②.
	240	10.0~11.0	
Governor Spring Contact Adjustment	785~815	5.7	• Adjust the governor shaft position.
	1230~1370	3.8	• Confirm
Setting the Idling Lever Position	325	Approx. 9.3	• Adjust using screw ①. • Confirm the control lever angle (15°~25°)

■ Full Load Adjustment (Torque Cam No. A19)

Item	Pump Speed (rpm)	Rack Position (mm)	Remarks
Full Speed Lever Position: Temporary Setting	Approx.1800	Approx.11.27	• Adjust using screw ③. (Do not enter governor control range)
Full Load Position Adjustment	1000	11.19~11.23	• Adjust using screw ④.
Torque Cam Position Adjustment	625	11.31~11.34	• Adjust using screw ⑤.
	450	11.41~11.51	• Confirm
	1400	11.34~11.44	• "
	1700	11.43~11.53	• "
	1800	11.17~11.37	• "
	---	---	• "
	---	---	• "
Confirm injection quantity at points A to C.			
Maximum Speed control Adjustment	1850	10.63~10.83	• Adjust using screw ③.
	1930~2000	8.2	• Confirm
	---	---	• After adjustment, confirm that the control lever angle is 38°~44°
Confirming Excess Fuel Limit for Engine Starting	400	Approx.9.3	• Set the control lever at point J .
	0	11.4~11.6	• Confirm
	0	Above 15	• Move the control lever to the "full-speed" position and then confirm the control rack position.
Confirm the Black Smoke Limit	Fix the control lever at point H. Then, operate the pump at 250 rpm. Confirm that the control rack does not move beyond 11.46 mm. When the control lever is moved to the "full-speed" position again increase the pump speed and confirm that the control rack starts to move from a pump speed of (500) rpm.		
Rack Limiter Adjustment	---	---	• Fix the control rack using screw Part No. 157954-3700
	Measure the depth of the control rack cap. Then, adjust screw ⑥ so that it equals the depth of the rack cap and install the rack cap. Confirm injection quantity at point I .		

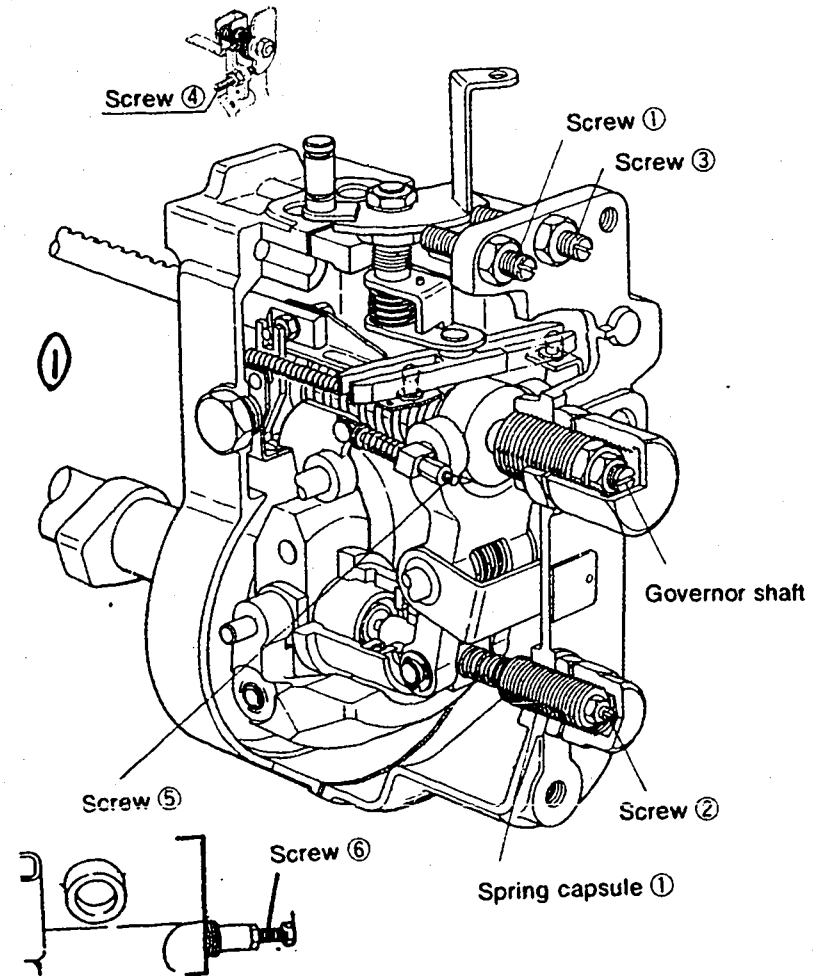

■ Timing Setting

At No. 1 plunger's beginning of injection position.
B.D.T.C. : 12°

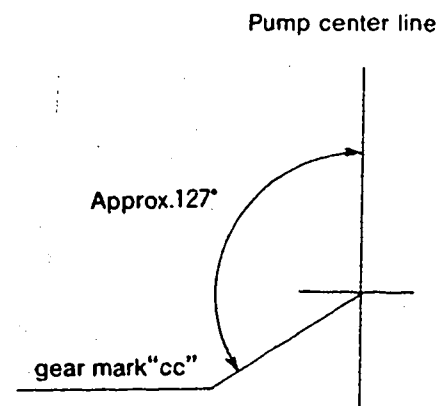

INJ. PUMP CALIBRATION DATA

ENGINE MODEL 6D14

BOSCH No. 9 400 610 023
 DKKC No. 101601-1480
 Date: 20.Nov.1986 [4]
 Company: MITSUBISHI
 No. ME036543

Injection pump : PES6A 101060-9081 Governor : EP/RFD 105490-1270 Timing device : EP/SBZ 105624-5040

1. Test Conditions :

Pump rotation : Counter clockwiseviewed from drive side

Nozzle & Nozzle Holder Ass'y : 105780-0000 (BOSCH Type No.DN12SD12) Nozzle Holder : 105780-2080 (BOSCH Type No.EF8511/9A)
 Nozzle opening pressure : 175 Kg/cm² Transfer pump pressure : 1.6 Kg/cm²

Injection pipe :

Inner Dia. 2 mm X Outer Dia. 6 mm - Length 600 mm

Test Oil : ISO4113 or SAE Standard Test Oil (SAE J967d) Oil Temp. : 40^{±5} °C

Overflow valve opening pressure : Kg/cm²

2. Injection Timing :

Pre-stroke : No. 1 Plunger 3.3 ±0.05mm

Note : Adjust with control rod position of mm

Injection order : 1 ~ 5 ~ 3 ~ 6 ~ 2 ~ 4 (interval : 60° ± 30')

Plungers are numbered from the Governor side.

Tappet clearance : Bolt adjustment type ; More than 0.3mm for all cylinders.
 ; Shim adjustment type ; Manually rotate the camshaft 2~3 times and confirm that it rotates smoothly.

4. Injection Quantity :

Adjusting Point	Rod Position (mm)	Pump Speed (r.p.m)	Injection Q'ty (cc/1000 strokes)	Max. var bet. cyl (%)	Fixed	Remarks
A	11.5	1,000	71.7 ~ 73.7	±2.5	Rack	Basic
H	Approx. 9.0	275	6.4 ~ 8.8	±15	Rack	
A	11.5	1,000	71.7 ~ 73.7	-	Lever	Basic
B	11.5	1,580	71.0 ~ 77.0	±4	Lever	

5. Timing Advance Specification :

Pump Speed (r.p.m)	950~1,050	1,300	1,600			
Advance Angle (deg.)	Start	0.5~1.5	Finish	1.5~2.5		

3. GOVERNOR ADJUSTMENT

101601-1480 2/4

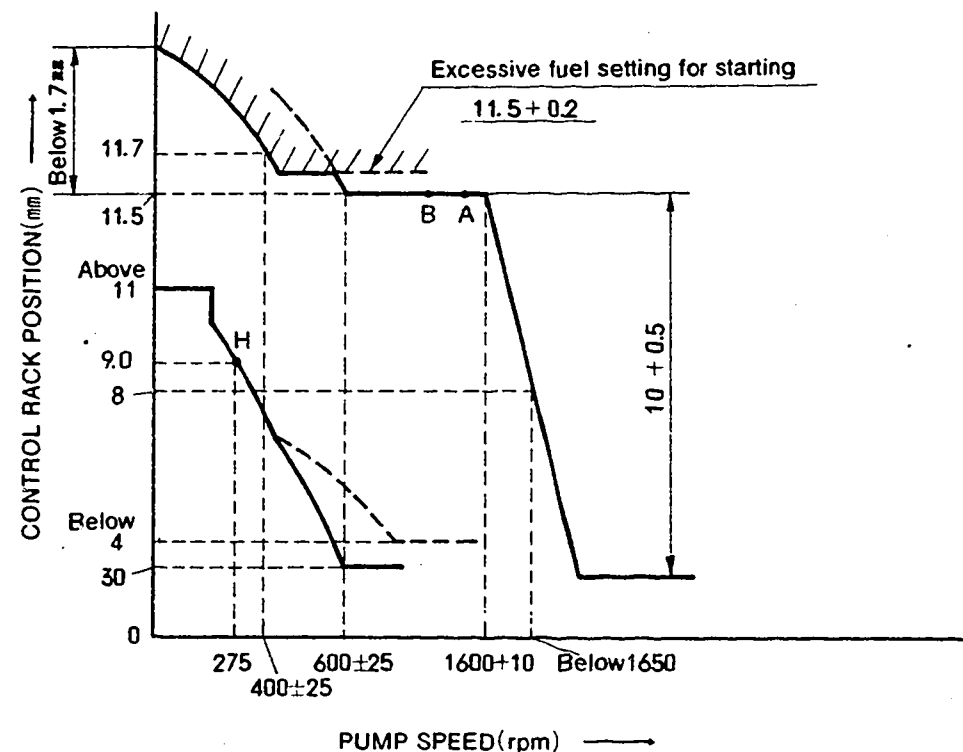

• LOAD CONTROL LEVER ANGLE

• SPEED CONTROL LEVER ANGLE

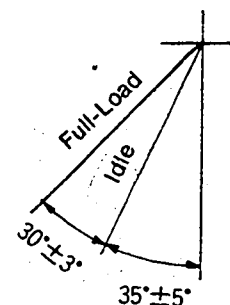

Note :

Before adjustment, remove the damper spring, the cover and the idling spring capsule.

■ Adjustment

Item	Pump Speed (rpm)	Rack Position (mm)	Remarks
Flyweight Lift And Full-Load Position	700~800	11.5	• Speed control lever: temporary setting.
	Above 1650	0.1~0.2	• Adjust using screw ①.
Decrease pump speed to 1500 rpm and adjust the high speed lift value (10+0.5) using screw ②.			
Idling Adjustment	575~625	310	• Adjust using screw ③
	275	9.0	• Adjust using spring capsule ①
	575~625	3.0	• Confirm
	0	Above 11	• Confirm
	—	—	• Confirm the control lever angle is 30°~40°.
Damper Spring Setting	Maintain the pump speed at 275 rpm and set the control rod at the 9.0mm position using the control lever. Then, gradually increase the pump speed until the rod position is 6.5-0.2mm. Tighten the damper spring capsule and fix it in the position where it begins to move the rod from the 6.5-0.1mm position.		
Maximum Speed Starting Point and Speed Droop Check	Fix the load control lever in the full-load position and fix the speed control lever in the full-speed position.		
	1600~1610	11.5	• Adjust using screw ④
	Below 1650 Above 1700	8 —	• Confirm • Confirm that there is no fuel injection.
Smoke Limiter Setting	Fix the load control lever in the full-load position.		
	500 —	11.5+0.2 —	• Adjust using smoke limiter. • Confirm injection quantity at point E.

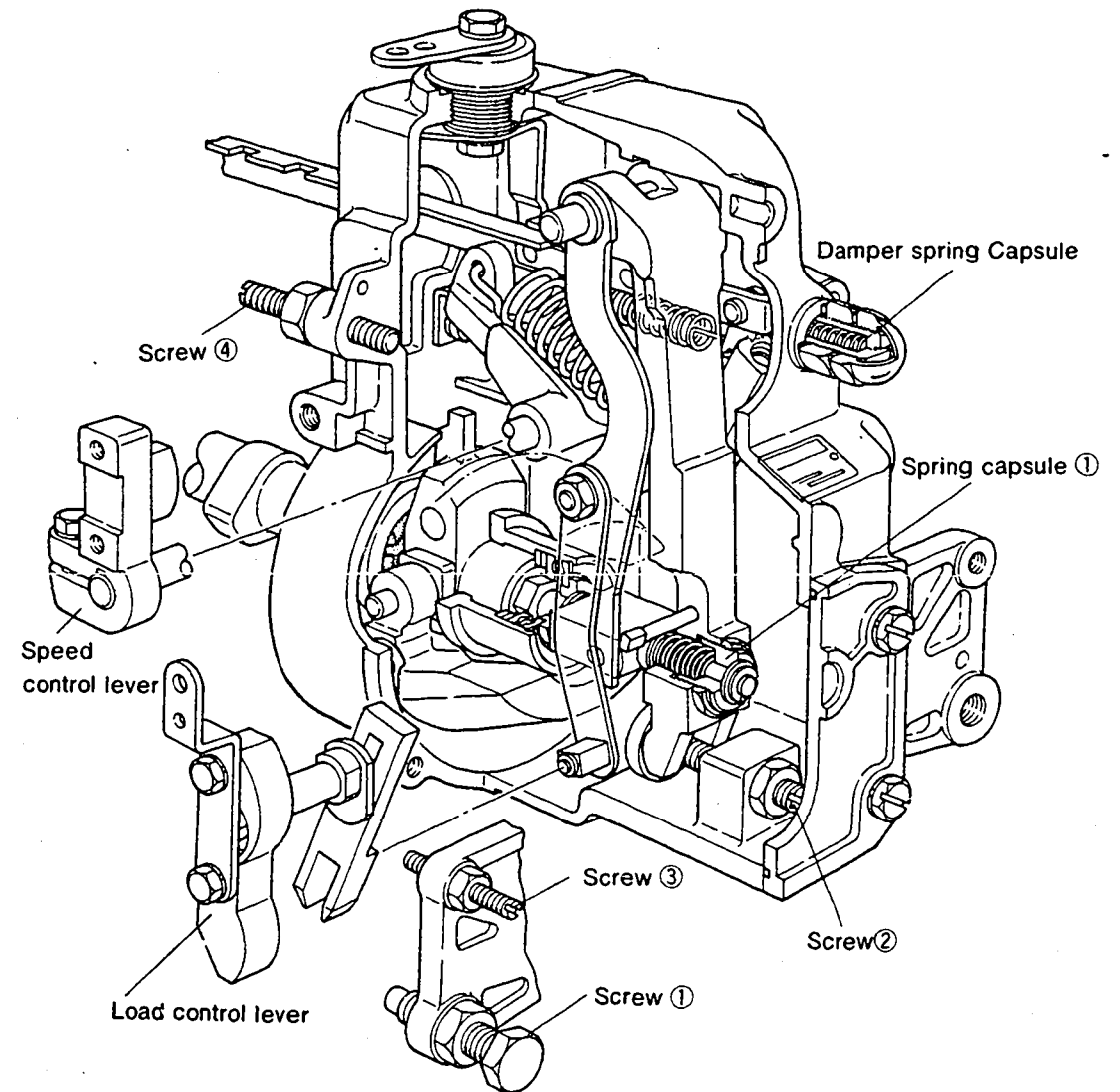

INJ. PUMP CALIBRATION DATA

ENGINE MODEL 6D20

BOSCH No. 9 400 610 048
 DKKC No. 101601-1521
 Date: 20.Nov.1986 3
 Company: MITSUBISHI
 No. 30961-90020

Injection pump : PE6AD 101060-2540 Governor : EP/RSV 105412-1640 Timing device : EP/SA 105614-4010

1. Test Conditions :

Pump rotation : clockwise viewed from drive side

Nozzle & Nozzle Holder Ass'y : 105780-0000 (BOSCH Type No. DN12SD12) Nozzle Holder : 105780-2080 (BOSCH Type No. EF8511/9A)
 Nozzle opening pressure : 175 Kg/cm² Transfer pump pressure : 1.6 Kg/cm²

Injection pipe : Inner Dia. 2 mm X Outer Dia. 6 mm - Length 600 mm

Test Oil : ISO4113 or SAE Standard Test Oil (SAE J967d) Oil Temp. : 40⁺5 °C

Overflow valve opening pressure : 1.6 Kg/cm²

2. Injection Timing :

Pre-stroke : No. 1 Plunger 4.5 ±0.05mm
 Note : Adjust with control rod position of _____ mm

Injection order : 1 ~ 5 ~ 3 ~ 6 ~ 2 ~ 4 (interval : 60° ± 30°)

Plungers are numbered from the Governor side.

Tappet clearance : Bolt adjustment type ; More than 0.3mm for all cylinders.
 Shim adjustment type ; Manually rotate the camshaft 2~3 times and confirm that it rotates smoothly.

4. Injection Quantity :

Adjusting Point	Rod Position (mm)	Pump Speed (r.p.m)	Injection Q'ty (cc/1000 strokes)	Max. var bet. cyl (%)	Fixed	Remarks
A	9.1	1,000	101.0 ~ 105.0	±3	Rack	Basic
H	Approx. 8.0	225	16.9 ~ 22.1	±15	Rack	
B	9.4	700	98.5 ~ 104.5	±14	Lever	Basic
D	Above 13	100	Above 135	—	Lever	

5. Timing Advance Specification :

Pump Speed (r.p.m)	800~920	1,000	1,250			
Advance Angle (deg.)	Start	0.4~1.4	Finish	4~5		

3. GOVERNOR ADJUSTMENT

101601-1521 2/4

CONTROL LEVER ANGLE

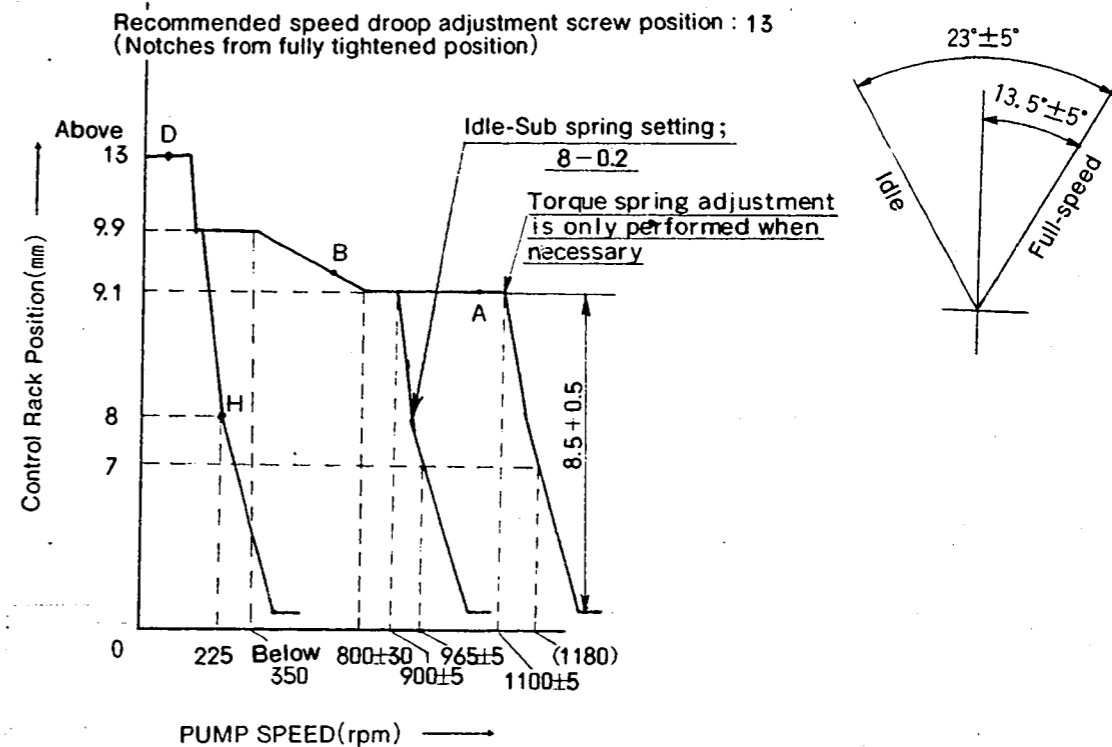

Note

- Before adjustment, remove the idling sub spring and the torque control spring.
- Move the control lever fully in the stop direction, and set the minimum-speed stopper bolt so that the control rack position is 0.5~1.0 mm.

Adjustment

Item	Pump Speed (rpm)	Rack Position (mm)	Remarks
Full-load Adjustment (Temporary)	1095~1105	9.1	• Adjust using screw ①
	1000	9.1	• Adjust using screw ②
Torque Control Spring Adjustment	Approx. 300	9.9	• Adjust using spring capsule ①
	Below 350	9.9	• Confirm
	770~830	9.1	• Confirm
			• Confirm the torque control stroke is mm.

101601-1521 3/4

101601-1521 4/4

Item	Pump Speed (rpm)	Rack Position (mm)	Remarks
Idling Adjustment	0 225 —	Above 13 8 —	<ul style="list-style-type: none"> • Fix the control lever • Adjust using spring capsule ② • Confirm
Maximum-speed Adjustment	895~905	9.1	• Adjust using screw ①
	960~970	7.0	• Confirm speed droop
	1095~1105 (1180)	9.1 7.0	<ul style="list-style-type: none"> • Confirm • Confirm
Full-load Adjustment (Install the cover on governor cover)	1000	9.1	• Adjust using screw ②
Control Lever Angle Measurement	<ul style="list-style-type: none"> • Measure the control lever angle at the "idling" and "full" positions. • When the control lever is depressed toward the "full" position, replace the shifter's shim with a thicker one. • When the control lever is depressed toward the "idling" position, replace the shifter's shim with a thinner one. 		
Rack Limiter Adjustment	—	—	• Adjust using screw

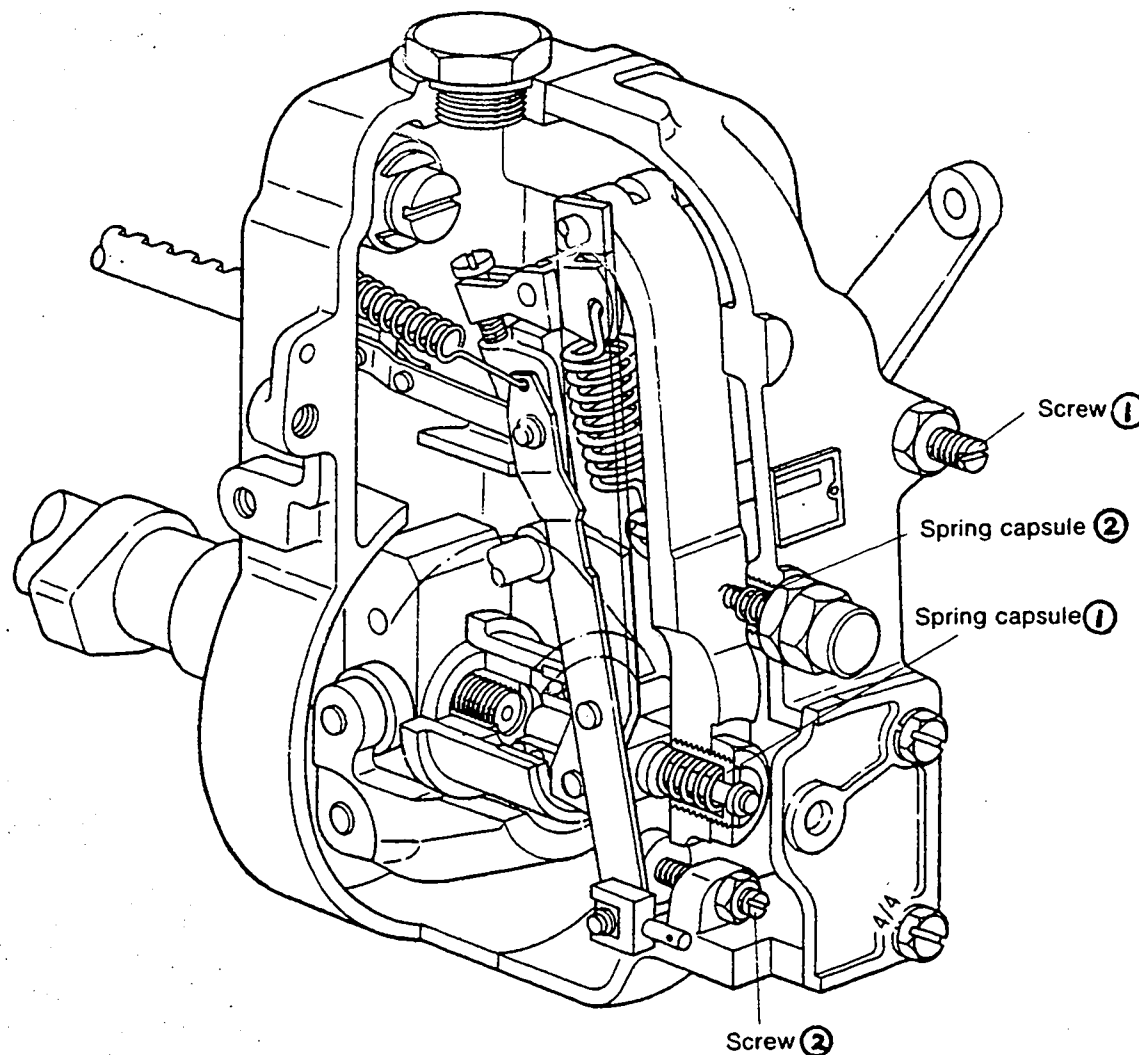

INJ. PUMP CALIBRATION DATA

ENGINE MODEL 6BD1T

BOSCH No. 9 400 610 019
 DKKC No. 101601-8651
 Date: 20.Nov.1986 5
 Company: ISUZU
 No. 1-15601-679-1

Injection pump : PE6A 101060-2120 Governor : EP/RLD 105931-2051 Timing device : EP/SA 105612-3250

1. Test Conditions :

Pump rotation : clockwise viewed from drive side

Nozzle & Nozzle Holder Ass'y : 105780-0000 (BOSCH Type No.DN12SD12) Nozzle Holder : 105780-2080 (BOSCH Type No.EF8511/9A)

Nozzle opening pressure : 175 Kg/cm² Transfer pump pressure : 1.6 Kg/cm²

Injection pipe : Inner Dia. 1.8 mm X Outer Dia. 6 mm - Length 600 mm

Test Oil : ISO4113 or SAE Standard Test Oil (SAE J967d) Oil Temp. : 40^{±5} °C

Overflow valve opening pressure : 1.6 Kg/cm²

2. Injection Timing :

Pre-stroke : No. 1 Plunger 3.4 ±0.05mm

Note : Adjust with control rod position of _____ mm

Injection order : 1 ~ 5 ~ 3 ~ 6 ~ 2 ~ 4 (interval : 60° ±30')

Plungers are numbered from the Drive side.

Tappet clearance : Bolt adjustment type : More than 0.3mm for all cylinders.
 Shim adjustment type : Manually rotate the camshaft 2~3 times and confirm that it rotates smoothly.

4. Injection Quantity :

Adjusting Point	Rod Position (mm)	Pump Speed (r.p.m)	Injection Q'ty (cc/1000 strokes)	Max. var bet. cyl (%)	Fixed	Remarks
	10.6	1,000	70.4 ~ 73.6	±2.5	Rack	Basic
H	Approx. 9.5	290	8.1 ~ 10.7	±14	Rack	
A	R _i (10.6)	1,000	71.0 ~ 73.0	—	Lever	Basic
B	R _i -0.1	1,500	(74.8 ~ 78.1)	—	Lever	
C	R _i -0.25	500	(44.9 ~ 48.1)	—	Lever	

5. Timing Advance Specification :

Pump Speed (r.p.m)	Below 1,050	1,000	(1,300)	1,500		
Advance Angle (deg.)	Start	Below 0.5	0.5~1.5	Finish 0.5~1.5		

3. GOVERNOR ADJUSTMENT

101601-8651 2/4

CONTROL LEVER ANGLE

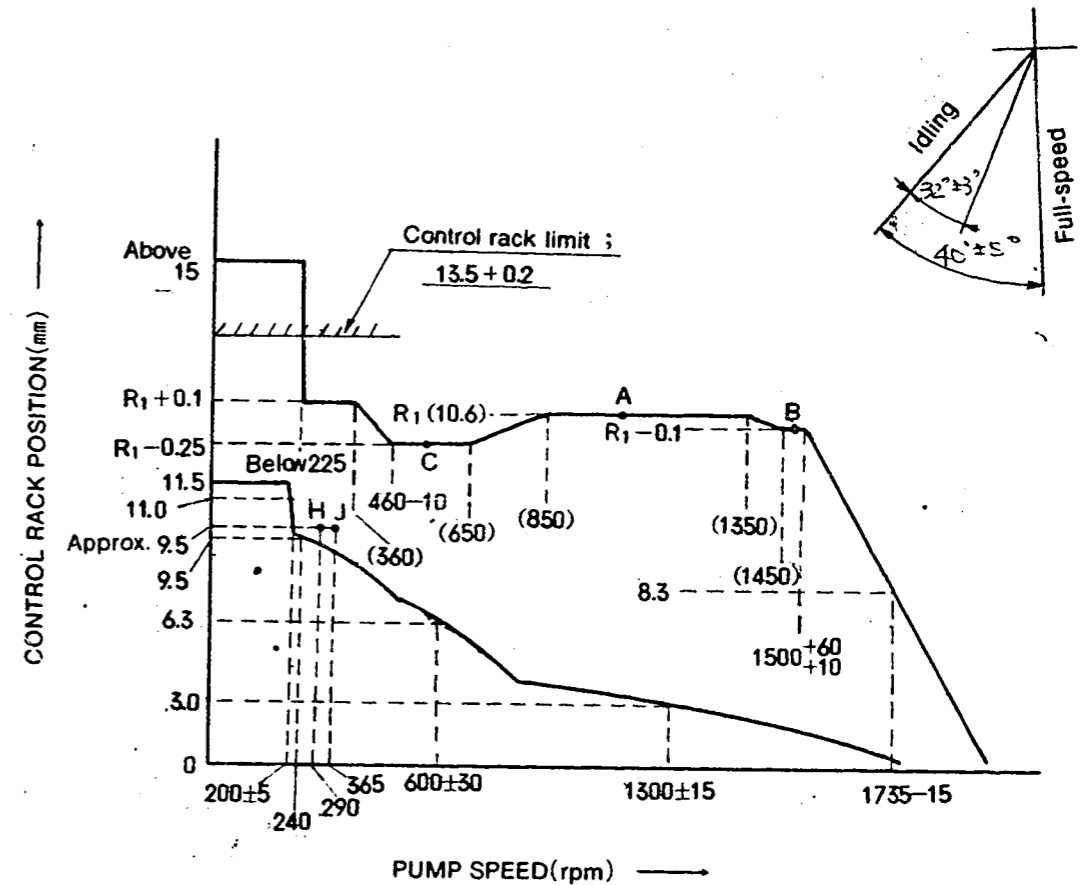

■ Idling Adjustment

Item	Pump Speed (rpm)	Rack Position (mm)	Remarks
Idling Lever Position: Temporary Setting	80~100	11.5	• Adjust using screw ①.
Idling Position Setting	240	9.5	• Adjust using spring capsule ①.
	195~205	11.0	• Adjust using screw ②.
Governor Spring Contact Adjustment	570~630	6.3	• Adjust the governor shaft position.
	1285~1315	3.0	• Confirm
Setting the Idling Lever Position	290	Approx. 9.5	• Adjust using screw ①.
	—	—	• Confirm the control lever angle (35°~45°)

■ Full Load Adjustment (Torque Cam No. B51)

Item	Pump Speed (rpm)	Rack Position (mm)	Remarks
Full Speed Lever Position: Temporary Setting	1500	(10.6) - 0.1	• Adjust using screw ③. (Do not enter governor control range)
Full Load Position Adjustment	1000	(10.6)	• Adjust using screw ④.
Torque Cam Position Adjustment	450~460	(10.6) - 0.25	• Adjust using screw ⑤.
	(360)	(10.6) + 0.1	• Confirm
	450~460	(10.6) - 0.25	• "
	(650)	(10.6) - 0.25	• "
	(850)	(10.6)	• "
	(1350)	(10.6)	• "
	(1450)	(10.6) - 0.1	• "
	—	—	• "
Confirm injection quantity at points A to C.			
Maximum Speed control Adjustment	1510~1560	(10.6) - 0.1	• Adjust using screw ③.
	1720~1750	8.3	• Confirm • After adjustment, confirm that the control lever angle is 29°~35°
Confirming Excess Fuel Limit for Engine Starting	365	Approx. 9.5	• Set the control lever at point J.
	0	11.5	• Confirm
	0	Above 15	• Move the control lever to the "full-speed" position and then confirm the control rack position.
Confirm the Black Smoke Limit	Fix the control lever at point H. Then, operate the pump at 225 rpm. Confirm that the control rack does not move beyond 10.7 mm. When the control lever is moved to the "full-speed" position again increase the pump speed and confirm that the control rack starts to move from a pump speed of (360) rpm.		
Rack Limiter Adjustment	0	13.5~13.7	• Fix the control rack using screw Part No. 157954-3700

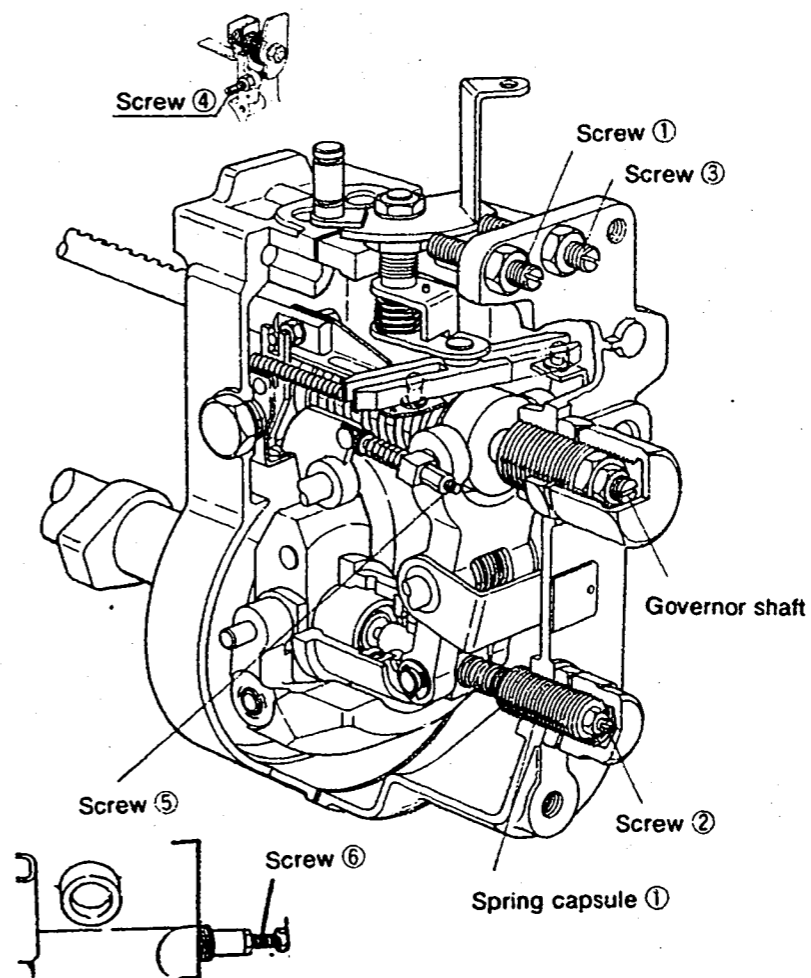

INJ. PUMP CALIBRATION DATA

ENGINE MODEL 6BD1T

BOSCH No. 9 400 610 020
 DKKC No. 101601-8671
 Date: 20.Nov.1986 [5]
 Company: ISUZU
 No. 1-15601-867-1

3. GOVERNOR ADJUSTMENT

101601-8671 2/4

Injection pump : PE6A Governor : EP/RLD Timing device : EP/SA
 101060-2120 105931-2071 105612-3250

1. Test Conditions :

Pump rotation : clockwise viewed from drive side

Nozzle & Nozzle Holder Ass'y : 105780-0000 (BOSCH Type No.DN12SD12) Nozzle Holder : 105780-2080 (BOSCH Type No.EF8511/9A)

Nozzle opening pressure : 175 Kg/cm² Transfer pump pressure : 1.6 Kg/cm²

Injection pipe : Inner Dia. 1.8 mm X Outer Dia. 6 mm - Length 600 mm

Test Oil : ISO4113 or SAE Standard Test Oil (SAE J967d) Oil Temp. : 40⁺5 °C

Overflow valve opening pressure : 1.6 Kg/cm²

2. Injection Timing :

Pre-stroke : No. 1 Plunger 3.4 ±0.05mm
 Note : Adjust with control rod position of mm

Injection order : 1 ~ 5 ~ 3 ~ 6 ~ 2 ~ 4 (interval : 60° ±30')

Plungers are numbered from the Drive side.

Tappet clearance : Bolt adjustment type : More than 0.3mm for all cylinders.
 : Shim adjustment type : Manually rotate the camshaft 2~3 times and confirm that it rotates smoothly.

4. Injection Quantity :

Adjusting Point	Rod Position (mm)	Pump Speed (r.p.m)	Injection Q'ty (cc/1000 strokes)	Max. var bet. cyl (%)	Fixed	Remarks
	10.6	1,000	71.4 ~ 73.6	±2.5	Rack	Basic
H	Approx. 9.5	290	8.1 ~ 10.7	±14	Rack	
A	R ₁ (10.6)	1,000	71.0 ~ 73.0	-	Lever	Basic
B	R ₁ -0.1	1,500	(74.9 ~ 78.1)	-	Lever	
C	R ₁ -0.25	500	(44.9 ~ 48.1)	-	Lever	

5. Timing Advance Specification :

Pump Speed (r.p.m)	Below 1,050	1,000	1,300	1,500
Advance Angle (deg.)	Start	Below 0.5	0.5~1.5	Finish 0.5~1.5

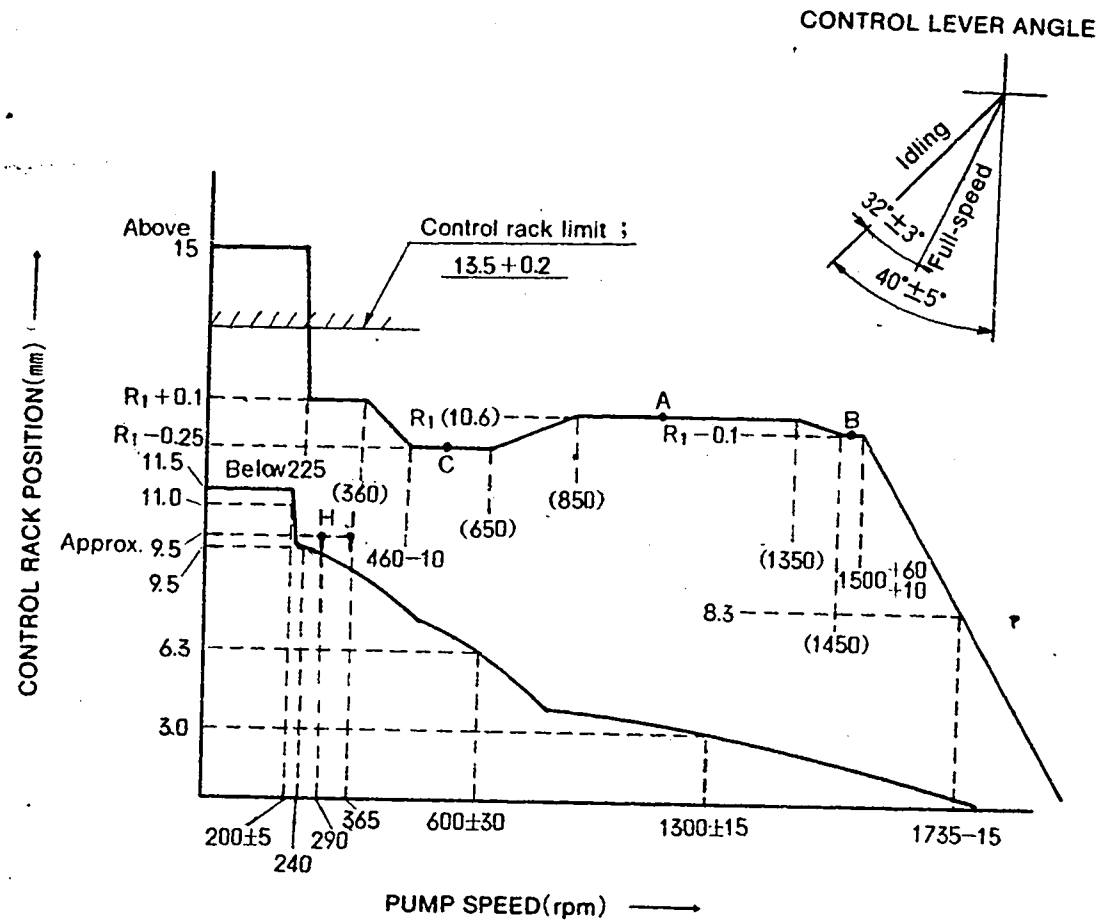

Idling Adjustment

Item	Pump Speed (rpm)	Rack Position (mm)	Remarks
Idling Lever Position: Temporary Setting	80~100	11.5	• Adjust using screw ①.
Idling Position Setting	240	9.5	• Adjust using spring capsule ①.
	195~205	11.0	• Adjust using screw ②.
	570~630	6.3	• Adjust shim ① inside the spring capsule.
Governor Spring Contact Adjustment	570~630	6.3	• Adjust the governor shaft position.
	1285~1315	3.0	• Confirm
Setting the Idling Lever Position	290	Approx.9.5	• Adjust using screw ①.
	—	—	• Confirm the control lever angle (35°~45°)



DIESEL KIKI CO., LTD. 3-6-7 SHIBUYA, SHIBUYA-KU, TOKYO 150, JAPAN
 Service Department Tel. (03) 400-1551 Fax: (03) 499-4115

■ Full Load Adjustment (Torque Cam No. B51)

Item	Pump Speed (rpm)	Rack Position (mm)	Remarks
Full Speed Lever Position: Temporary Setting	Approx.1500	(10.6)-0.1	• Adjust using screw ③. (Do not enter governor control range)
Full Load Position Adjustment	1000	(10.6)	• Adjust using screw ④.
Torque Cam Position Adjustment	450~460	(10.6)-0.25	• Adjust using screw ⑤.
	(360)	(10.6)+0.1	• Confirm
	450~460	(10.6)-0.25	• "
	(650)	(10.6)-0.25	• "
	(850)	(10.6)	• "
	(1350)	(10.6)	• "
	(1450)	(10.6)-0.1	• "
	—	—	• "
Confirm injection quantity at points A to C.			
Maximum Speed control Adjustment	1510~1560	(10.6)-0.1	• Adjust using screw ③.
	1720~1750	8.3	• Confirm
	—	—	• After adjustment, confirm that the control lever angle is 29°~35°
Confirming Excess Fuel Limit for Engine Starting	365	approx.9.5	• Set the control lever at point J .
	0	11.5	• Confirm
	0	Above 15	• Move the control lever to the "full-speed" position and then confirm the control rack position.
Confirm the Black Smoke Limit	Fix the control lever at point H. Then, operate the pump at 225 rpm. Confirm that the control rack does not move beyond 10.7 mm. When the control lever is moved to the "full-speed" position again increase the pump speed and confirm that the control rack starts to move from a pump speed of (360) rpm.		
Rack Limiter Adjustment	0	13.5~13.7	• Fix the control rack using screw Part No. 157954-3700

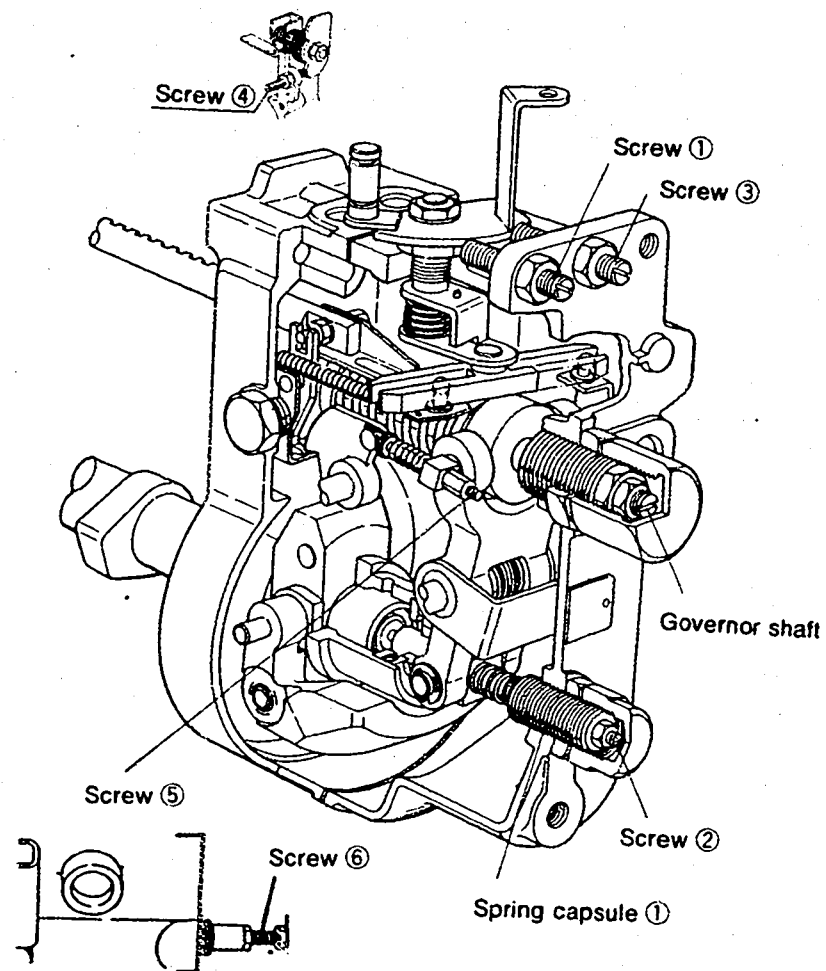

■ Tamper Proof Adjustment

1. After torque cam adjustment, temporarily set the load control lever at a pump speed of 1000 rpm and adjust using the load control lever to obtain a control rack position of $R_1 + 0.4$ mm.
2. Then, adjust using the screw to obtain a control rack position of R_1 .
3. After screw adjustment, adjust the load control lever to obtain a control rack position of R_1 .

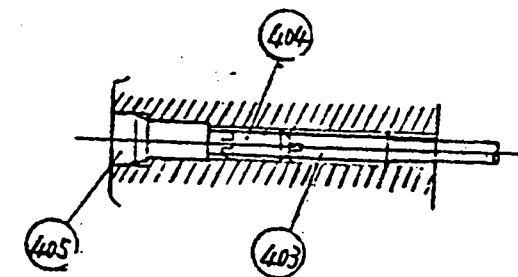
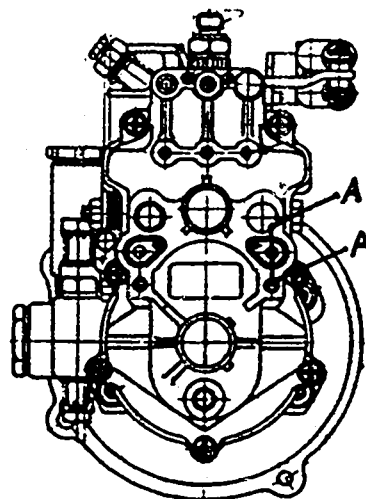

SECTION A-A

INJ. PUMP CALIBRATION DATA

ENGINE MODEL 6D22

BOSCH No. 9 400 610 039
 DKKC No. 101603-1341
 Date: 20.Nov.1986
 Company: MITSUBISHI
 No. ME056176

Injection pump : PE6AD 101060-2421 Governor : EP/RFD 105490-4230 Timing device : EP/SA 105614-4100

1. Test Conditions :

Pump rotation : clockwise viewed from drive side

Nozzle & Nozzle Holder Ass'y : 105780-0000 (BOSCH Type No.DN12SD12) Nozzle Holder : 105780-2080 (BOSCH Type No.EF8511/9A)

Nozzle opening pressure : 175 Kg/cm² Transfer pump pressure : 1.6 Kg/cm²

Injection pipe : Inner Dia. 2 mm X Outer Dia. 6 mm - Length 600 mm

Test Oil : ISO4113 or SAE Standard Test Oil (SAE J967d) Oil Temp. : 40^{±5} °C

Overflow valve opening pressure : 2.6 Kg/cm²

2. Injection Timing :

Pre-stroke : No. 1 Plunger 4.5 ±0.05mm
 Note : Adjust with control rod position of mm

Injection order : 1 ~ 5 ~ 3 ~ 6 ~ 2 ~ 4 (interval : 60 °±30')

Plungers are numbered from the Governor side.

Tappet clearance : Bolt adjustment type ; More than 0.3mm for all cylinders.
 Shim adjustment type ; Manually rotate the camshaft 2~3 times and confirm that it rotates smoothly.

4. Injection Quantity :

Adjusting Point	Rod Position (mm)	Pump Speed (r.p.m)	Injection Q'ty (cc/1000 strokes)	Max. var bet. cyl (cc)	Fixed	Remarks
	9.6	700	108.6 ~ 115.4	—	Rack	Basic Each cylinder
C	Approx. 8.0	200	15.7 ~ 21.3	—	Rack	
A	R _i (9.6)	700	111.0 ~ 113.0	—	Lever	Basic
B	R _i (9.6)	1,100	q _A -1 ≤ q _B ≤ q _A +4	9	Lever	
D	R _i +0.2	500	—	—	Lever	
E	—	100	120.0 ~ 160.0	—	Lever	After setting excessive fuel for starting

5. Timing Advance Specification :

Pump Speed (r.p.m)	0	800	900	1,150	—	
Advance Angle (deg.)	Start	Below (0.5)	0.4~1.4	(2.5~3.5)	Finish 4~5	

3. GOVERNOR ADJUSTMENT

101603-1341 2/4

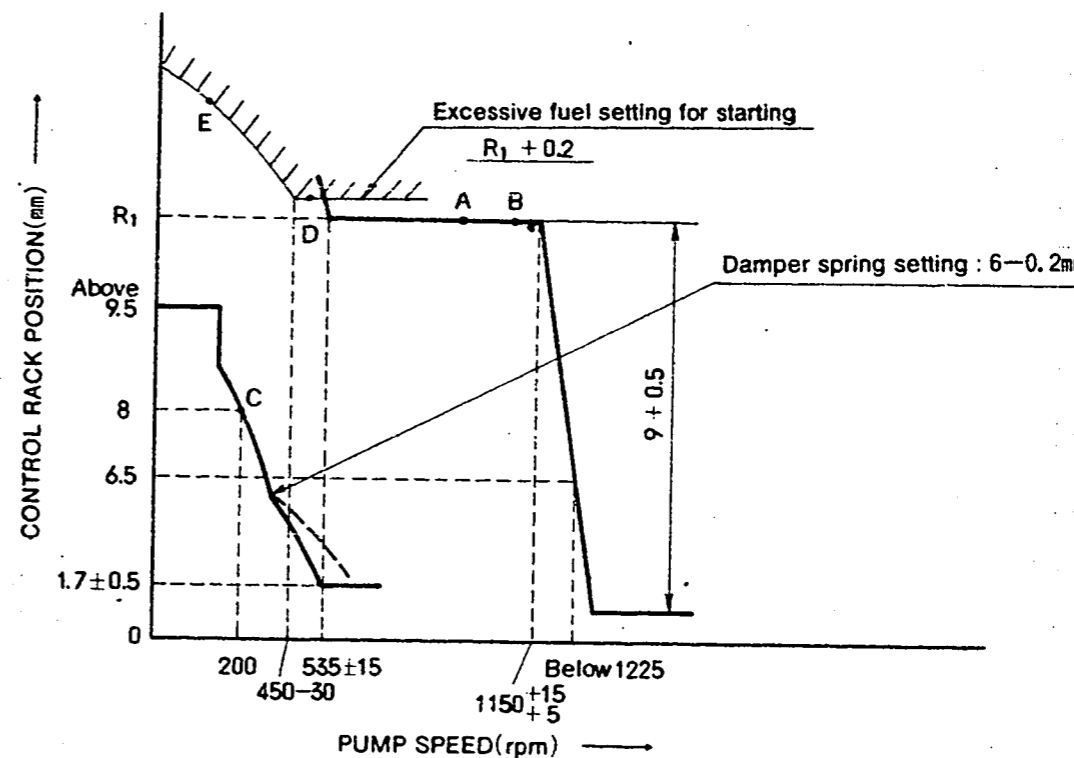

• LOAD CONTROL LEVER ANGLE

• SPEED CONTROL LEVER ANGLE

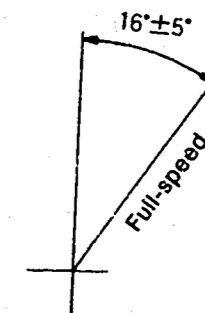
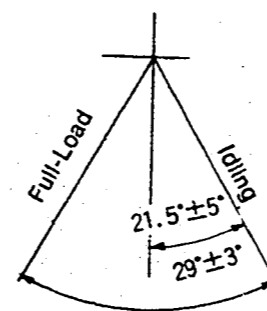

■ Note :

Before adjustment, remove the damper spring, the cover and the idling spring capsule.

■ Adjustment

Item	Pump Speed (rpm)	Rack Position (mm)	Remarks
Flyweight Lift And Full-Load Position	700~800	9.6	• Speed control lever: temporary setting.
	1300	0.1~0.2	• Adjust using screw ①.
	Decrease pump speed to 1000 rpm and adjust the high speed lift value (9.5±0.5) using screw ②.		
Idling Adjustment	520~550	1.2~2.2	• Adjust using screw ③
	200	8	• Adjust using spring capsule ①
	520~550	1.2~2.2	• Confirm
	0	Above 9.5	• Confirm
	• Confirm the control lever angle is 16.5°~26.5°.		
Damper Spring Setting	Maintain the pump speed at 200 rpm and set the control rod at the 8mm position using the control lever. Then, gradually increase the pump speed until the rod position is 6.2±0.2mm. Tighten the damper spring capsule and fix it in the position where it begins to move the rod from the 6.2±0.1mm position.		
Maximum Speed Starting Point and Speed Droop Check	Fix the load control lever in the full-load position and fix the speed control lever in the full-speed position.		
	11.55~11.65	9.6	• Adjust using screw ④
	Below 1225 Above 1250	6.5 —	• Confirm • Confirm that there is no fuel injection.
Smoke Limiter Setting	Fix the load control lever in the full-load position.		
	500 100	9.6±0.2 —	• Adjust using smoke limiter. • Confirm injection quantity at point E.

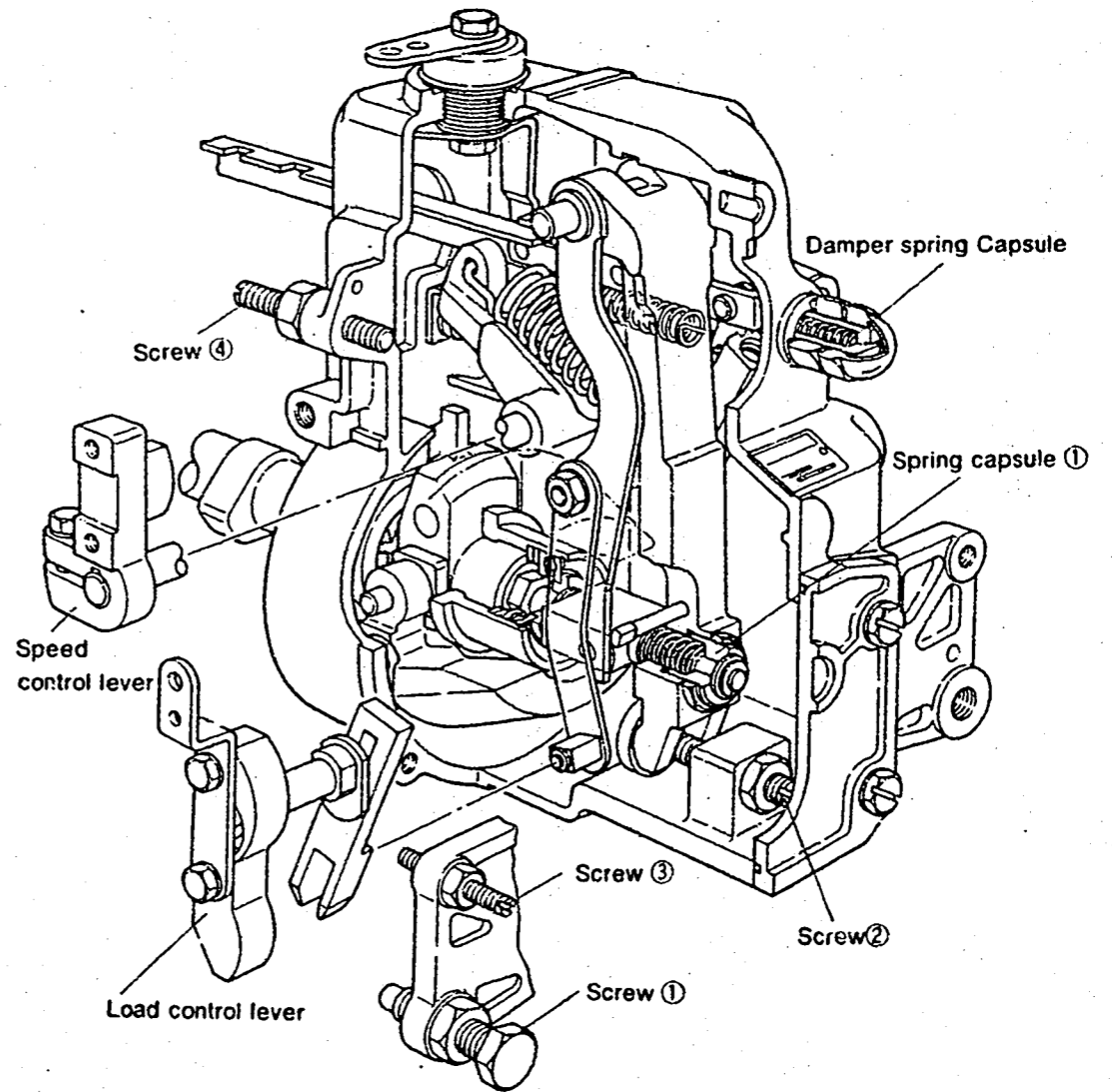

INJ. PUMP CALIBRATION DATA

ENGINE MODEL 6D22

BOSCH No.9 400 610 040
 DKKC No. 101603-1830
 Date : 20.Nov.1986 [2]
 Company : MITSUBISHI
 No. ME056440

Injection pump : PE6AD 101060-4260 Governor : EP/RFD 105490-4870 Timing device : EP/SA 105614-4100

1. Test Conditions :

Pump rotation : clockwiseviewed from drive side

Nozzle & Nozzle Holder Ass'y : 105780-0000 (BOSCH Type No.DN12SD12)
 Nozzle Holder : 105780-2080 (BOSCH Type No.EF8511/9A)
 Nozzle opening pressure : 175 Kg/cm² Transfer pump pressure : 1.6 Kg/cm²

Injection pipe : Inner Dia. 2 mm X Outer Dia. 6 mm - Length 600 mm

Test Oil : ISO4113 or SAE Standard Test Oil (SAE J967d) Oil Temp. : 40⁺⁵°C

Overflow valve opening pressure : 2.6 Kg/cm²

2. Injection Timing :

Pre-stroke : No. 1 Plunger 4.5 ±0.05mm

Note : Adjust with control rod position of mm

Injection order : 1 ~ 5 ~ 3 ~ 6 ~ 2 ~ 4 (interval : 60°±30')

Plungers are numbered from the Governor side.

Tappet clearance : Bolt adjustment type : More than 0.3mm for all cylinders.
 Shim adjustment type : Manually rotate the camshaft 2~3 times and confirm that it rotates smoothly.

4. Injection Quantity :

Adjusting Point	Rod Position (mm)	Pump Speed (r.p.m)	Injection Q'ty (cc/1000 strokes)	Max. var bet. cyl (cc)	Fixed	Remarks
	9.6	700	108.6 ~ 115.4	—	Rack	Basic Each cylinder
C	Approx. 8.0	225	15.7 ~ 21.3	—	Rack	
A	R.(9.6)	700	111.0 ~ 113.0	—	Lever	Basic
B	R.(9.6)	1,100	qA-1 ≤ qB ≤ qA+4	9	Lever	
D	R.+0.2	500	—	—	Lever	Excessive fuel setting for starting
E	—	100	120.0 ~ 160.0	—	Lever	After setting excessive fuel for starting

5. Timing Advance Specification :

Pump Speed (r.p.m)	850	800	1,000	1,150		
Advance Angle (deg.)	Start	Below 0.5	0.4~1.4	2.5~3.5	Finish 4~5	

3. GOVERNOR ADJUSTMENT

101603-1830 2/4

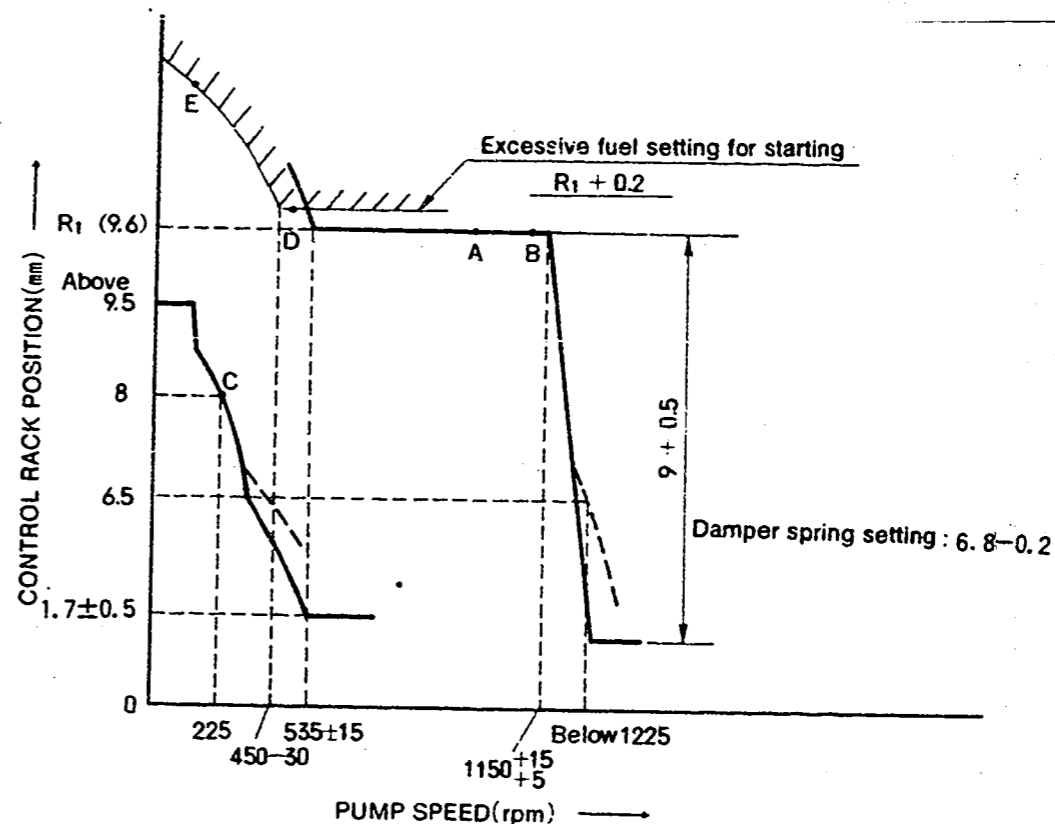

• LOAD CONTROL LEVER ANGLE

• SPEED CONTROL LEVER ANGLE

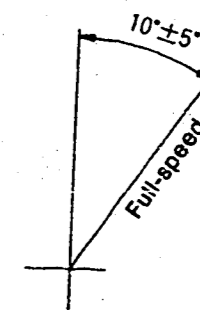
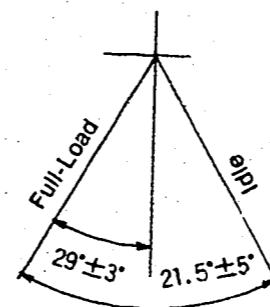

Note :

Before adjustment, remove the damper spring, the cover and the idling spring capsule.

■ Adjustment

Item	Pump Speed (rpm)	Rack Position (mm)	Remarks
Flyweight Lift And Full-Load Position	700~800	9.6	• Speed control lever: temporary setting.
	1300	0.1~0.2	• Adjust using screw ①.
Decrease pump speed to 1000 rpm and adjust the high speed lift value (9±0.5) using screw ②.			
Idling Adjustment	520~550	1.2~2.2	• Adjust using screw ③
	225	8	• Adjust using spring capsule ①
	520~550	1.2~2.2	• Confirm
	0	Above 9.5	• Confirm
• Confirm the control lever angle is 16.5°~26.5°.			
Damper Spring Setting	Maintain the pump speed at 225 rpm and set the control rod at the 8mm position using the control lever. Then, gradually increase the pump speed until the rod position is 6.8~0.2mm. Tighten the damper spring capsule and fix it in the position where it begins to move the rod from the 6.8~0.1mm position.		
Maximum Speed Starting Point and Speed Droop Check	Fix the load control lever in the full-load position and fix the speed control lever in the full-speed position.		
	1155~1165 Below 1225	9.6 6.5	• Adjust using screw ④ • Confirm • Confirm that there is no fuel injection.
Smoke Limiter Setting	Fix the load control lever in the full-load position.		
	500 100	9.6±0.2 —	• Adjust using smoke limiter. • Confirm injection quantity at point E.

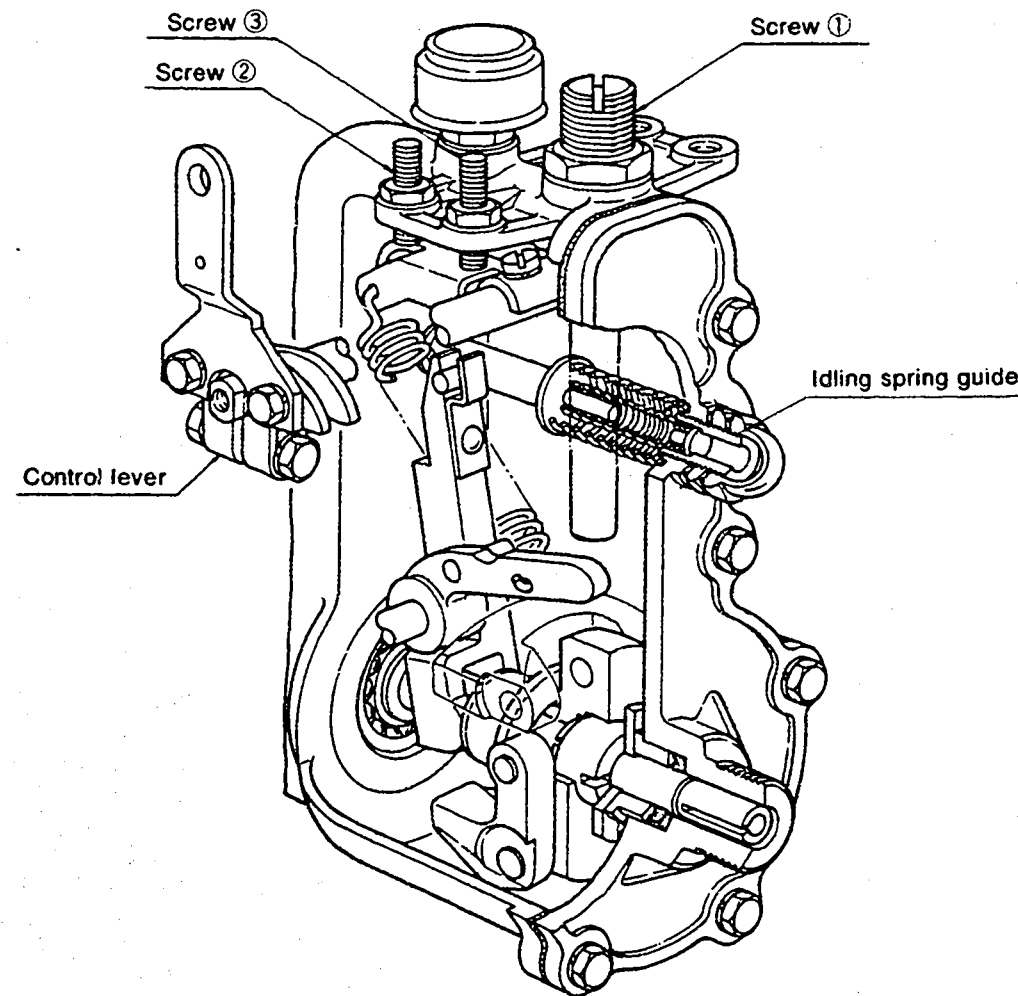

INJ. PUMP CALIBRATION DATA

BOSCH No.9 400 610 003
 DKKC No. 101631-9660
 Date : 20.Nov.1986 ③
 Company : NISSAN DIESEL
 No. 16700C6811

ENGINE MODEL SD33

Injection pump : PES6A 101063-9310 Governor : EP/RBD 105542-3610 Timing device : EP/SCD 105622-0760

1. Test Conditions :

Pump rotation : clockwise viewed from drive side

Nozzle & Nozzle Holder Ass'y : 105780-0000 (BOSCH Type No.DN12SD12) Nozzle Holder : 105780-2080 (BOSCH Type No.EF8511/9A)

Nozzle opening pressure : 175 Kg/cm² Transfer pump pressure : 1.6 Kg/cm²

Injection pipe : Inner Dia. 2 mm X Outer Dia. 6 mm - Length 600 mm

Test Oil : ISO4113 or SAE Standard Test Oil (SAE J967d) Oil Temp. : 40⁺⁵ °C

Overflow valve opening pressure : Kg/cm²

2. Injection Timing :

Pre-stroke : No. 1 Plunger 2.15 ± 0.05 mm
 Note : Adjust with control rod position of 10.7 mm

Injection order : 1 ~ 4 ~ 2 ~ 6 ~ 3 ~ 5 (interval : 60° ± 30')

Plungers are numbered from the Drive side.

Tappet clearance : Bolt adjustment type : More than 0.3mm for all cylinders.
 Shim adjustment type : Manually rotate the camshaft 2~3 times and confirm that it rotates smoothly.

4. Injection Quantity :

Adjusting Point	Rod Position (mm)	Pump Speed (r.p.m)	Injection Q'ty (cc/1000 strokes)	Max. var bet. cyl (%)	Fixed	Remarks
A	11.2	800	31.5 ~ 33.5	±2.5	Rack	Basic
B	10.7	1,900	36.0 ~ 38.2	±4	Rack	
C	Approx. 7.5	300	6.5 ~ 8.5	±15	Rack	

5. Timing Advance Specification :

Pump Speed (r.p.m)	500	550	1,100	1,500	1,900		
Advance Angle (deg.)	Below 0.5	Below 0.7	1.2~2.2	3.1~4.1	Finish 5.5~6.5		

3. GOVERNOR ADJUSTMET

101631-9660 2/4

(1) Pneumatic Governor

(2) Mechanical Governor

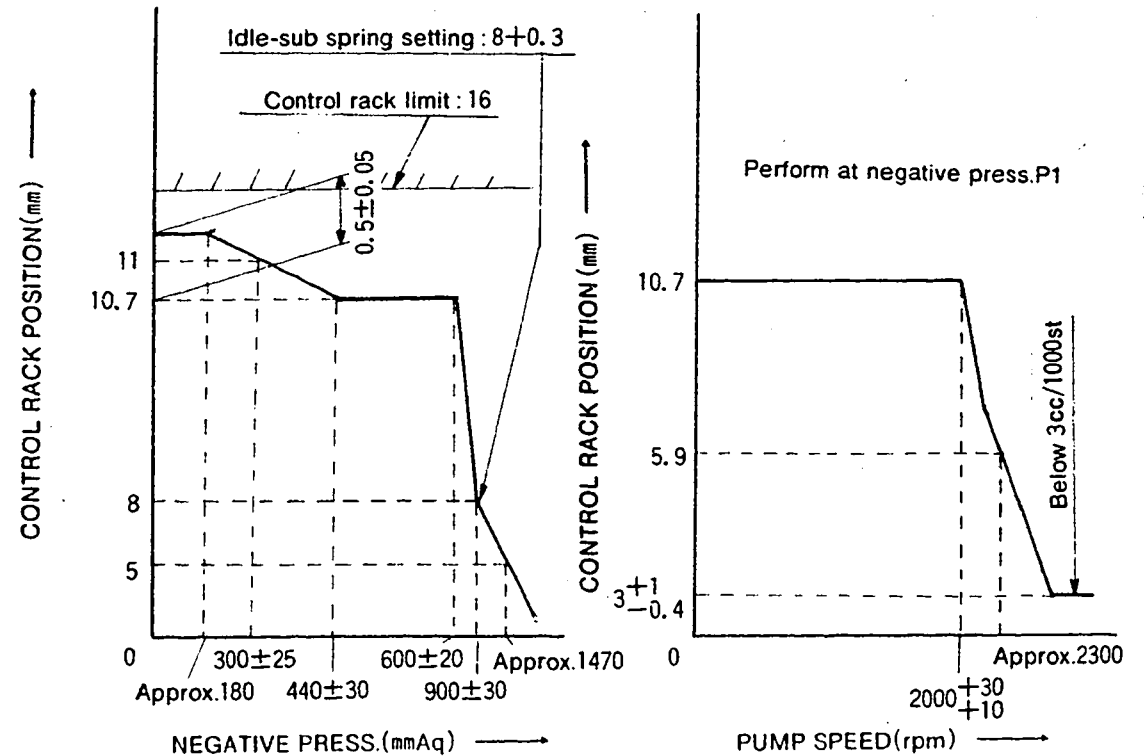

■ Air Tightness Test

1. Increase the pressure of the pneumatic governor's negative pressure chamber to 500 mmAq at a pump speed of 500 rpm and a control rack position of Approx.11.2 mm.
2. Then, confirm that it takes 10 seconds or more for the negative pressure to fall from 500 mmAq to 480 mmAq.

■ Adjustment

1. Pneumatic Governor (Pump Speed : 500 rpm)

Item	Negative Press. (mmAq)	Rack Position (mm)	Remarks
Smoke Set Screw Adjustment	0	Approx.11.2	• Adjust using spring capsule ①.
Torque Control Adjustment	Approx.180	Approx.11.2	• Adjust thickness of shim ①.
	410~470	10.7	• Adjust thickness of shim ②.
	275~325	11.0	
	—	—	• Inspection : 0.5±0.05 mm

Item	Negative Press. (mmAq)	Rack Position (mm)	Remarks
High-speed control Adjustment	580~620	10.7	• Adjust thickness of shim ③.
Idling Adjustment	870~930 Approx.1470	7.7~8.3 5.0	• Adjust using spring capsule ②. • Confirm

2. Mechanical Governor (Negative pressure: 580~620 mmAq)

Item	Pump Speed (rpm)	Rack Position (mm)	Remarks
Maximum Speed Control Adjustment	2010~2030	10.7	• Adjust using screw ①.
	Approx.2300	5.9	• Confirm
	Approx.2600	2.6~4	• Confirm (Check the fuel injection quantity:below 3 cc/1000st)

■ Timing Setting

At No.1 plunger's beginning of injection position.

Pump center line

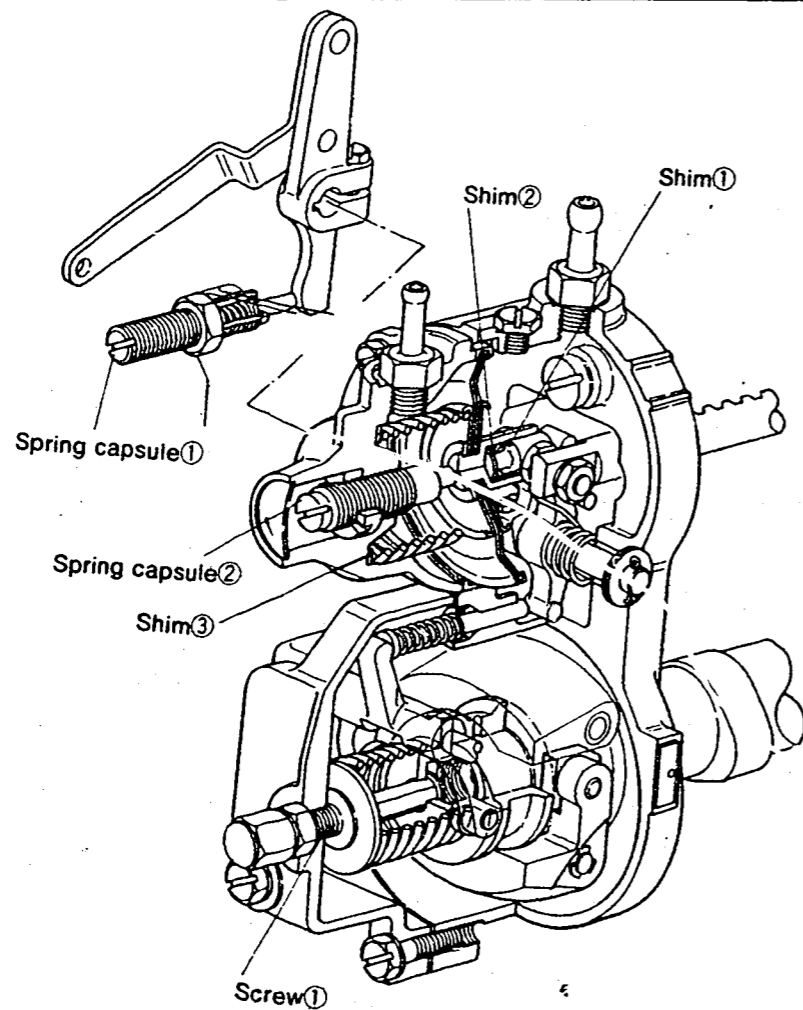
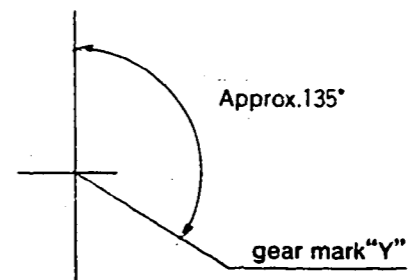

INJ. PUMP CALIBRATION DATA

ENGINE MODEL SD33

BOSCH No.9 400 610 038
 DKKC No. 101631-9661
 Date: 20.Nov.1986 ③
 Company: NISSAN DIESEL
 No. 16700C6811

Injection pump : PES6A Governor : EP/RBD Timing device : EP/SCD
 101063-9300 105542-3610 105622-0760

1. Test Conditions :

Pump rotation : clockwise viewed from drive side
 Nozzle & Nozzle Holder Ass'y : 105780-0000 (BOSCH Type No.DN12SD12) Nozzle Holder : 105780-2080 (BOSCH Type No.EF8511/9A)
 Nozzle opening pressure : 175 Kg/cm² Transfer pump pressure : 1.6 Kg/cm²
 Injection pipe : Inner Dia. 2 mm X Outer Dia. 6 mm - Length 600 mm
 Test Oil : ISO4113 or SAE Standard Test Oil (SAE J967d) Oil Temp. : 40^{±5} °C
 Overflow valve opening pressure : Kg/cm²

2. Injection Timing :

Pre-stroke : No. 1 Plunger 2.15 ±0.05mm
 Note : Adjust with control rod position of mm
 Injection order : 1 ~ 4 ~ 2 ~ 6 ~ 3 ~ 5 (interval : 60° ±30°)
 Plungers are numbered from the Drive side.
 Tappet clearance : Bolt adjustment type : More than 0.3mm for all cylinders.
 Shim adjustment type : Manually rotate the camshaft 2~3 times and confirm that it rotates smoothly.

4. Injection Quantity :

Adjusting Point	Rod Position (mm)	Pump Speed (r.p.m)	Injection Q'ty (cc/1000 strokes)	Max. var bet. cyl (%)	Fixed	Remarks
A	11.2	800	31.5 ~ 33.5	±2.5	Rack	Basic
B	10.7	1,900	36.0 ~ 38.2	±4	Rack	
C	Approx. 7.5	300	6.5 ~ 8.5	±15	Rack	

5. Timing Advance Specification :

Pump Speed (r.p.m)	500	550	1,100	1,500	1,900		
Advance Angle (deg.)	Below 0.5	Below 0.7	1.2~2.2	3.1~4.1	Finish 5.5~6.5		

3. GOVERNOR ADJUSTMET

101631-9661 2/4

(1) Pneumatic Governor

(2) Mechanical Governor

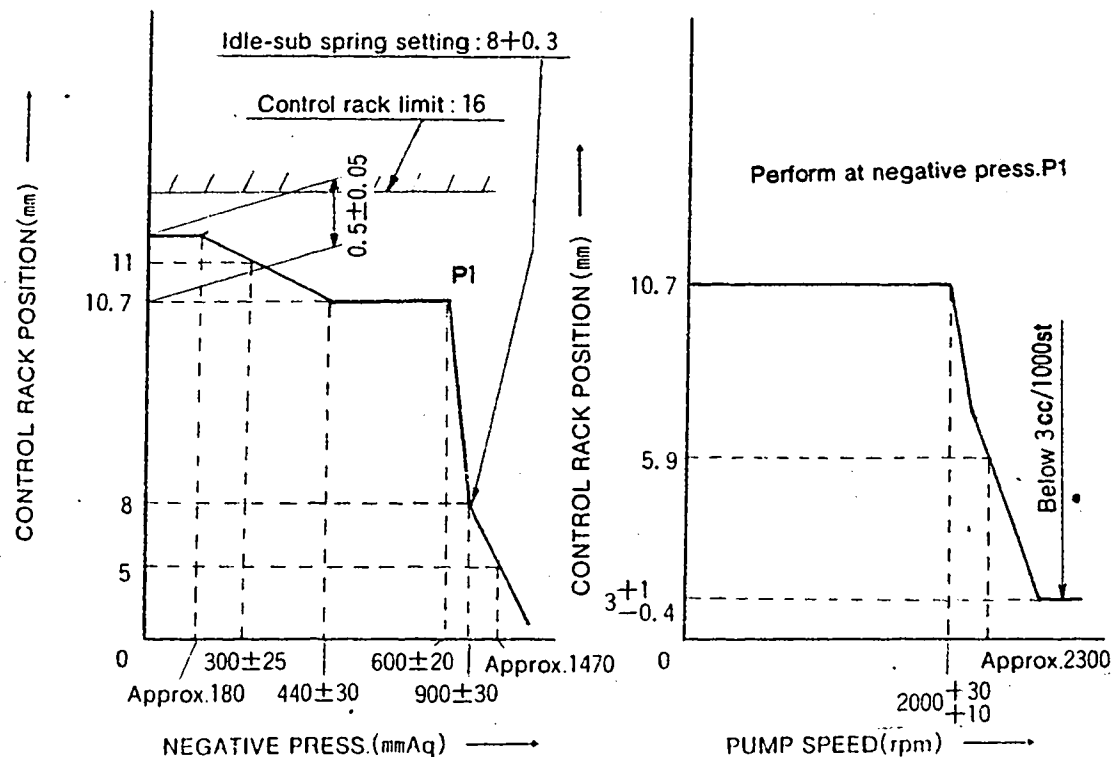

■ Air Tightness Test

1. Increase the pressure of the pneumatic governor's negative pressure chamber to 500 mmAq at a pump speed of 500 rpm and a control rack position of Approx.11.2 mm.
2. Then, confirm that it takes 10 seconds or more for the negative pressure to fall from 500 mmAq to 480 mmAq.

■ Adjustment

1. Pneumatic Governor (Pump Speed : 500 rpm)

Item	Negative Press. (mmAq)	Rack Position (mm)	Remarks
Smoke Set Screw Adjust-ment	0	Approx.11.2	• Adjust using spring capsule ①.
Torque Control Adjustment			
① Start of torque control spring movement	Approx.180	Approx.11.2	• Adjust thickness of shim ①.
② End of torque control spring movement	410~470	10.7	• Adjust thickness of shim ②.
③ Confirm	275~325	11.0	
④ Confirm torque control siroke	---	---	• Inspection : 0.5 ± 0.05 mm

Item	Negative Press. (mmAq)	Rack Position (mm)	Remarks
High-speed control Adjustment	580~620	10.7	• Adjust thickness of shim ③.
Idling Adjustment	870~930 Approx.1470	7.7~8.3 5.0	• Adjust using spring capsule ②. • Confirm

2. Mechanical Governor (Negative pressure: 580~620 mmAq)

Item	Pump Speed (rpm)	Rack Position (mm)	Remarks
Maximum Speed Control Adjustment	2010~2030	10.7	• Adjust using screw ①.
	Approx.2300	5.9	• Confirm
	Approx.2600	2.6~4	• Confirm (Check the fuel injection quantity: below 3 cc/1000st)

■ Timing Setting

At No.1 plunger's beginning of injection position.

Pump center line

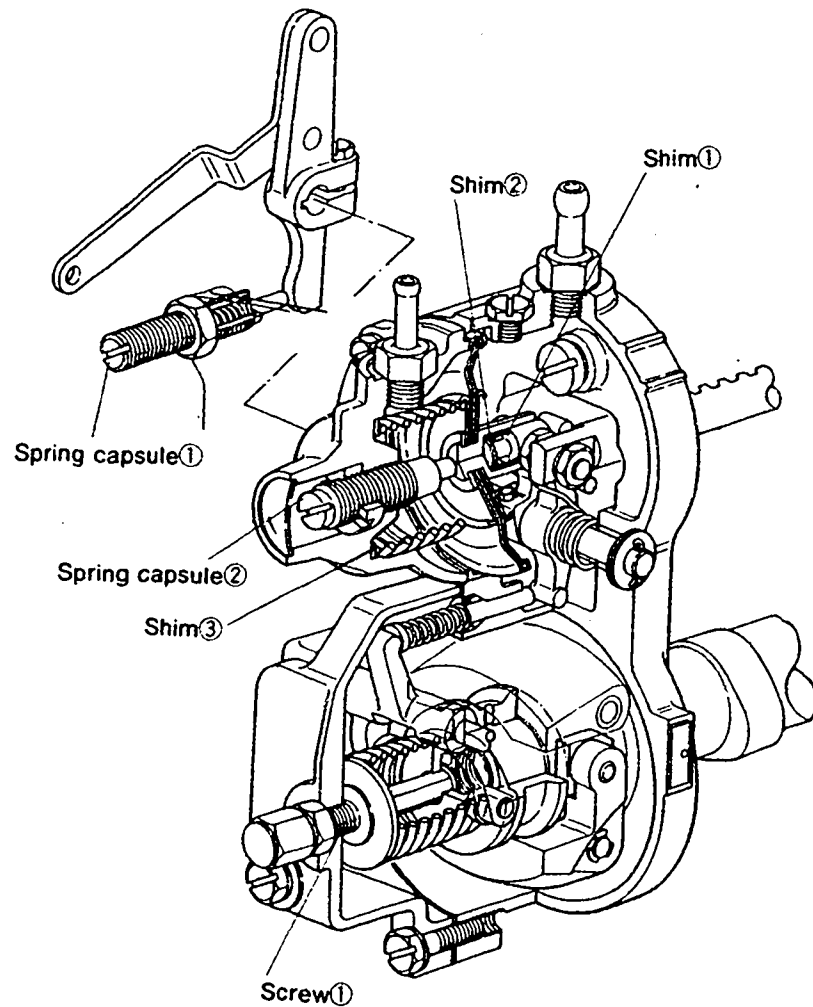
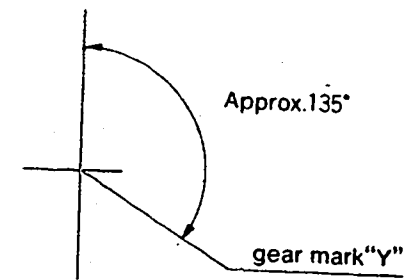

INJ. PUMP CALIBRATION DATA

ENGINE MODEL SD33

BOSCH No. 9 400 610 046
 DKKC No. 101631-9772
 Date: 20.Nov.1986 [1]
 Company: NISSAN DIESEL
 No. 16700C8605

Injection pump : PES6A 101063-9370 Governor : EP/RBD 105542-4270 Timing device : EP/SCD 105622-1100

1. Test Conditions :

Pump rotation : clockwise viewed from drive side
 Nozzle & Nozzle Holder Ass'y : 105780-0000 (BOSCH Type No.DN12SD12) Nozzle Holder : 105780-2080 (BOSCH Type No.EF8511/9A)
 Nozzle opening pressure : 175 Kg/cm² Transfer pump pressure : 1.6 Kg/cm²
 Injection pipe : Inner Dia. 2 mm X Outer Dia. 6 mm - Length 600 mm
 Test Oil : ISO4113 or SAE Standard Test Oil (SAE J967d) Oil Temp. : 40⁺5 °C
 Overflow valve opening pressure : Kg/cm²

2. Injection Timing :

Pre-stroke : No. 1 Plunger 2.15 ±0.05mm
 Note : Adjust with control rod position of mm
 Injection order : 1 $\frac{60^{\circ} \pm 30^{\circ}}{300^{\circ} \pm 30^{\circ}}$ 4, 1 $\frac{120^{\circ} \pm 30^{\circ}}{300^{\circ} \pm 30^{\circ}}$ 2, 1 $\frac{180^{\circ} \pm 30^{\circ}}{300^{\circ} \pm 30^{\circ}}$ 6, 1 $\frac{240^{\circ} \pm 30^{\circ}}{300^{\circ} \pm 30^{\circ}}$ 3, 1 $\frac{300^{\circ} \pm 30^{\circ}}{300^{\circ} \pm 30^{\circ}}$ 5 (interval : °±30°)
 Plungers are numbered from the Drive side.
 Tappet clearance : Bolt adjustment type : More than 0.3mm for all cylinders.
 : Shim adjustment type : Manually rotate the camshaft 2~3 times and confirm that it rotates smoothly.

4. Injection Quantity :

Adjusting Point	Rod Position (mm)	Pump Speed (r.p.m)	Injection Q'ty (cc/1000 strokes)	Max. var bet. cyl (%)	Fixed	Remarks
	12.2	800	31.1 ~ 33.1	±2.5	Rack	Basic
	11.7	1,900	34.5 ~ 37.7	±4	Rack	
	Approx. 7.8	300	6.5 ~ 8.5	±15	Rack	Control rack limit

5. Timing Advance Specification :

Pump Speed (r.p.m)	500	1,100	1,900			
Advance Angle (deg.)	Below 0.5	1.2~2.2	Finish 5.5~6.5			

3. GOVERNOR ADJUSTMET

101631-9772 2/4

(1)Pneumatic Governor

(2)Mechanical Governor

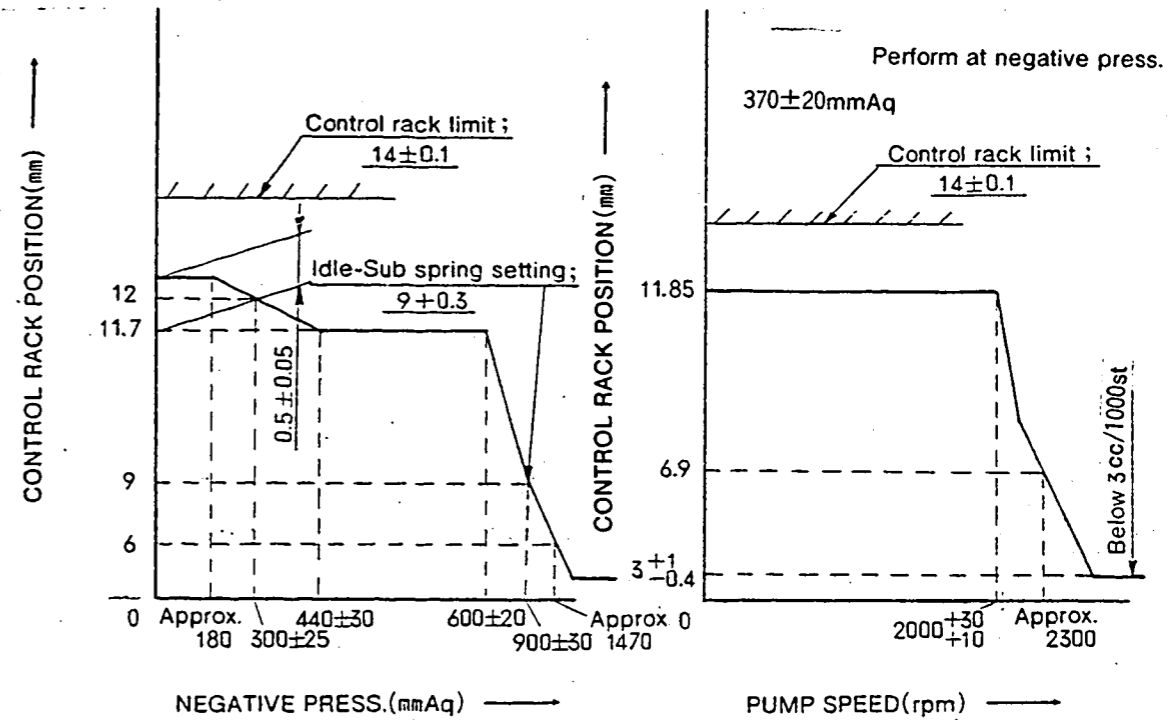

■ Air Tightness Test

1. Increase the pressure of the pneumatic governor's negative pressure chamber to 500 mmAq at a pump speed of 500 rpm and a control rack position of Approx.12.2 mm.
2. Then, confirm that it takes 10 seconds or more for the negative pressure to fall from 500 mmAq to 480 mmAq.

■ Adjustment

1. Pneumatic Governor (Pump Speed : 500 rpm)

Item	Negative Press. (mmAq)	Rack Position (mm)	Remarks	
Smoke Set Screw Adjustment	0	Approx.12.2	• Adjust using spring capsule ①.	
Torque Control Adjustment				
	①Start of torque control spring movement	Approx.180	Approx.12.2	• Adjust thickness of shim ①.
	②End of torque control spring movement	410~470	11.7	• Adjust thickness of shim ②.
	③Confirm	275~325	12.0	
④Confirm torque control stroke	—	—	• Inspection : 0.5±0.05 mm	

Item	Negative Press. (mmAq)	Rack Position (mm)	Remarks
High-speed control Adjustment	580~620	11.7	• Adjust thickness of shim ③.
Idling Adjustment	870~930 Approx.1470	8.7~9.3 6.0	• Adjust using spring capsule ②. • Confirm

■ Timing Setting

At No.1 plunger's beginning of injection position.

B.T.D.C. : 20°

Pump center line

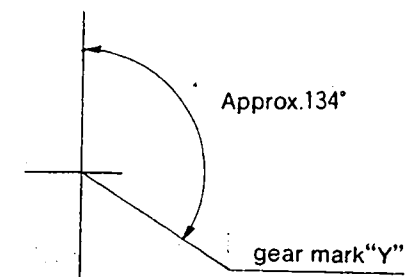

2. Mechanical Governor (Negative pressure: 350~390 mmAq)

Item	Pump Speed (rpm)	Rack Position (mm)	Remarks
Maximum Speed Control Adjustment	2010~2030	11.85	• Adjust using screw ①.
	Approx.2300	6.9	• Confirm
	Approx.2600	Below 3	• Confirm (Check the fuel injection quantity:below 3 cc/1000s†)

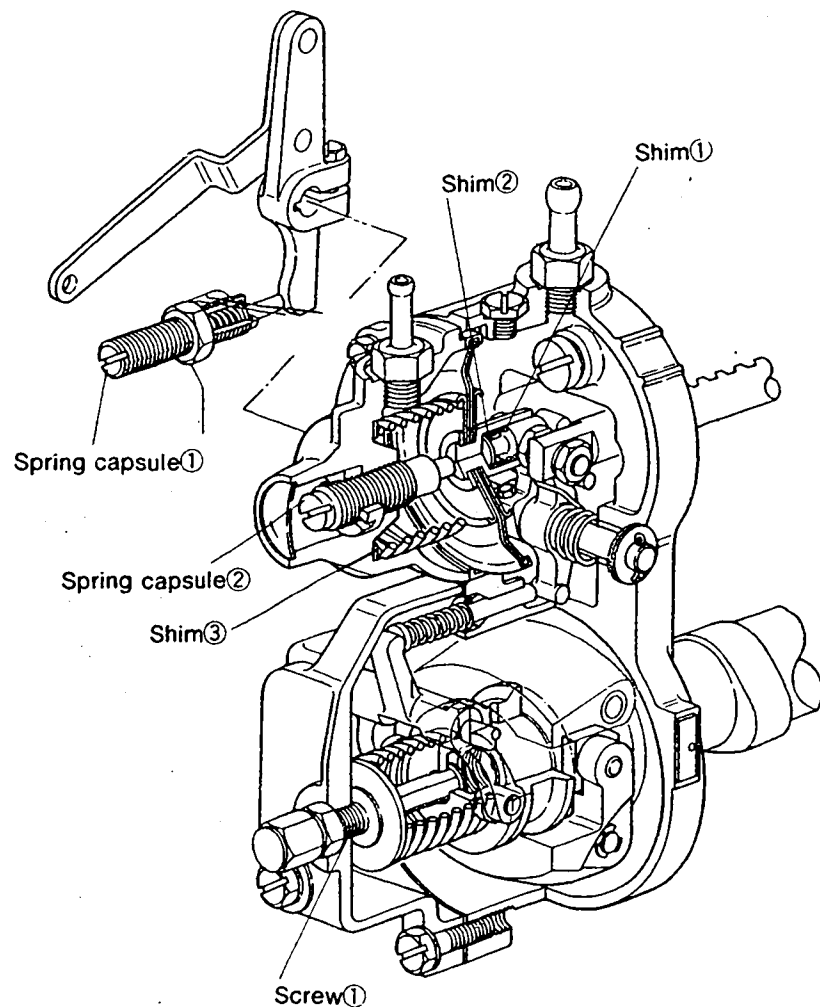

INJ. PUMP CALIBRATION DATA

ENGINE MODEL SD33

BOSCH No.9 400 610 047
 DKKC No. 101631-9841
 Date: 20.Nov.1986 5
 Company: NISSAN DIESEL
 No. 16700C8608

3. GOVERNOR ADJUSTMET

101631-9841 2/5

Injection pump : PES6A Governor : Timing device : EP/SCD
 101063-9370 105622-1100

1. Test Conditions :

Pump rotation : clockwiseviewed from drive side

Nozzle & Nozzle Holder Ass'y : 105780--0000 (BOSCH Type No.DN12SD12)
 Nozzle Holder : 105780--2080 (BOSCH Type No.EF8511/9A)
 Nozzle opening pressure : 175 Kg/cm² Transfer pump pressure : 1.6 Kg/cm²

Injection pipe : Inner Dia. 2 mm X Outer Dia. 6 mm - Length 600 mm

Test Oil : ISO4113 or SAE Standard Test Oil (SAE J967d) Oil Temp. : 40⁺5 °C

Overflow valve opening pressure : Kg/cm²

2. Injection Timing :

Pre-stroke : No. 1 Plunger 2.15 ±0.05mm
 Note : Adjust with control rod position of mm

Injection order : 1 ~ 4 ~ 2 ~ 6 ~ 3 ~ 5 (interval : 60° ±30')

Plungers are numbered from the Drive side.

Tappet clearance : Bolt adjustment type ; More than 0.3mm for all cylinders.
 ; Shim adjustment type ; Manually rotate the camshaft 2~3 times and confirm that it rotates smoothly.

4. Injection Quantity :

Adjust- ing Point	Rod Position (mm)	Pump Speed (r.p.m)	Injection Q'ty (cc/1000 strokes)	Max. var bet. cyl (%)	Fixed	Remarks
	12.2	800	31.1 ~ 33.1	±2.5	Rack	Basic
	11.7	1,900	34.5 ~ 37.7	±4	Rack	
	Approx. 7.8	300	6.5 ~ 8.5	±15	Rack	

5. Timing Advance Specification :

Pump Speed (r.p.m)	500	1,100	1,900			
Advance Angle (deg.)	Below 0.5	1.2~2.2	Finish 5.5~6.5			

(1)Pneumatic Governor

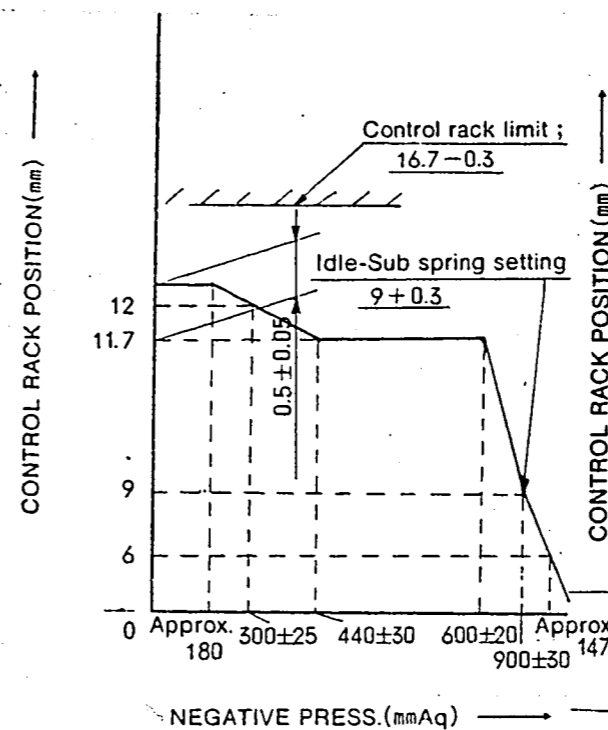

(2)Mechanical Governor

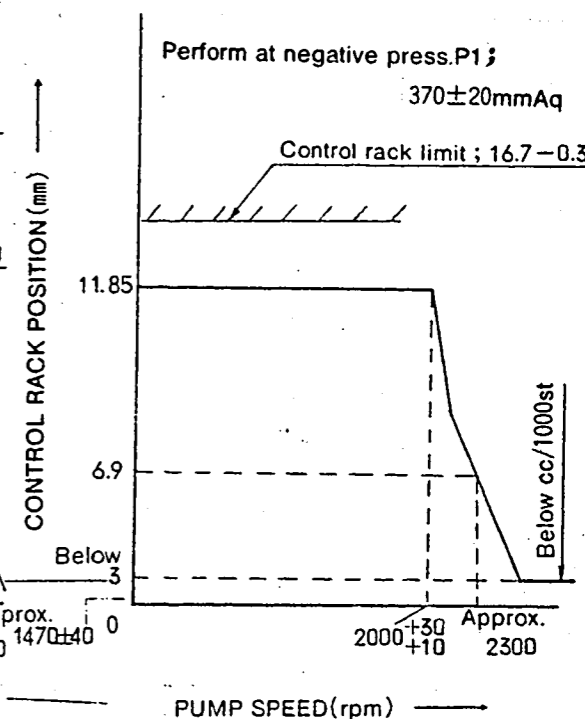

■ Air Tightness Test

1. Increase the pressure of the pneumatic governor's negative pressure chamber to 500 mmAq at a pump speed of 500 rpm and a control rack position of approx.12.2 mm.
2. Then, confirm that it takes 10 seconds or more for the negative pressure to fall from 500 mmAq to 480 mmAq.

■ Adjustment

1. Pneumatic Governor (Pump Speed : 500 rpm)

Item	Negative Press. (mmAq)	Rack Position (mm)	Remarks
Smoke Set Screw Adjust- ment	0	Approx.12.2	• Adjust using spring capsule ①.
Torque Control Adjustment ①Start of torque control spring movement	Approx.180	Approx.12.2	• Adjust thickness of shim ①.
②End of torque control spring movement	410~470	11.7	• Adjust thickness of shim ②.
③Confirm	275~325	12	
④Confirm torque control stroke	—	—	• Inspection : 0.5±0.05 mm

Item	Negative Press. (mmAq)	Rack Position (mm)	Remarks
High-speed control Adjustment	580~620	11.7	• Adjust thickness of shim ③.
Idling Adjustment	870~930 Approx.1470	8.7~9.3 6.0	• Adjust using spring capsule ②. • Confirm

2. Mechanical Governor (Negative pressure: 350~390 mmAq)

Item	Pump Speed (rpm)	Rack Position (mm)	Remarks
Maximum Speed Control Adjustment	2010~2030	11.85	• Adjust using screw ①.
	Approx.2300	6.9	• Confirm
	Approx.2600	2.6~4	• Confirm (Check the fuel injection quantity: below 3 cc/1000st)

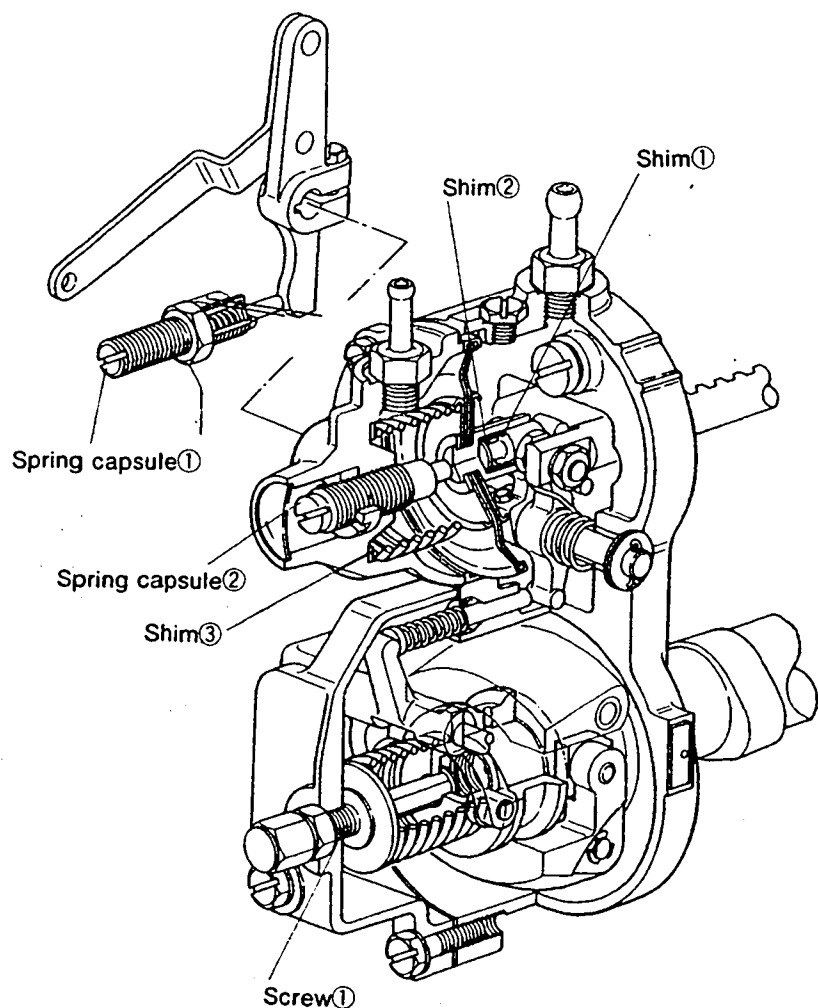

(3) Aneroid Compensator Adjustment

- Adjust using the setting screw so that the clearance between the housing and snap ring is to 0.1 ~ 0.5 mm.

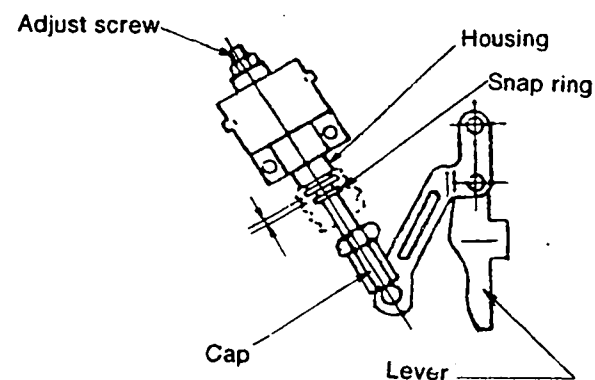

- Attach the aneroid compensator assembly to the bracket.
- Maintain the pump speed at 500 rpm after adjustment of the RBD governor.
- Confirm the control rod positions (12.2 mm and 11.7 mm) by the decreasing pressure of the pneumatic governor gradually from 0.
- Loosen the cap and then screw it in until it just contacts the control lever pin.
- Maintain the pump speed at 1000 rpm and reduce the pressure of the pneumatic governor's negative pressure chamber to 500 mmAq.
- Adjust the cap so that the control rack moves 0.01 to 0.05 mm from the 11.7 mm position in the "fuel-decrease" direction and then secure with the nut.
- Maintain the pump speed at 1000 rpm and reduce the pressure of the pneumatic governor's negative pressure chamber to 500 mmHg.
- Ensure that the control rack moves to the 11.65, 11.2±0.2 and 10.9±0.2 mm positions when the aneroid compensator pressure is reduced to 70-40, 135 and 164 mHg respectively.

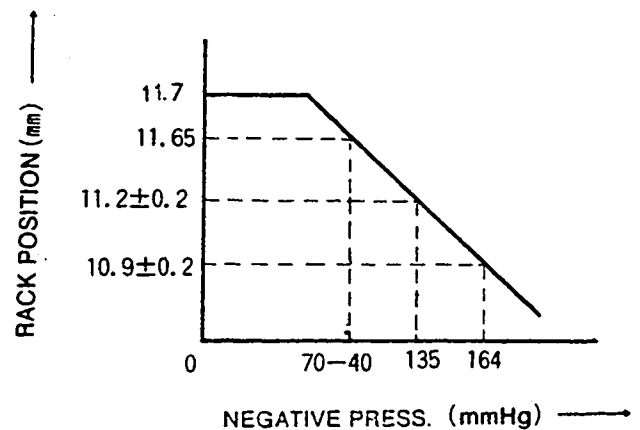

- Readjust the setting screw if the performance of the aneroid compensator is not as specified.

101631-9841 5/5

■ Timing Setting

At No.1 plunger's beginning of injection position.

B.T.D.C. : 20°

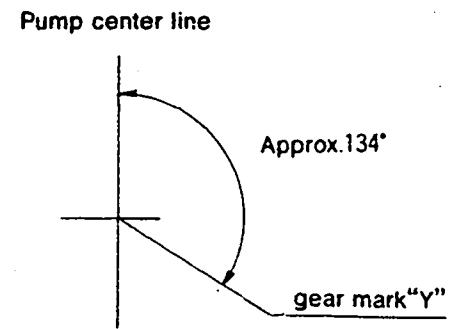

Approx. 134°
gear mark "Y"

INJ. PUMP CALIBRATION DATA

ENGINE MODEL SD33T

BOSCH No.9 400 610 004
 DKKC No. 101641-9122
 Date : 20.Nov.1986 [6]
 Company : NISSAN DIESEL
 No. 16700C8700

Injection pump : PES6A Governor : EP/RLD Timing device : EP/SCD
 101064-9050 105931-1520 105622-1120

1. Test Conditions :

Pump rotation : clockwiselooked from drive side

Nozzle & Nozzle Holder Ass'y : 105780-0000 (BOSCH Type No.DN12SD12)
 Nozzle Holder : 105780-2080 (BOSCH Type No.EF8511/9A)
 Nozzle opening pressure : 175 Kg/cm² Transfer pump pressure : 1.6 Kg/cm²

Injection pipe : Inner Dia. 2 mm X Outer Dia. 6 mm - Length 600 mm

Test Oil : ISO4113 or SAE Standard Test Oil (SAE J967d) Oil Temp. : 40^{±5}°C

Overflow valve opening pressure : Kg/cm²

2. Injection Timing :

Pre-stroke : No. 1 Plunger 2.3 ±0.05mm
 Note : Adjust with control rod position of mm

Injection order : 1 ~ 4 ~ 2 ~ 6 ~ 3 ~ 5 (interval : 60° ±30')
 Plungers are numbered from the Drive side.

Tappet clearance : Bolt adjustment type : More than 0.3mm for all cylinders.
 Shim adjustment type : Manually rotate the camshaft 2~3 times and confirm that it rotates smoothly.

4. Injection Quantity :

Adjusting Point	Rod Position (mm)	Pump Speed (r.p.m)	Injection Q'ty (cc/1000 strokes)	Max. var bet. cyl (%)	Fixed	Remarks
A	13.7	1,000	47.2 ~ 49.4	±2	Rack	Basic
H	Approx. 9.9	360	6.4 ~ 8.6	±15	Rack	
A	R ₁ (13.7)	1,000	47.2 ~ 49.4	-	Lever	Basic Boost press. Above 400mmHg
B	R ₁ -0.7	2,000	45.2 ~ 49.2	-	Lever	Boost press. Above 400mmHg
C	R ₂ (12.7)	500	32.6 ~ 36.6	-	Lever	Boost press.0
I	(15.8)	100	67.0	-	Lever	Control rack limit

5. Timing Advance Specification :

Pump Speed (r.p.m)	550	500	1,200	1,900
Advance Angle (deg.)	Start	Below 0.5	1.7~2.7	Finish 5.5~6.5

3. GOVERNOR ADJUSTMENT

101641-9122 2/5

CONTROL LEVER ANGLE

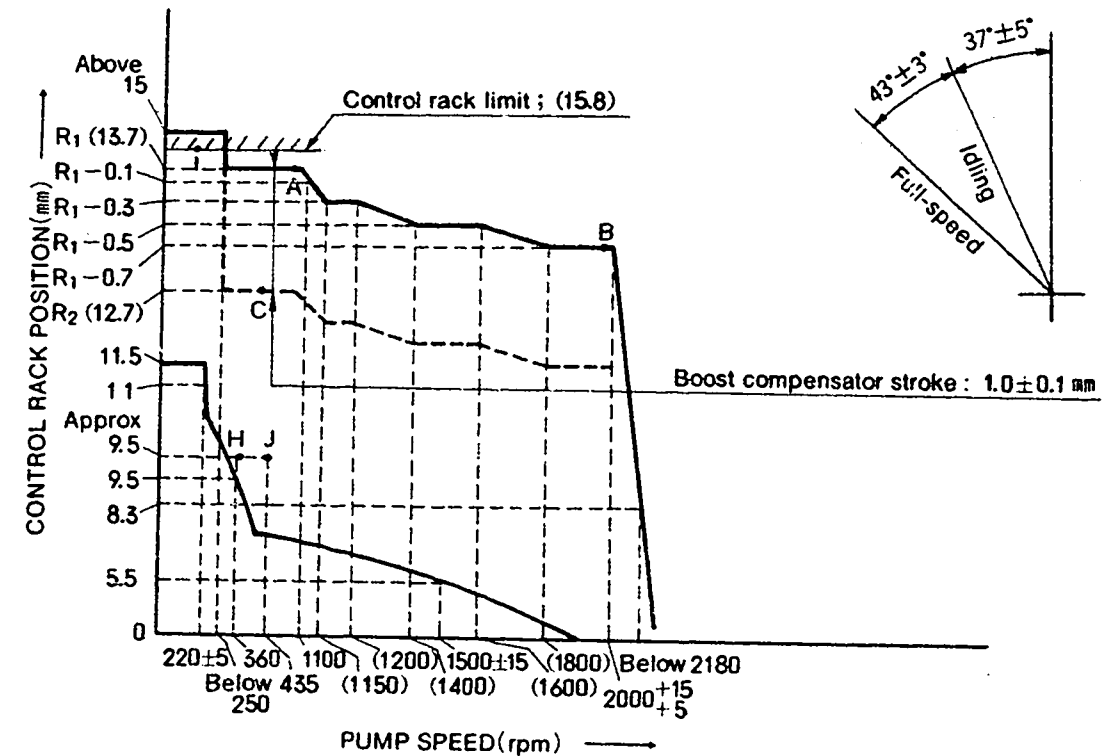

Idling Adjustment

Item	Pump Speed (rpm)	Rack Position (mm)	Remarks
Idling Lever Position: Temporary Setting	80~100	11.5	• Adjust using screw ①.
Idling Position Setting	360 215~225	9.5 11	• Adjust using spring capsule ①.
Governor Spring Contact Adjustment	1285~1315	5.5	• Adjust the governor shaft position. • Confirm
Setting the Idling Lever Position	360	Approx.9.5	• Adjust using screw ①. • Confirm the control lever angle (32°~42°)

■ Full Load Adjustment (Torque Cam No. 74)

Item	Pump Speed (rpm)	Rack Position (mm)	Remarks
Full Speed Lever Position: Temporary Setting	Approx.2000	(13.7)-0.7	• Adjust using screw ③. (Do not enter governor control range)
Full Load Position Adjustment	1000	13.7	• Adjust using screw ④.
Torque Cam Position Adjustment	1100	(13.7)-0.1	• Adjust using screw ⑤.
	(1150)	(13.7)-0.3	• Confirm
	(1200)	(13.7)-0.3	• "
	(1400)	(13.7)-0.5	• "
	(1600)	(13.7)-0.5	• "
	(1800)	(13.7)-0.7	• "
	—	—	• "
Confirm injection quantity at points A to B.			
Maximum Speed control Adjustment	2005~2015	(13.7)-0.7	• Adjust using screw ③.
	Below 2180	8.5	• Confirm • After adjustment, confirm that the control lever angle is 40°~46°
Confirming Excess Fuel Limit for Engine Starting	435	Approx.9.5	• Set the control lever at point J.
	0	11.5	• Confirm
	0	Above 15	• Move the control lever to the "full-speed" position and then confirm the control rack position.
Confirm the Black Smoke Limit	Fix the control lever at point H. Then, operate the pump at 250 rpm. Confirm that the control rack does not move beyond 13.7 mm. When the control lever is moved to the "full-speed" position again increase the pump speed and confirm that the control rack starts to move from a pump speed of — rpm.		
Rack Limiter Adjustment	0	(15.9)	• Fix the control rack using screw Part No. 157954-3700
	Measure the depth of the control rack cap. Then, adjust screw ⑥ so that it equals the depth of the rack cap and install the rack cap. Confirm injection quantity at point I.		

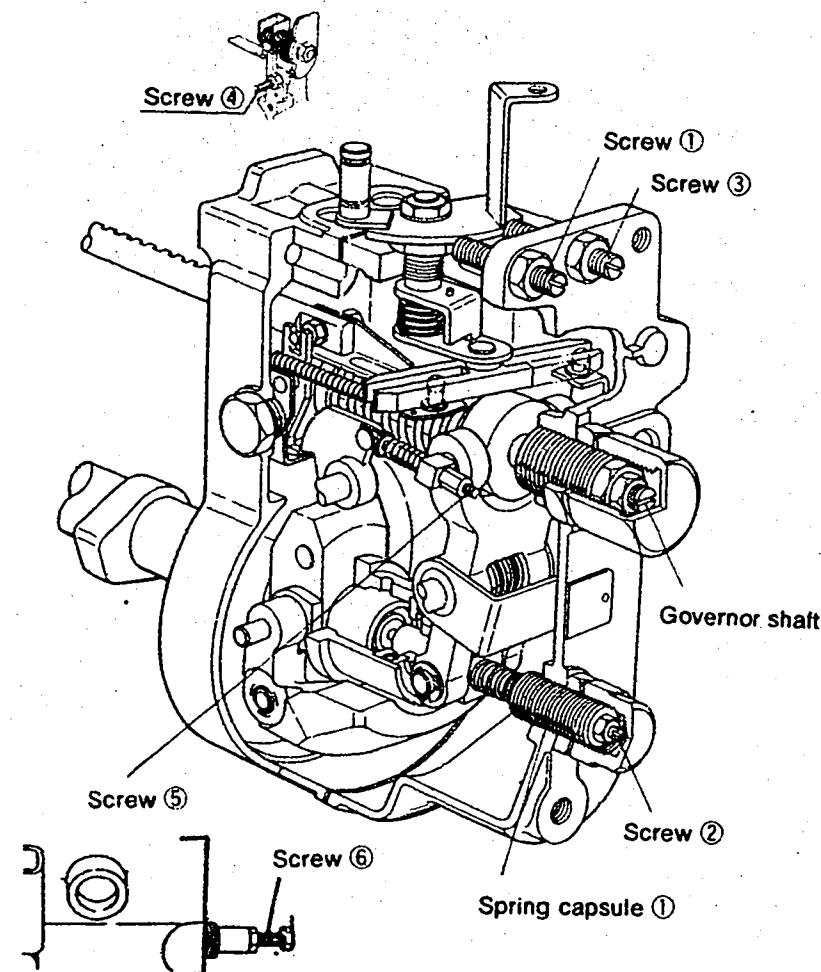

■ Boost Compensator Adjustment

- Maintain the pump speed at 700 rpm and fix the control lever in the full load position.
- In this condition, use calipers to measure the dimension "L" of the pushrod from the end face of the spacer. (Inspection: 23.9 to 24.1 mm)

Item	Pump Speed (rpm)	Rack Position (mm)	Remarks
Setting the Boost Compensator Spring Force	95~135	12.7	• Adjust using screw ⑦.
Boost Compensator Spring Adjustment (Boost compensator stroke: 1.0±0.1 mm)	0	13.7~12.7	• Adjust using screw ⑦.
	95~135	12.7	• Confirm
	300~350	13.7	• Confirm

101641-9122 5/5

BOOST COMPENSATOR ADJUSTMENT

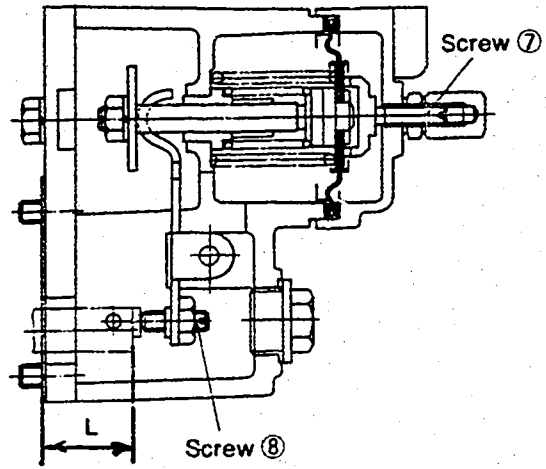
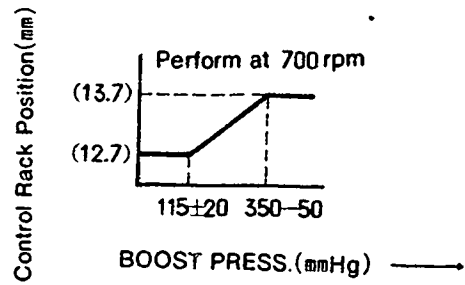

■ Timing Setting

At No. 1 plunger's beginning of injection position.
B.D.T.C. : 20

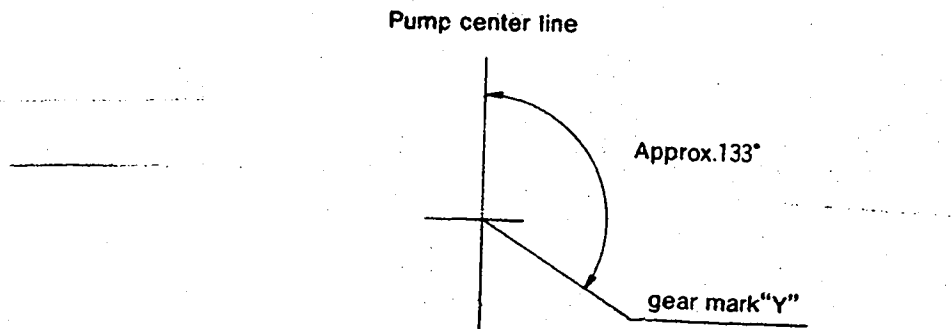

INJ. PUMP CALIBRATION DATA

ENGINE MODEL SD33T

BOSCH No.9 400 610 005
 DKKC No. 101641-9132
 Date : 20.Nov.1986 [6]
 Company : NISSAN DIESEL
 No. 16700C8701

Injection pump : PES6A Governor : EP/RLD Timing device : EP/SCD
 101064-9040 105931-1520 105622-1120

1. Test Conditions :

Pump rotation : clockwise viewed from drive side

Nozzle & Nozzle Holder Ass'y : 105780-0000 (BOSCH Type No.DN12SD12)
 Nozzle Holder : 105780-2080 (BOSCH Type No.EF8511/9A)
 Nozzle opening pressure : 175 Kg/cm² Transfer pump pressure : 1.6 Kg/cm²

Injection pipe : Inner Dia. 2 mm X Outer Dia. 6 mm - Length 600 mm

Test Oil : ISO4113 or SAE Standard Test Oil (SAE J967d) Oil Temp. : 40^{±5}°C

Overflow valve opening pressure : Kg/cm²

2. Injection Timing :

Pre-stroke : No. 1 Plunger 2.3 ±0.05mm
 Note : Adjust with control rod position of mm

Injection order : 1 ~ 4 ~ 2 ~ 6 ~ 3 ~ 5 (interval : 60° ±30°)
 Plungers are numbered from the Drive side.

Tappet clearance : Bolt adjustment type : More than 0.3mm for all cylinders.
 Shim adjustment type : Manually rotate the camshaft 2~3 times and confirm that it rotates smoothly.

4. Injection Quantity :

Adjusting Point	Rod Position (mm)	Pump Speed (r.p.m)	Injection Q'ty (cc/1000 strokes)	Max. var bet. cyl (%)	Fixed	Remarks
	13.7	1,000	46.7 ~ 48.9	±2	Rack	Basic
H	Approx. 9.9	360	6.4 ~ 8.6	±15	Rack	
A	R ₁ (13.7)	1,000	46.7 ~ 48.9	—	Lever	Basic Boost press. Above 400mmHg
B	R ₁ -0.7	2,000	46.7 ~ 50.7	—	Lever	Boost press. Above 400mmHg
C	R ₂ (12.7)	500	33.7 ~ 37.7	—	Lever	Boost press. 0
I	(15.8)	100	57.0 ~ 67.0	—	Lever	Control rack limit

5. Timing Advance Specification :

Pump Speed (r.p.m)	Below 550	500	1,200	1,900		
Advance Angle (deg.)	Start	Below 0.5	1.7~2.7	Finish 5.5~6.5		

3. GOVERNOR ADJUSTMENT

101641-9132 2/5

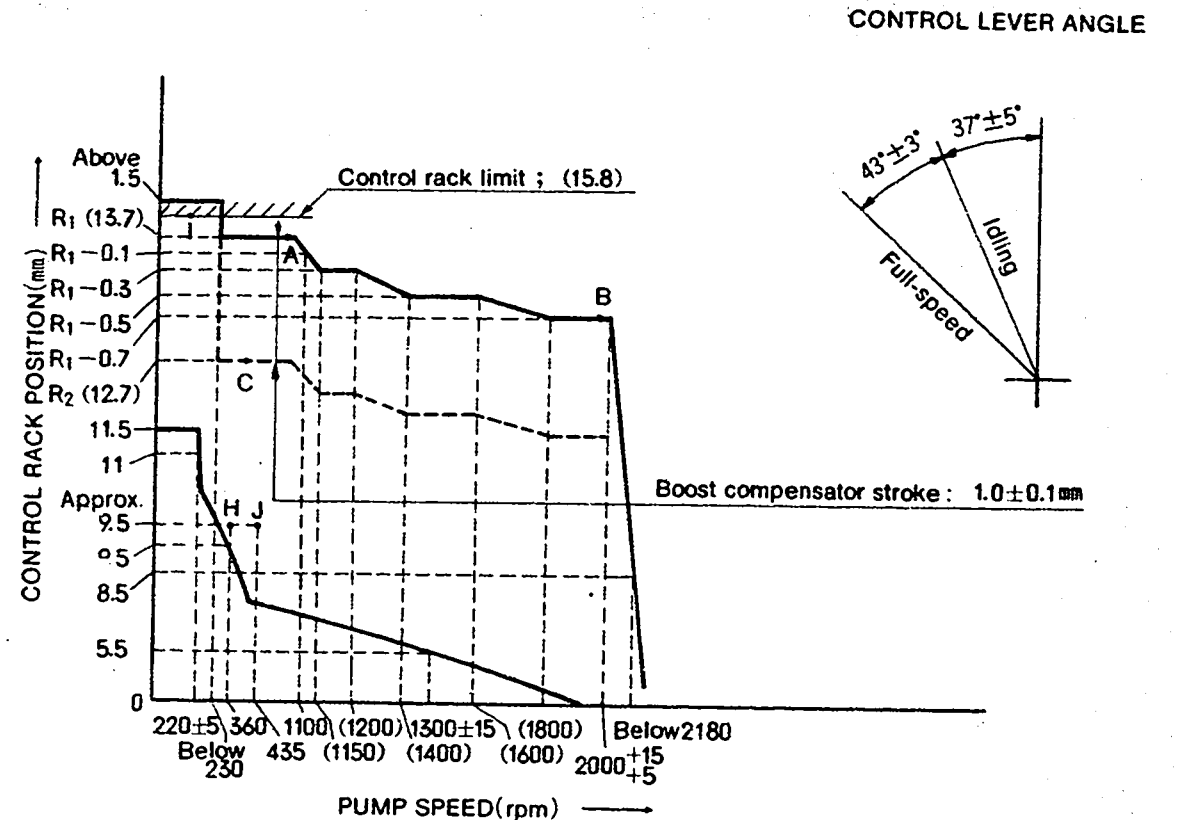

Idling Adjustment

Item	Pump Speed (rpm)	Rack Position (mm)	Remarks
Idling Lever Position: Temporary Setting	80~100	11.5	• Adjust using screw ①.
Idling Position Setting	360 215~225	9.5 11	• Adjust using spring capsule ①. • Adjust using screw ②.
Governor Spring Contact Adjustment	1285~1315	5.5	• Adjust the governor shaft position. • Confirm
Setting the Idling Lever Position	360	Approx.9.5	• Adjust using screw ①. • Confirm the control lever angle (32°~42°)

■ Full Load Adjustment (Torque Cam No. 74)

Item	Pump Speed (rpm)	Rack Position (mm)	Remarks
Full Speed Lever Position: Temporary Setting	Approx.2000	(13.7)-0.7	• Adjust using screw ③. (Do not enter governor control range)
Full Load Position Adjustment	1000	13.7	• Adjust using screw ④.
Torque Cam Position Adjustment	1100	(13.7)-0.1	• Adjust using screw ⑤.
	(1150)	(13.7)-0.3	• Confirm
	(1200)	(13.7)-0.3	• "
	(1400)	(13.7)-0.5	• "
	(1600)	(13.7)-0.5	• "
	(1800)	(13.7)-0.7	• "
	—	—	• "
Confirm injection quantity at points A to B.			
Maximum Speed control Adjustment	2005~2015	(13.7)-0.7	• Adjust using screw ③.
	Below 2180	8.5	• Confirm
	—	—	• After adjustment, confirm that the control lever angle is 40°~46°
Confirming Excess Fuel Limit for Engine Starting	435	Approx.9.5	• Set the control lever at point J.
	0	11.5	• Confirm
	0	Above 15	• Move the control lever to the "full-speed" position and then confirm the control rack position.
Confirm the Black Smoke Limit	Fix the control lever at point H. Then, operate the pump at 250 rpm. Confirm that the control rack does not move beyond 13.7 mm. When the control lever is moved to the "full-speed" position again increase the pump speed and confirm that the control rack starts to move from a pump speed of — rpm.		
Rack Limiter Adjustment	0	(15.8)	• Fix the control rack using screw Part No. 157954-3700
	Measure the depth of the control rack cap. Then, adjust screw ⑥ so that it equals the depth of the rack cap and install the rack cap. Confirm injection quantity at point I.		

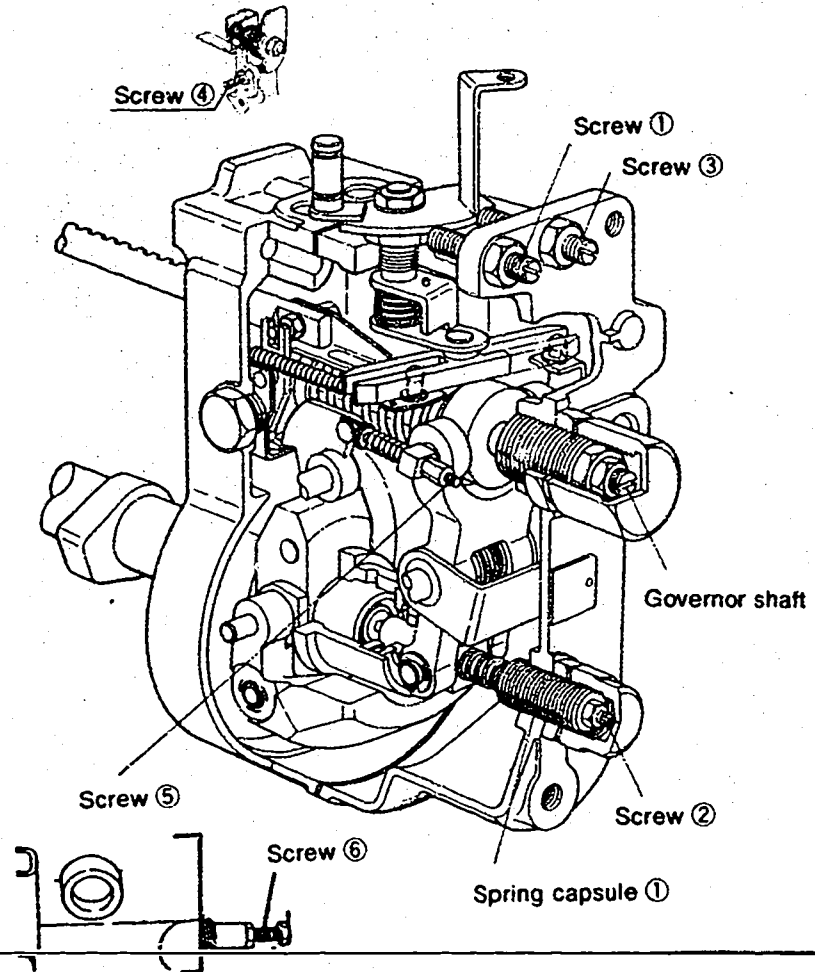

■ Boost Compensator Adjustment

- Maintain the pump speed at 700 rpm and fix the control lever in the full load position.
- In this condition, use calipers to measure the dimension "L" of the pushrod from the end face of the spacer. (Inspection: 23.9 to 24.1 mm)

Item	Pump Speed (rpm)	Rack Position (mm)	Remarks
Setting the Boost Compensator Spring Force	95~135	12.7	• Adjust using screw ⑦.
Boost Compensator Spring Adjustment (Boost compensator stroke: 1.0±0.1 mm)	0	13.7→12.7	• Adjust using screw ⑧.
	95~135	12.7	• Confirm
	300~350	13.7	• Confirm

101641-9132 5/5

BOOST COMPENSATOR ADJUSTMENT

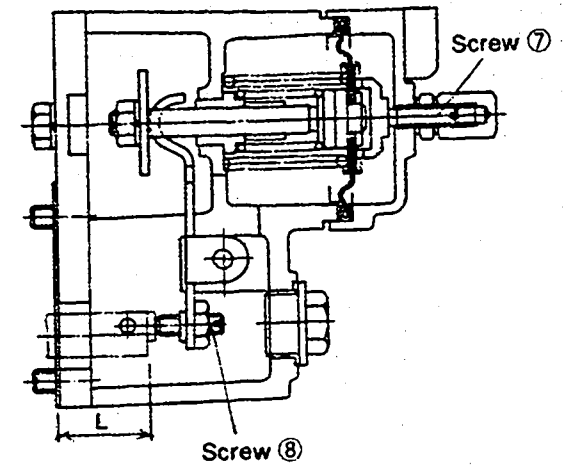
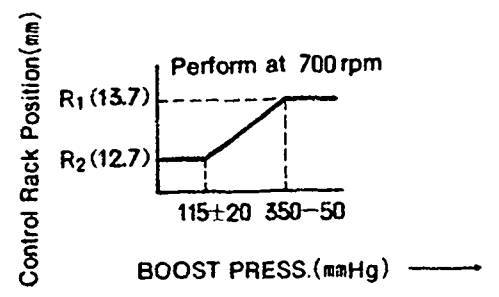

- Timing Setting
- At No. 1 plunger's beginning of injection position.
- B.D.T.C. : 20°

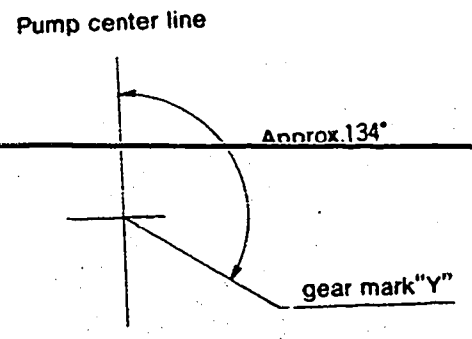

INJ. PUMP CALIBRATION DATA

ENGINE MODEL SD33T

BOSCH No. 9 400 610 006
 DKKC No. 101641-9151
 Date: 20.Nov.1986 [6]
 Company: NISSAN DIESEL
 No. 16700C8702

Injection pump : PES6A Governor : EP/RLD Timing device : EP/SCD
 101064-9050 105931-1520 105622-1120

1. Test Conditions :

Pump rotation : clockwise viewed from drive side

Nozzle & Nozzle Holder Ass'y : 105780-0000 (BOSCH Type No. DN12SD12)
 Nozzle Holder : 105780-2080 (BOSCH Type No. EF8511/9A)

Nozzle opening pressure : 175 Kg/cm² Transfer pump pressure : 1.6 Kg/cm²

Injection pipe : (BOSCH No.)
 Inner Dia. 2 mm X Outer Dia. 6 mm - Length 600 mm

Test Oil : ISO4113 or SAE Standard Test Oil (SAE J967d) Oil Temp. : 40⁺⁵ °C

Overflow valve opening pressure : Kg/cm²

2. Injection Timing :

Pre-stroke : No. 1 Plunger 2.3 ± 0.05mm
 Note : Adjust with control rod position of mm

Injection order : 1 ~ 4 ~ 2 ~ 6 ~ 3 ~ 5 (interval : 60° ± 30')

Plungers are numbered from the Drive side.

Tappet clearance : Bolt adjustment type : More than 0.3mm for all cylinders.
 Shim adjustment type : Manually rotate the camshaft 2~3 times and confirm that it rotates smoothly.

4. Injection Quantity :

Adjust- ing Point	Rod Position (mm)	Pump Speed (r.p.m)	Injection Q'ty (cc/1000 strokes)	Max. var (%)	Part	Remarks
	13.7	1,000	47.2 ~ 49.4	±2	Rack	Basic
H	Approx. 9.9	360	6.4 ~ 8.6	±15	Rack	
A	R ₁ (13.7)	1,000	47.2 ~ 49.4	—	Lever	Basic Boost press. Above 400mmHg
B	R ₁ -0.7	2,000	45.2 ~ 49.2	—	Lever	Boost press. Above 400mmHg
C	R ₂ (12.7)	500	32.6 ~ 36.6	—	Lever	Boost press. 0
I	(15.8)	100	57.0 ~ 67.0	—	Lever	Control rack limit

5. Timing Advance Specification :

Pump Speed (r.p.m)	Below 550	500	1,200	1,900		
Advance Angle (deg.)	Start	Below 0.5	1.7~2.7	Finish 5.5~6.5		

3. GOVERNOR ADJUSTMENT

101641-9151 2/5

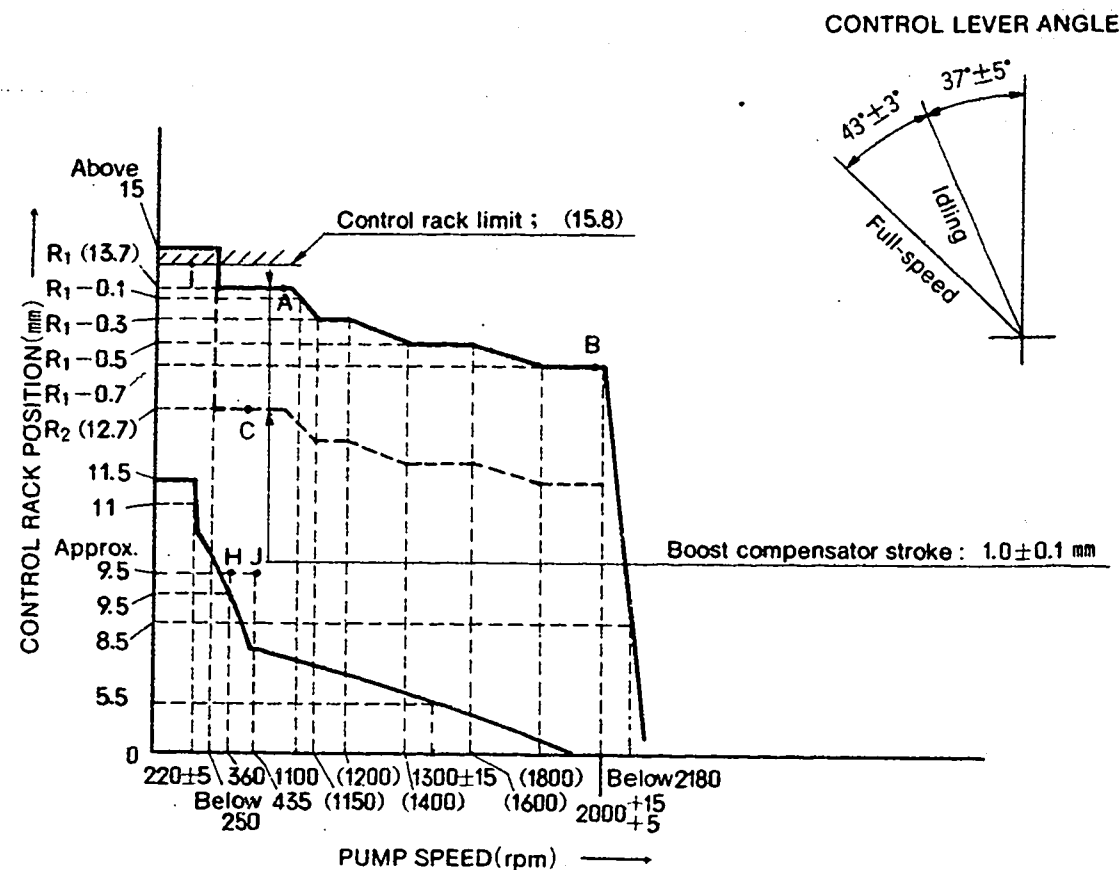

■ Idling Adjustment

Item	Pump Speed (rpm)	Rack Position (mm)	Remarks
Idling Lever Position: Temporary Setting	80~100	11.5	• Adjust using screw ①.
Idling Position Setting	360	9.5	• Adjust using spring capsule ①.
	215~225	11	• Adjust using screw ②.
Governor Spring Contact Adjustment	1285~1315	5.5	• Adjust the governor shaft position.
	—	—	• Confirm
Setting the Idling Lever Position	360	Approx. 9.5	• Adjust using screw ①.
	—	—	• Confirm the control lever angle (32°~42°)

■ Full Load Adjustment (Torque Cam No. 74)

Item	Pump Speed (rpm)	Rack Position (mm)	Remarks
Full Speed Lever Position: Temporary Setting	Approx.2000	(13.7)-0.7	• Adjust using screw ③. (Do not enter governor control range)
Full Load Position Adjustment	1000	13.7	• Adjust using screw ④.
Torque Cam Position Adjustment	1100	(13.7)-0.1	• Adjust using screw ⑤.
	(1150)	(13.7)-0.3	• Confirm
	(1200)	(13.7)-0.3	• "
	(1400)	(13.7)-0.5	• "
	(1600)	(13.7)-0.5	• "
	(1800)	(13.7)-0.7	• "
	—	—	• "
	—	—	• "
Confirm injection quantity at points A to B.			
Maximum Speed control Adjustment	2005~2015	(13.7)-0.7	• Adjust using screw ③.
	Below 2100	8.5	• Confirm • After adjustment, confirm that the control lever angle is 40°~46°
Confirming Excess Fuel Limit for Engine Starting	435	Approx.9.5	• Set the control lever at point J.
	0	11.5	• Confirm
	0	Above 15	• Move the control lever to the "full-speed" position and then confirm the control rack position.
Confirm the Black Smoke Limit	Fix the control lever at point H. Then, operate the pump at 250 rpm. Confirm that the control rack does not move beyond 13.7 mm. When the control lever is moved to the "full-speed" position again increase the pump speed and confirm that the control rack starts to move from a pump speed of — rpm.		
Rack Limiter Adjustment	0	(15.8)	• Fix the control rack using screw Part No. 157954-3700
	Measure the depth of the control rack cap. Then, adjust screw ⑥ so that it equals the depth of the rack cap and install the rack cap. Confirm injection quantity at point I.		

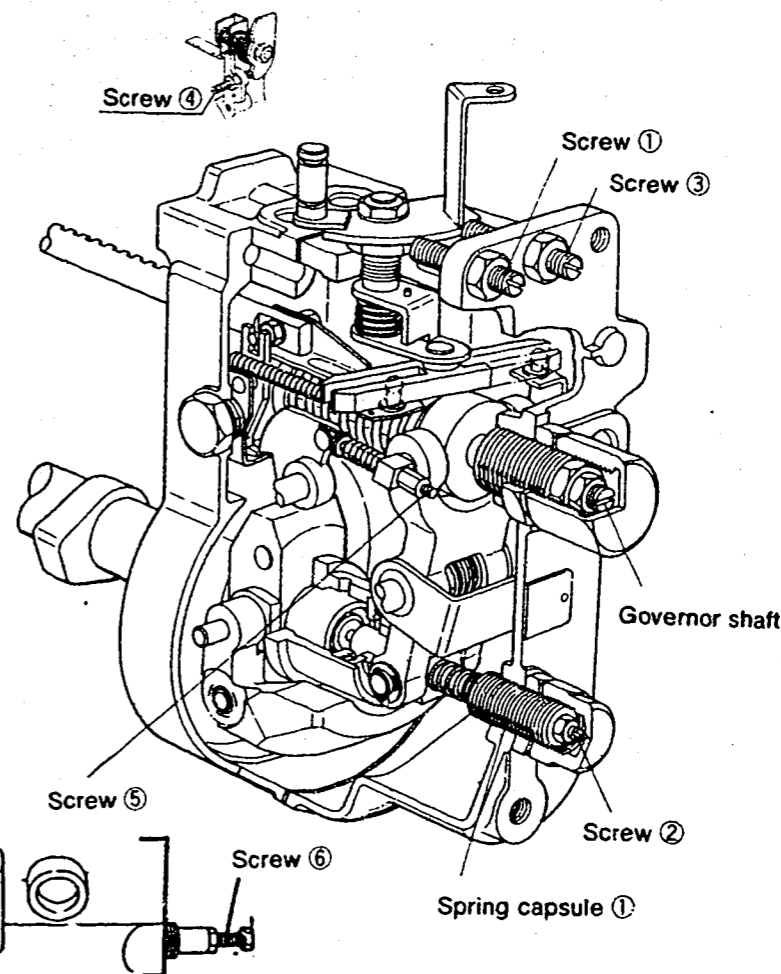

■ Boost Compensator Adjustment

- Maintain the pump speed at 700 rpm and fix the control lever in the full load position.
- In this condition, use calipers to measure the dimension "L" of the pushrod from the end face of the spacer. (Inspection: 23.9 to 24.1 mm)

Item	Pump Speed (rpm)	Rack Position (mm)	Remarks
Setting the Boost Compensator Spring Force	95~135	12.7	• Adjust using screw ⑦.
Boost Compensator Spring Adjustment (Boost compensator stroke: 1.0±0.1 mm)	0	13.7~12.7	• Adjust using screw ⑦.
	95~135	12.7	• Confirm
	300~350	13.7	• Confirm

101641-9151 5/5

BOOST COMPENSATOR ADJUSTMENT

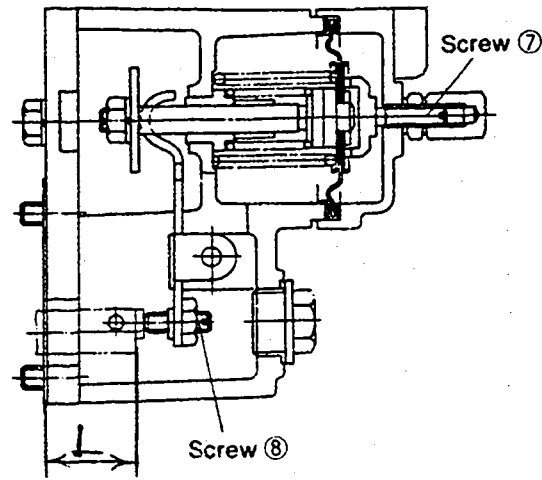
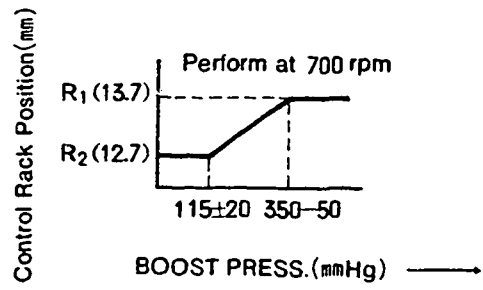

■ Timing Setting

At No. 1 plunger's beginning of injection position.

B.D.T.C. : 20

Pump center line

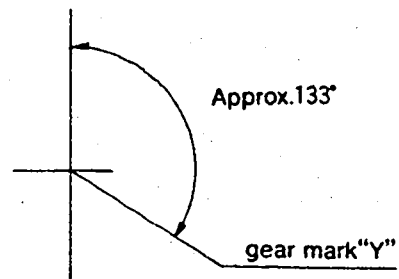

INJ. PUMP CALIBRATION DATA

ENGINE MODEL SD33T

BOSCH No. 9 400 610 026

DKKC No. 101641-9210

Date: 20.Nov.1986 Q

Company: NISSAN DIESEL

No. 16700C8705

Injection pump : PES6A Governor : EP/PLD Timing device : EP/SCD
 101064-9080 105931-3680 105622-1120

1. Test Conditions :

Pump rotation : clockwise viewed from drive side

Nozzle & Nozzle Holder Ass'y : 105780-0000 (BOSCH Type No.DN12SD12)
 Nozzle Holder : 105780-2080 (BOSCH Type No.EF8511/9A)

Nozzle opening pressure : 175 Kg/cm²
 Transfer pump pressure : 1.6 Kg/cm²

Injection pipe : (BOSCH No.)
 Inner Dia. 2 mm X Outer Dia. 6 mm - Length 600 mm

Test Oil : ISO4113 or SAE Standard Test Oil (SAE J967d) Oil Temp. : 40^{±5} °C

Overflow valve opening pressure : Kg/cm²

2. Injection Timing :

Pre-stroke : No. 1 Plunger 2.3 ±0.05mm
 Note : Adjust with control rod position of mm

Injection order : 1 $60^{\pm 30}$, 4, 1 $120^{\pm 30}$, 2, 1 $180^{\pm 30}$, 6, 1 $240^{\pm 30}$, 3, 1 $300^{\pm 30}$, 5 (interval : $^{\circ}\pm 30$)
 Plungers are numbered from the Drive side.

Tappet clearance : Bolt adjustment type : More than 0.3mm for all cylinders.
 : Shim adjustment type : Manually rotate the camshaft 2~3 times and confirm that it rotates smoothly.

4. Injection Quantity :

Adjusting Point	Rod Position (mm)	Pump Speed (r.p.m)	Injection Q'ty (cc/1000 strokes)	Max. var bet. cyl (%)	Fixed	Remarks
	13.7	1,000	47.2 ~ 49.4	±2	Rack	Basic
H	Approx. 9.5	360	6.4 ~ 8.6	±15	Rack	
A	R ₁ (13.7)	1,000	47.2 ~ 49.4	—	Lever	Basic Boost press. Above 400mmHg
B	R ₁ -0.7	2,000	45.2 ~ 49.2	—	Lever	Boost press. Above 400mmHg
C	R ₂ (12.7)	500	32.6 ~ 36.6	—	Lever	
I	Above 18	100	(42.2)	—	Lever	

5. Timing Advance Specification :

Pump Speed (r.p.m)	Below 550	500	1,200	1,900
Advance Angle (deg.)	Start	Below 0.5	1.7~2.7	Finish 5.5~6.5

3. GOVERNOR ADJUSTMENT

101641-9210 2/5

CONTROL LEVER ANGLE

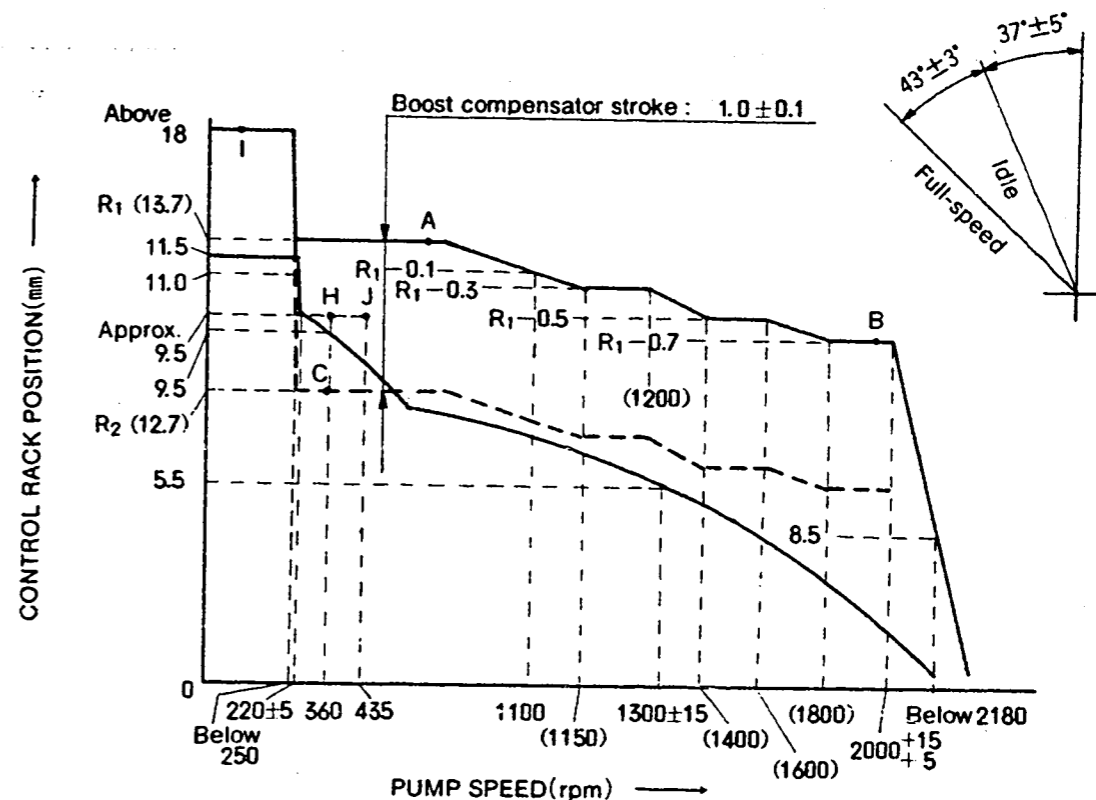

■ Idling Adjustment

Item	Pump Speed (rpm)	Rack Position (mm)	Remarks
Idling Lever Position: Temporary Setting	80~100	11.5	• Adjust using screw ①.
Idling Position Setting	360 215~225	9.5 11	• Adjust using spring capsule ①. • Adjust using screw ②.
Governor Spring Contact Adjustment	1285~1315	5.5	• Adjust the governor shaft position. • Confirm
Setting the Idling Lever Position	360	Approx. 9.5	• Adjust using screw ①. • Confirm the control lever angle (32°~42°)

■ Full Load Adjustment (Torque Cam No. 74)

Item	Pump Speed (rpm)	Rack Position (mm)	Remarks
Full Speed Lever Position: Temporary Setting	Approx.2000	(13.7) - 0.7	• Adjust using screw ③. (Do not enter governor control range)
Full Load Position Adjustment	1000	13.7	• Adjust using screw ④.
Torque Cam Position Adjustment	1100	(13.7) - 0.1	• Adjust using screw ⑤.
	(1150)	(13.7) - 0.3	• Confirm
	(1200)	(13.7) - 0.3	• "
	(1400)	(13.7) - 0.5	• "
	(1600)	(13.7) - 0.5	• "
	(1800)	(13.7) - 0.7	• "
	—	—	• "
	—	—	• "
Confirm injection quantity at points A to B.			
Maximum Speed control Adjustment	2005~2015	(13.7) - 0.7	• Adjust using screw ③.
	Below 2180	8.5	• Confirm • After adjustment, confirm that the control lever angle is 40°~46°
Confirming Excess Fuel Limit for Engine Starting	435	Approx.9.5	• Set the control lever at point J .
	0	11.5	• Confirm
	0	Above 18	• Move the control lever to the "full-speed" position and then confirm the control rack position.
Confirm the Black Smoke Limit	Fix the control lever at point H. Then, operate the pump at 250 rpm. Confirm that the control rack does not move beyond 13.7 mm. When the control lever is moved to the "full-speed" position again increase the pump speed and confirm that the control rack starts to move from a pump speed of — rpm.		
Rack Limiter Adjustment	—	—	• Fix the control rack using screw Part No. 157954-3700
	Measure the depth of the control rack cap. Then, adjust screw ⑥ so that it equals the depth of the rack cap and install the rack cap. Confirm injection quantity at point I .		

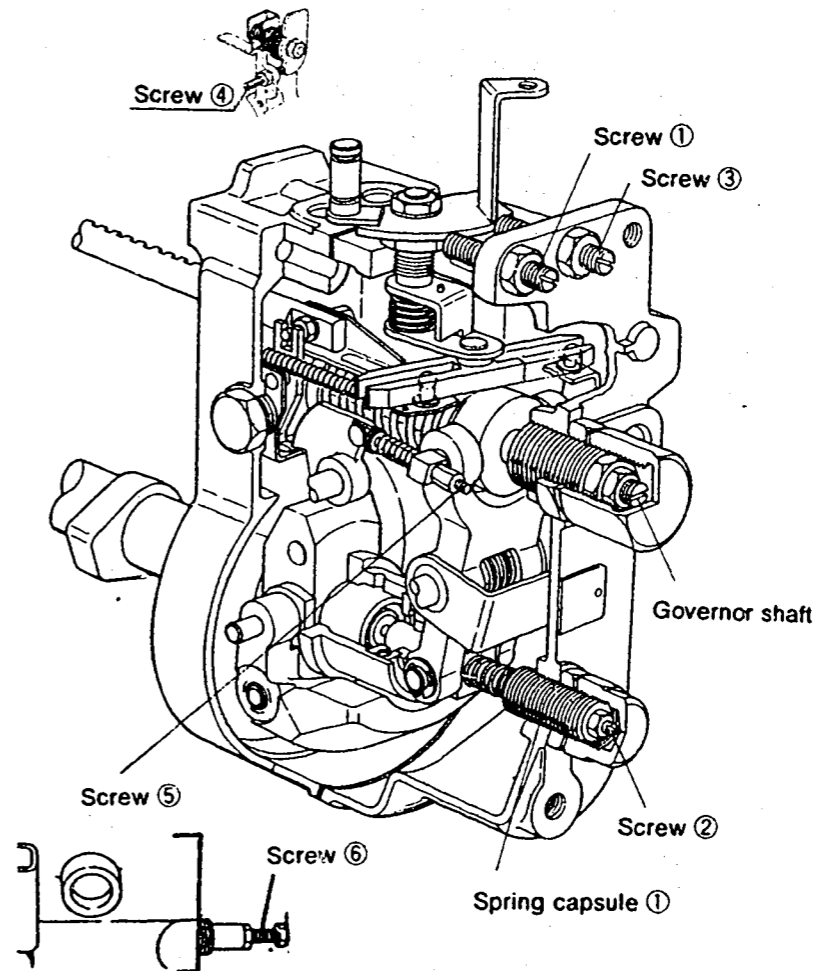

■ Boost Compensator Adjustment

- Maintain the pump speed at 700 rpm and fix the control lever in the full load position.
- In this condition, use calipers to measure the dimension "L" of the pushrod from the end face of the spacer. (Inspection: 23.9 to 24.1 mm)

Item	Pump Speed (rpm)	Rack Position (mm)	Remarks
Setting the Boost Compensator Spring Force	95~135	12.7	• Adjust using screw ⑦.
Boost Compensator Spring Adjustment (Boost compensator stroke: 1.0±0.1 mm)	0	13.7→12.7	• Adjust using screw ⑦.
	95~135	12.7	• Confirm
	300~350	13.7	• Confirm

101641-9210 5/5

BOOST COMPENSATOR ADJUSTMENT

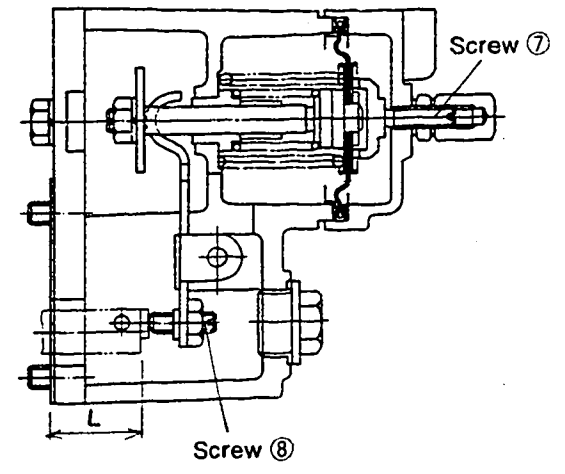
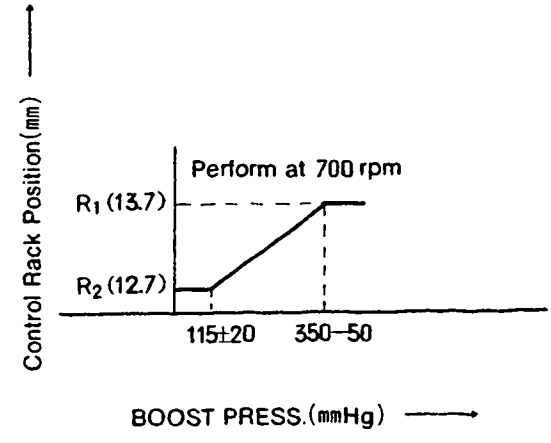

■ Timing Setting

At No. 1 plunger's beginning of injection position.
B.D.T.C. : 20°

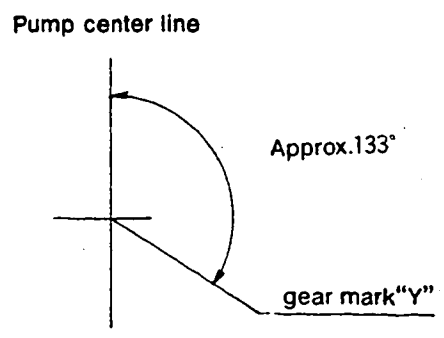

INJ. PUMP CALIBRATION DATA

ENGINE MODEL DA120

BOSCH No.9 400 610 022
 DKKC No. 101685-0600
 Date: 20.Nov.1986 2
 Company: ISUZU
 No. 1-15600-030-2

Injection pump : PE6A Governor : EP/RBD Timing device :
 101068-3610 105540-6290

1. Test Conditions :

Pump rotation : clockwiseviewed from drive side

Nozzle & Nozzle Holder Ass'y : 105780-0000 Nozzle Holder : 105780-2080
 (BOSCH Type No.DN12SD12) (BOSCH Type No.EF8511/9A)

Nozzle opening pressure : 175 Kg/cm² Transfer pump pressure : 1.6 Kg/cm²

Injection pipe :
 Inner Dia. 2 mm X Outer Dia. 6 mm - Length 600 mm

Test Oil : ISO4113 or SAE Standard Test Oil (SAE J967d) Oil Temp. : 40⁺5 °C

Overflow valve opening pressure : Kg/cm²

2. Injection Timing :

Pre-stroke : No. 1 Plunger mm

Note : Adjust with control rod position of mm

Injection order : 1 ~ 4 ~ 2 ~ 6 ~ 3 ~ 5 (interval : 60 °±30')

Plungers are numbered from the Drive side.

Tappet clearance : Bolt adjustment type ; More than 0.3mm for all cylinders.
 ; Shim adjustment type ; Manually rotate the camshaft 2~3 times and confirm that it rotates smoothly.

4. Injection Quantity :

Adjust- ing Point:	Rod Position (mm)	Pump Speed (r.p.m)	Injection Q'ty (cc/1000 strokes)	Max. var bet. cyl (%)	Fixed	Remarks
	13.5	750	61.6 ~ 64.4	±2	Rack	Basic
	13.0	1,200	61.3 ~ 65.3	±3	Rack	
	11.5	750	37.0 ~ 40.4	±4	Rack	
	Approx. 10	225	13.3 ~ 16.7	±13	Rack	

5. Timing Advance Specification :

Pump Speed (r.p.m)	Advance Angle (deg.)				

3. GOVERNOR ADJUSTMET

101685-0600 2/3

(1)Pneumatic Governor

(2)Mechanical Governor

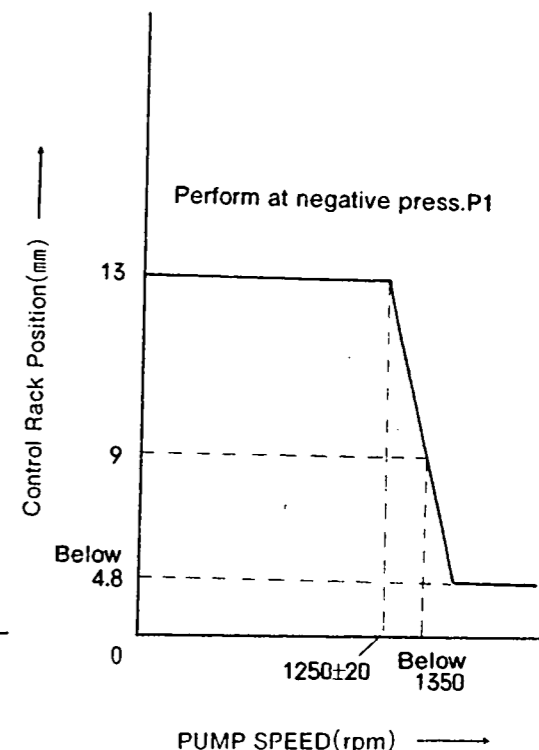
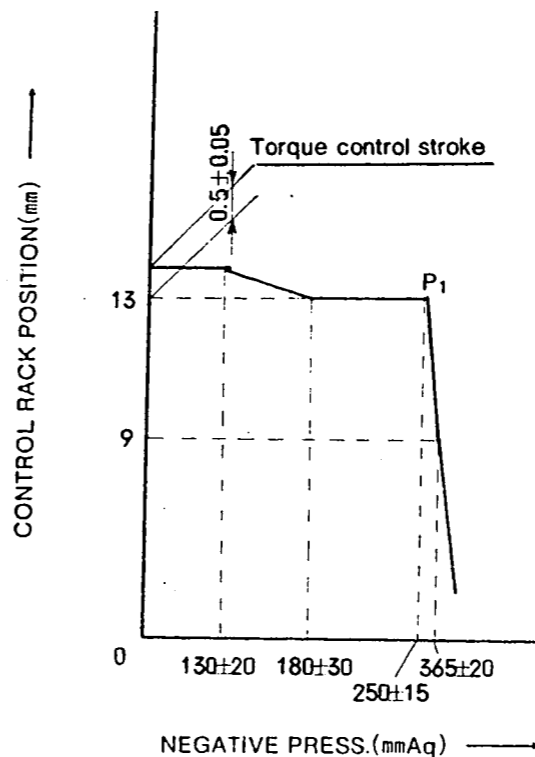

■ Air Tightness Test

1. Increase the pressure of the pneumatic governor's negative pressure chamber to 200 mmAq at a pump speed of 500 rpm and a control rack position of approx.13.5 mm.
2. Then, confirm that it takes 10 seconds or more for the negative pressure to fall from 500 mmAq to 480 mmAq.

■ Adjustment

1. Pneumatic Governor (Pump Speed : 500 rpm)

Item	Negative Press. (mmAq)	Rack Position (mm)	Remarks
Smoke Set Screw Adjust- ment	0	Approx.13.5	• Adjust using spring capsule ①.
Torque Control Adjustment			
①Start of torque control spring movement	110~150	Approx.13.5	• Adjust thickness of shim ①.
②End of torque control spring movement	150~210	13	• Adjust thickness of shim ②.
③Confirm	—	—	
④Confirm torque control stroke	—	—	• Inspection : 0.5±0.05 mm

101685-0600 3/3

Item	Negative Press. (mmAq)	Rack Position (mm)	Remarks
High-speed control Adjustment	235~265	13	• Adjust thickness of shim ③.
	345~385	9	• Confirm
Idling Adjustment	—	—	• Adjust using spring capsule ②. • Confirm

2. Mechanical Governor (Negative pressure: 235~265 mmAq)

Item	Pump Speed (rpm)	Rack Position (mm)	Remarks
Maximum-Speed Control Adjustment	1230~1270	13	• Adjust using screw ①.
	Below 1350	Below 4.8	• Confirm
	—	—	• Confirm (Check the fuel injection quantity: below 3 cc/1000st)

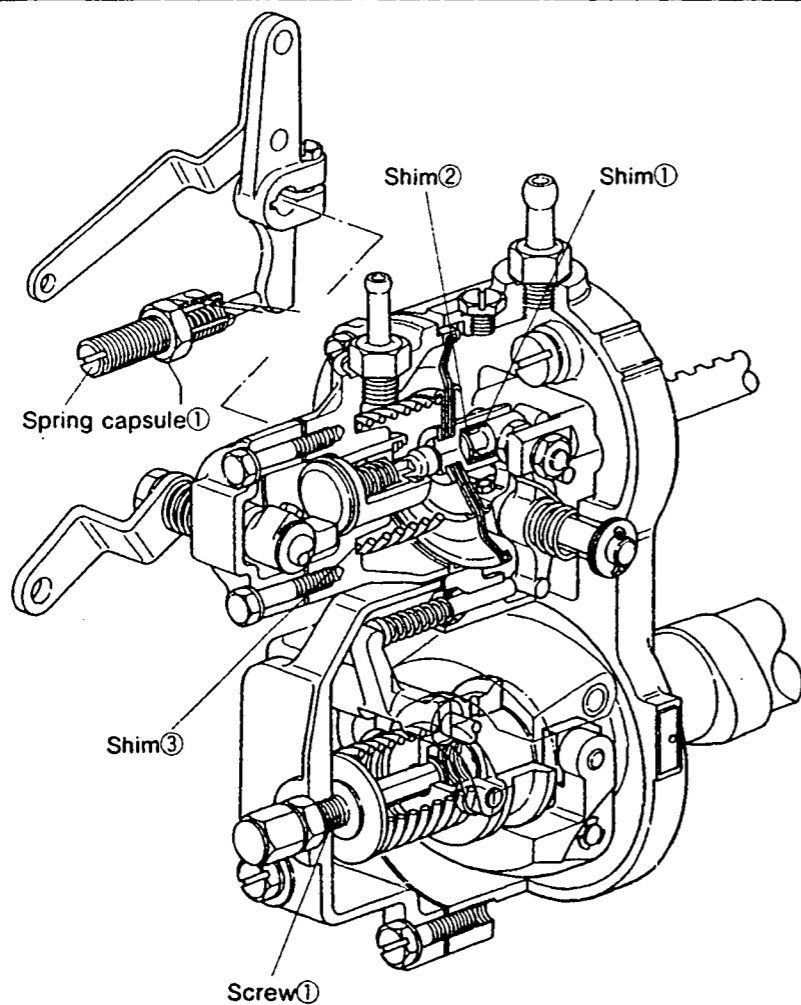

INJ. PUMP CALIBRATION DATA

ENGINE MODEL 8DC20

BOSCH No.9 400 610 025

DKKC No. 101891-6620

Date: 20.Nov.1986 3

Company: MITSUBISHI

No. 31261-50040

Injection pump : PE8A
101089-0470

Governor : EP/HFD
105490-3960

Timing device : EP/SA
105612-1260

1. Test Conditions :

Pump rotation : clockwiseviewed from drive side

Nozzle & Nozzle Holder Ass'y : 105780-0000 (BOSCH Type No.DN12SD12T)
Nozzle Holder : 105780-2080 (BOSCH Type No.EF8511/9A)
Nozzle opening pressure : 175 Kg/cm²
Transfer pump pressure : 1.6 Kg/cm²

Injection pipe : Inner Dia. 2 mm X Outer Dia. 6 mm - Length 600 mm

Test Oil : ISO4113 or SAE Standard Test Oil (SAE J967d) Oil Temp. : 40⁺⁵ °C

Overflow valve opening pressure : - Kg/cm²

2. Injection Timing :

Pre-stroke : No. 1 Plunger 2.2 ±0.05mm

Note : Adjust with control rod position of - mm

Injection order : 1 ~ 2 ~ 7 ~ 3 ~ 4 ~ 5 ~ 6 ~ 8 (interval : 45° ±30')

Plungers are numbered from the Governor side.

Tappet clearance : Bolt adjustment type : More than 0.3mm for all cylinders.

: Shim adjustment type : Manually rotate the camshaft 2~3 times and confirm that it rotates smoothly.

4. Injection Quantity :

Adjusting Point	Rod Position (mm)	Pump Speed (r.p.m)	Injection Q'ty (cc/1000 strokes)	Max. var bet. cyl (cc)	Fixed	Remarks
A	12.5	800	111.5 ~ 118.5	±3	Rack	Basic
H	Approx. 6.3	200	9.8 ~ 15.0	±15	Rack	
A	12.5	800	111.5 ~ 118.5	-	Lever	Basic
C	-	1,200	qB=qA-1.5±3.5	-	Lever	
B	10.5	800	81.9 ~ 90.9	±5	Lever	

5. Timing Advance Specification :

Pump Speed (r.p.m)	250+120	500	800	1,200	-		
Advance Angle (deg.)	Start	0.8~2.0	3.6~4.8	7.3~8.5	Finish Approx. 10.0		

3. GOVERNOR ADJUSTMENT

101891-6620 2/4

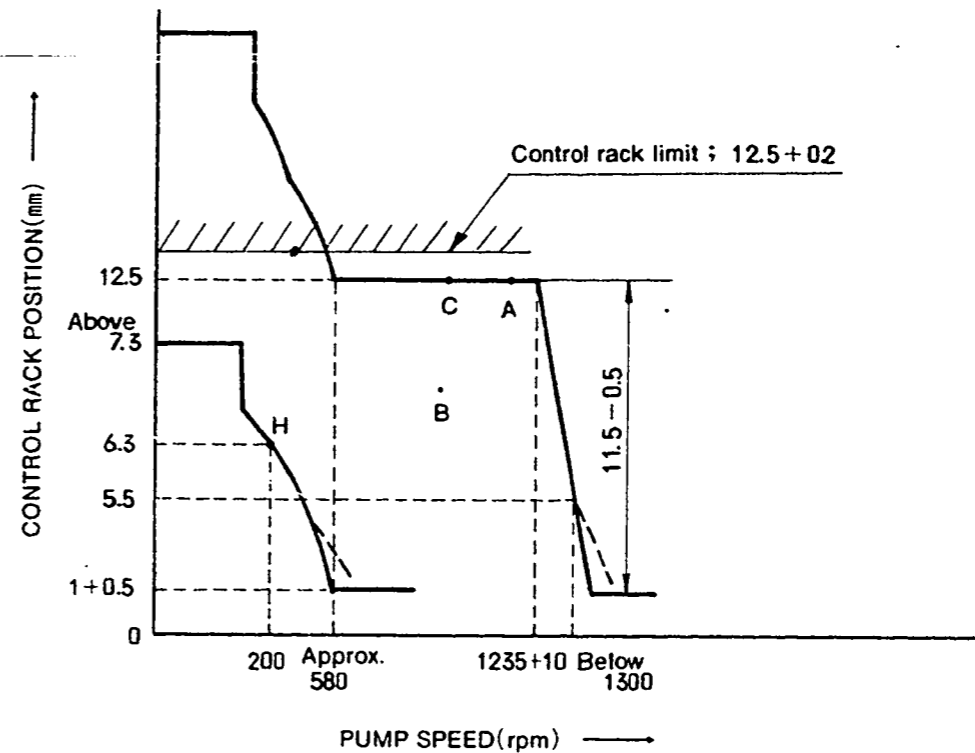

• LOAD CONTROL LEVER ANGLE

• SPEED CONTROL LEVER ANGLE

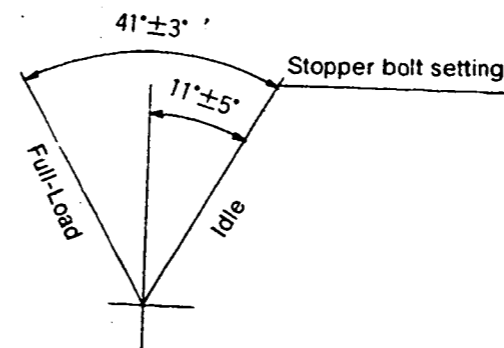

■ Note :

Before adjustment, remove the damper spring, the cover and the idling spring capsule.

■ Adjustment

Item	Pump Speed (rpm)	Rack Position (mm)	Remarks
Flyweight Lift And Full-Load Position	700~800	12.5	• Speed control lever: temporary setting.
	Above 1300	0.5~1.0	• Adjust using screw ①.
Decrease pump speed to 1235 rpm and adjust the high speed lift value (11.5~0.5) using screw ②.			
Idling Adjustment	Below 580	1.0~1.5	• Adjust using screw ③
	200	6.3	• Adjust using spring capsule ①
	Below 580	1.0~1.5	• Confirm
	0	Above 7.3	• Confirm
• Confirm the control lever angle is 6°~16°.			
Damper Spring Setting	Maintain the pump speed at 200 rpm and set the control rod at the 6.3mm position using the control lever. Then, gradually increase the pump speed until the rod position is 4.5~0.2mm. Tighten the damper spring capsule and fix it in the position where it begins to move the rod from the 4.5~0.1mm position.		
Maximum Speed Starting Point and Speed Droop Check	Fix the load control lever in the full-load position and fix the speed control lever in the full-speed position.		
	1235~1245 Below 1300 ---	12.5 5.5 ---	• Adjust using screw ④ • Confirm • Confirm the control lever angle (Speed lever angle: ---, 38°~44°; Load lever angle).
Smoke Limiter Setting	Fix the load control lever in the full-load position.		
	0	12.5~12.7	• Adjust using smoke limiter.

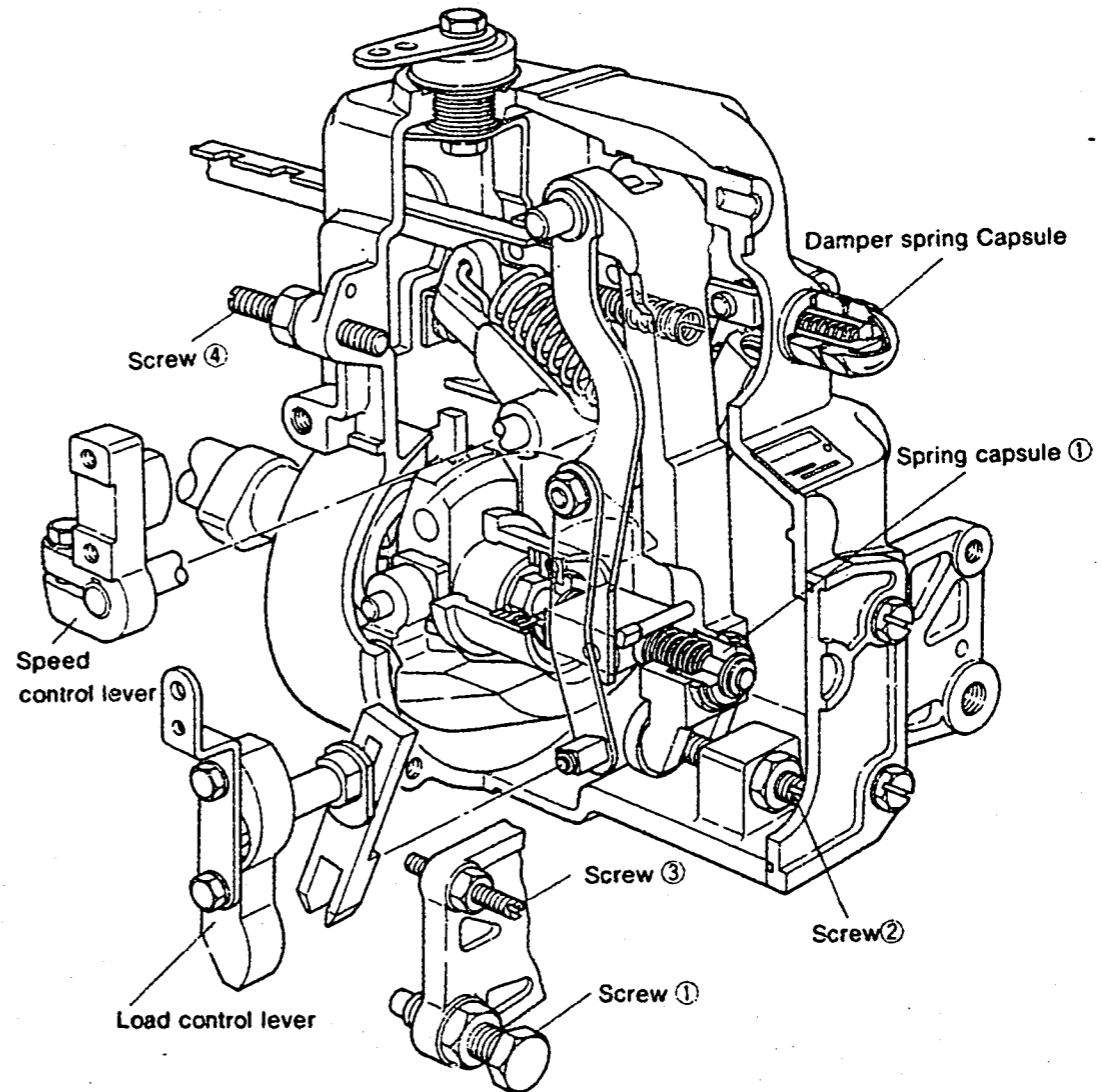

H - 5

INJ. PUMP CALIBRATION DATA

ENGINE MODEL Z400

BOSCH No. 9 410 617 000

DKKC No. 104205-2010

Date 20.Nov.1986 2

Company: KUBOTA

No. 15852 5101

INJ. Pump Ass'y No. 104205-2010 (NP-PFR2MD50/1NP2)

1. Test Conditions :

Nozzle & Nozzle Holder Ass'y No. : 105780-8140

Nozzle No. : 105780-0000 (Bosch Type No. DN12SD12T)

Nozzle Holder No. : 105780-2080 (Bosch Type No. EF8511/9A)

Nozzle Opening Press : 120 Kg/cm² Transfer Pump Press : 0.5 Kg/cm²

Injection Pipe No. : 157805-3320

Inner Dia. 2 mm X Outer Dia. 6 mm - Length 600 mm

Test Oil : ISO4113 or SAE Standard Test Oil (SAE J967d) Oil Temp. : 35⁺¹⁰ °C

Cam Profile : PFK-T-00 (Tangential Cam , Cam Lift 7 mm , Base Circle φ28)

2. Injection Timing :

PRE-STROKE : 1.9 ±0.05 mm

L₁ (Port Closing Dimension) : 64.1 ±0.05 mm

L₂ (Mounting Dimension) : 66.0 ±0.05 mm

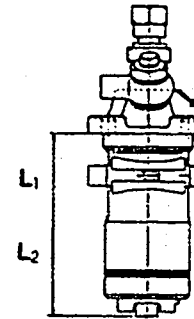

3. Injection Quantity :

Rod Position (mm)	Pump Speed (r.p.m)	Injection Q'ty (cc/1000 strokes)	Max. var bet. cyl (%)	Fixed	Remarks
a(4.8)	1,800	11.7 ~ 12.3	-	Rod	Basic

() = Reference value

4. Control Rod Sliding Resistance :

Pump Speed (r.p.m)	Sliding Resistance (g)
0	Below 50
200	Below 30
1,000	Below 20



DIESEL KIKI CO., LTD.
Service Department

3-6-7 SHIBUYA, SHIBUYA-KU, TOKYO 150, JAPAN
Tel: (03) 400-1551 Fax: (03) 499-4115

H - 6

INJ. PUMP CALIBRATION DATA

ENGINE MODEL D600

BOSCH No.9 410 617 001

DKKC No. 104205-3010

Date : 20.Nov.1986 2

Company : KUBOTA

No. 15862 5101

INJ.Pump Ass'y No. 104205-3010 (NP-PFR3MD50/1NP2)

1. Test Conditions :

Nozzle & Nozzle Holder Ass'y No. : 105780-8140

Nozzle No. : 105780-0000(BOSCH TYPE No. DN12SD12T)

Nozzle Holder No. : 105780-2080(BOSCH TYPE No. EF8511/9A)

Nozzle Opening Press : 120 Kg/cm² Transfer Pump Press : 0.5 Kg/cm²

Injection Pipe No. : 157805-3320

Inner Dia. 2 mm X Outer Dia. 6 mm - Length 600 mm

Test Oil : ISO4113 or SAE Standard Test Oil (SAE J967d) Oil Temp. : 35⁺¹⁰ °C

Cam Profile : PFK-T-00 (Tangential Cam , Cam Lift 7 mm , Base Circle φ28)

2. Injection Timing :

PRE-STROKE : 1.9 ±0.05 mm

L₁ (Port Closing Dimension) : 64.1 ±0.05 mm

L₂ (Mounting Dimension) : 66.0 ±0.05 mm

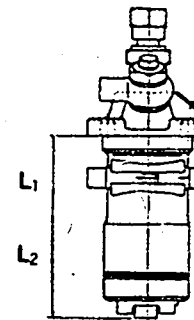

3. Injection Quantity :

Rod Position (mm)	Pump Speed (r.p.m)	Injection Q'ty (cc/1000 strokes)	Max. var bet. cyl (%)	Fixed	Remarks
4.8	1,800	11.7 ~ 12.3	-	Rod	Basic

() = Reference value

4. Control Rod Sliding Resistance :

Pump Speed (r.p.m)	Sliding Resistance (g)
0	Below 50
200	Below 30
1,000	Below 20



DIESEL KIKI CO. LTD.
Service Department

3-6-7 SHIBUYA, SHIBUYA-KU, TOKYO 150, JAPAN
Tel. (03) 400-1551 · Fax: (03) 499-4115

H - 7**INJ. PUMP CALIBRATION DATA**

ENGINE MODEL Z500(A11)

INJ. Pump Ass'y No. 104293-2020 (NP-PFR2KD50/2NP3)

BOSCH No. 9 410 617 002

DKKC No. 104293-2020

Date : 20. Nov. 1986 4

Company : KUBOTA

No. 15261 5101

1. Test Conditions :

Nozzle & Nozzle Holder Ass'y No. : 105780-8140

Nozzle No. : 105780-0000 (BOSCH TYPE No. DN12SD12T)

Nozzle Holder No. : 105780-2080 (BOSCH TYPE No. EF8511/9A)

Nozzle Opening Press. : 120 Kg/cm² Transfer Pump Press. : 0.5 Kg/cm²

Injection Pipe No. : 157805-3320

Inner Dia. 2 mm × Outer Dia. 6 mm - Length 600 mm

Test Oil : ISO4113 or SAE Standard Test Oil (SAE J967d) Oil Temp. : 35⁺¹⁰ °C

Cam Profile : PFK-T-00 (Tangential Cam , Cam Lift 7 mm , Base Circle φ28)

2. Injection Timing :

PRE-STROKE : 2.1 ± 0.05 mm

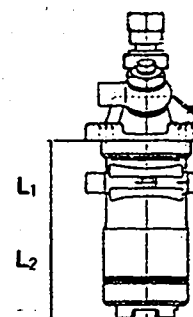
L₁ (Port Closing Dimension) : 73.9 ± 0.05 mmL₂ (Mounting Dimension) : 76.0 ± 0.05 mm**3. Injection Quantity :**

Rod Position (mm)	Pump Speed (r.p.m)	Injection Q'ty (cc/1000 strokes)	Max. var bet. cyl (%)	Fixed	Remarks
a	800	12.5 ~ 13.1	-	Rod	Basic
a+2	800	19.9 ~ 24.1	±2	Rod	
a-1	800	7.7 ~ 10.7	±2	Rod	
a-1	200	3.9 ~ 8.9	±5	Rod	

() = Reference value

4. Control Rod Sliding Resistance :

Pump Speed (r.p.m)	Sliding Resistance (g)
0	Below 50
200	Below 30
1,000	Below 20

H - 8

INJ. PUMP CALIBRATION DATA

ENGINE MODEL Z600C

INJ. Pump Assy No. 104293-2030 (NP-PFR2KD50/2NP8)

BOSCH No. 9 410 617 006
DKKC No. 104293-2030
Date : 20. Nov. 1986 2
Company : KUBOTA
No. 15951 5101

1. Test Conditions :

Nozzle & Nozzle Holder Assy No. : 105780-8140

Nozzle No. : 105780-0000 (BOSCH TYPE No. DN12SD12T)

Nozzle Holder No. : 105780-2080 (BOSCH TYPE No. EF8511/9A)

Nozzle Opening Press. : 120 Kg/cm² Transfer Pump Press. : 0.5 Kg/cm²

Injection Pipe No. : 157805-3320
 Inner Dia. 2 mm X Outer Dia. 6 mm - Length 600 mm

Test Oil : ISO4113 or SAE Standard Test Oil (SAE J967d) Oil Temp. : 35⁺¹⁰ °C

Cam Profile : PFK-T-00 (Tangential Cam . Cam Lift 7 mm . Base Circle φ28)

2. Injection Timing :

PRE-STROKE : 2.1 ± 0.05 mm

L₁ (Port Closing Dimension) : 73.9 ± 0.05 mm

L₂ (Mounting Dimension) : 76.0 ± 0.05 mm

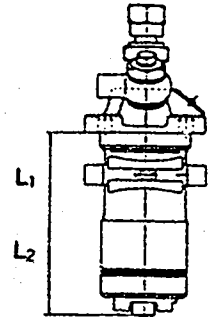

3. Injection Quantity :

Rod Position (mm)	Pump Speed (r.p.m)	Injection Q'ty (cc/1000 strokes)	Max. var bet. cyl (%)	Fixed	Remarks
a	1,300	13.7 ~ 14.3	-	Rod	Basic
a+2	1,300	19.3 ~ 24.3	±2	Rod	
a-1	1,300	8.8 ~ 12.8	±2	Rod	
a-1	200	1.7 ~ 8.7	±5	Rod	

() = Reference value

4. Control Rod Sliding Resistance :

Pump Speed (r.p.m)	Sliding Resistance (g)
0	Below 50
200	Below 30
1,000	Below 20

H - 9**INJ. PUMP CALIBRATION DATA**

ENGINE MODEL D650,D750,D850

INJ.Pump Ass'y No. 104293-3000 (NP-PFR3KD50/2NP4)

BOSCH No.9 410 617 003

DKKC No. 104293-3000

Date : 20.Nov.1986

Company : KUBOTA

No. 15381 5101

1. Test Conditions :

Nozzle & Nozzle Holder Ass'y No. : 105780-8140

Nozzle No. : 105780-0000(BOSCH TYPE No. DN12SD12T)

Nozzle Holder No. : 105780-2080(BOSCH TYPE No. EF8511/9A)

Nozzle Opening Press. : 120 Kg/cm² Transfer Pump Press. : 0.5 Kg/cm²

Injection Pipe No. : 157805-3320

Inner Dia. 2 mm X Outer Dia. 6 mm - Length 600 mm

Test Oil : ISO4113 or SAE Standard Test Oil (SAE J967d) Oil Temp. : 35⁺¹⁰ °C

Cam Profile : PFK-T-00 (Tangential Cam , Cam Lift 7 mm , Base Circle φ28)

2. Injection Timing :

PRE-STROKE : 2.1 mm

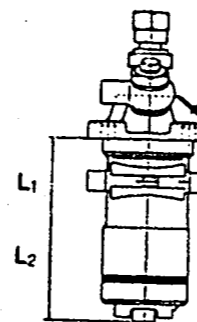
L₁ (Port Closing Dimension) : 73.9±0.05 mmL₂ (Mounting Dimension) : 76.0±0.05 mm**3. Injection Quantity :**

Rod Position (mm)	Pump Speed (r.p.m)	Injection Q'ty (cc/1000 strokes)	Max. var bet. cyl (%)	Fixed	Remarks
a	1,400	15.2 ~ 15.8	—	Rod	Basic
a+2	1,400	22.3 ~ 25.5	—	Rod	
a-1	1,400	10.0 ~ 12.8	—	Rod	
a-1	400	4.3 ~ 8.1	—	Rod	

() = Reference value

4. Control Rod Sliding Resistance :

Pump Speed (r.p.m)	Sliding Resistance (g)
0	Below 50
200	Below 30
1,000	Below 20

DIESEL KIKI
DIESEL KIKI CO. LTD.
 Service Department

 3-6-7 SHIBUYA, SHIBUYA-KU, TOKYO 150, JAPAN
 Tel (03) 400-1551 · Fax (03) 499-4115

H - 10

INJ. PUMP CALIBRATION DATA

ENGINE MODEL D950

INJ. Pump Ass'y No. 104293-3010 (NP-PFR3KD50/2NP6)

BOSCH No. 9 410 617 004

DKKC No. 104293-3010

Date: 20. Nov. 1986 2

Company: KUBOTA

No.

1. Test Conditions :

Nozzle & Nozzle Holder Ass'y No. : 105780-8140

Nozzle No. : 105780-0000 (BOSCH TYPE No. DN12SD12T)

Nozzle Holder No. : 105780-2080 (BOSCH TYPE No. EF8511/9A)

Nozzle Opening Press. : 120 Kg/cm² Transfer Pump Press. : 0.5 Kg/cm²

Injection Pipe No. : 157805-3320
 Inner Dia. 2 mm X Outer Dia. 6 mm - Length 600 mm

Test Oil : ISO4113 or SAE Standard Test Oil (SAE J967d) Oil Temp. : 35⁺¹⁰ °C

Cam Profile : PFK-T-00 (Tangential Cam , Cam Lift 7 mm , Base Circle φ28)

2. Injection Timing :

PRE-STROKE : 2.1 ± 0.05 mm

L₁ (Port Closing Dimension) : 73.9 ± 0.05 mm

L₂ (Mounting Dimension) : 76.0 ± 0.05 mm

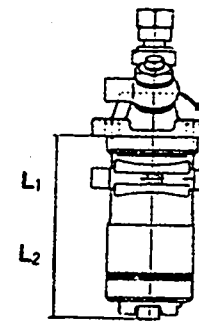

3. Injection Quantity :

Rod Position (mm)	Pump Speed (r.p.m)	Injection Q'ty (cc/1000 strokes)	Max. var bet. cyl (%)	Fixed	Remarks
a	1,400	15.2 ~ 15.8	—	Rod	Basic
a+2	1,400	22.3 ~ 25.5	—	Rod	
a-1	1,400	10.0 ~ 12.8	—	Rod	
a-1	400	4.3 ~ 8.1	—	Rod	

() = Reference value

4. Control Rod Sliding Resistance :

Pump Speed (r.p.m)	Sliding Resistance (g)
0	Below 50
200	Below 30
1,000	Below 20

H - 11

INJ. PUMP CALIBRATION DATA

ENGINE MODEL V1100BBS,V1200BBS

INJ.Pump Ass'y No. 104293-4000 (NP-PFR4KD50/2NP1)

BOSCH No.9 410 617 005

DKKC No. 104293-4000

Date : 20.Nov.1986 2

Company : KUBOTA

No. 15442 51011

1. Test Conditions :

Nozzle & Nozzle Holder Ass'y No. : 105780-8140

Nozzle No. : 105780-0000(BOSCH TYPE No. DN12SD12T)

Nozzle Holder No. : 105780-2080(BOSCH TYPE No. EF8511/9A)

Nozzle Opening Press. : 120 Kg/cm² Transfer Pump Press. : 0.5 Kg/cm²

Injection Pipe No. : 157805-3320

Inner Dia. 2 mm X Outer Dia. 6 mm - Length 600 mm

Test Oil : ISO4113 or SAE Standard Test Oil (SAE J967d) Oil Temp. : 35⁺¹⁰ °C

Cam Profile : PFK-T-00 (Tangential Cam , Cam Lift 7 mm , Base Circle φ28)

2. Injection Timing :

PRE-STROKE : 2.1±0.05 mm

L₁ (Port Closing Dimension) : 73.9±0.05 mm

L₂ (Mounting Dimension) : 76.0±0.05 mm

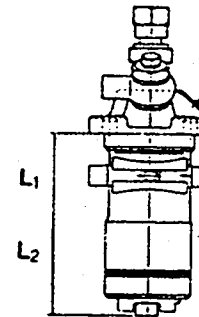

3. Injection Quantity :

Rod Position (mm)	Pump Speed (r.p.m)	Injection Q'ty (cc/1000 strokes)	Max. var bet. cyl (%)	Fixed	Remarks
a	1,400	15.2 ~ 15.8	—	Rod	Basic
a+2	1,400	22.3 ~ 25.5	—	Rod	
a-1	1,400	10.0 ~ 12.8	—	Rod	
a-1	400	4.3 ~ 8.1	—	Rod	

() = Reference value

4. Control Rod Sliding Resistance :

Pump Speed (r.p.m)	Sliding Resistance (g)
0	Below 50
200	Below 30
1,000	Below 20

 **DIESEL KIKI**

DIESEL KIKI CO., LTD.
Service Department

3-6-7 SHIBUYA, SHIBUYA-KU, TOKYO 150, JAPAN
Tel (03) 400-1551 · Fax (03) 499-4115

H - 12

INJ. PUMP CALIBRATION DATA

ENGINE MODEL S148

BOSCH No.9 400 610 024
 DKKC No. 104302-6470
 Date : 20.Nov.1986 [2]
 Company : TOYO-SHA

3. GOVERNOR ADJUSTMENT

104302-6470 2/3

CONTROL LEVER ANGLE

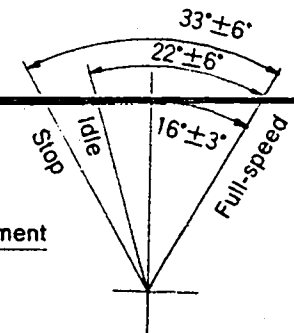

Injection pump : PES2K Governor : Timing device :
 104300-0560

1. Test Conditions :

Pump rotation : clockwise viewed from drive side

Nozzle & Nozzle Holder Ass'y : 105780-0000 Nozzle Holder : 105780-2080
 (BOSCH Type No.DN12SD12) (BOSCH Type No.EF8511/9A)

Nozzle opening pressure : 175 Kg/cm² Transfer pump pressure : 1.6 Kg/cm²

Injection pipe : Inner Dia. 2 mm X Outer Dia. 6 mm - Length 600 mm

Test Oil : ISO4113 or SAE Standard Test Oil (SAE J967d) Oil Temp. : 40⁺⁵ °C

Overflow valve opening pressure : Kg/cm²

2. Injection Timing :

Pre-stroke : No. 1 Plunger 1.95 ±0.05mm
 Note : Adjust with control rod position of mm

Injection order : 1 $270 \pm 30^\circ$ 2, 1 $90 \pm 30^\circ$ 1 (interval : $\pm 30^\circ$)

Plungers are numbered from the Drive side.

Tappet clearance : Bolt adjustment type : More than 0.3mm for all cylinders.
 : Shim adjustment type : Manually rotate the camshaft 2~3 times and confirm that it rotates smoothly.

4. Injection Quantity :

Adjusting Point	Rod Position (mm)	Pump Speed (r.p.m)	Injection Q'ty (cc/1000 strokes)	Max. var bet. cyl (%)	Fixed	Remarks
A	9.3	1,250	49.5 ~ 51.5	±3	Lever	Basic
H	(9.3)	1,000	48.0 ~ 50.0	±4	Lever	
B	Approx. 7.3	350	5.0 ~ 7.0	±14	Lever	

5. Timing Advance Specification :

Pump Speed (r.p.m)	Advance Angle (deg.)

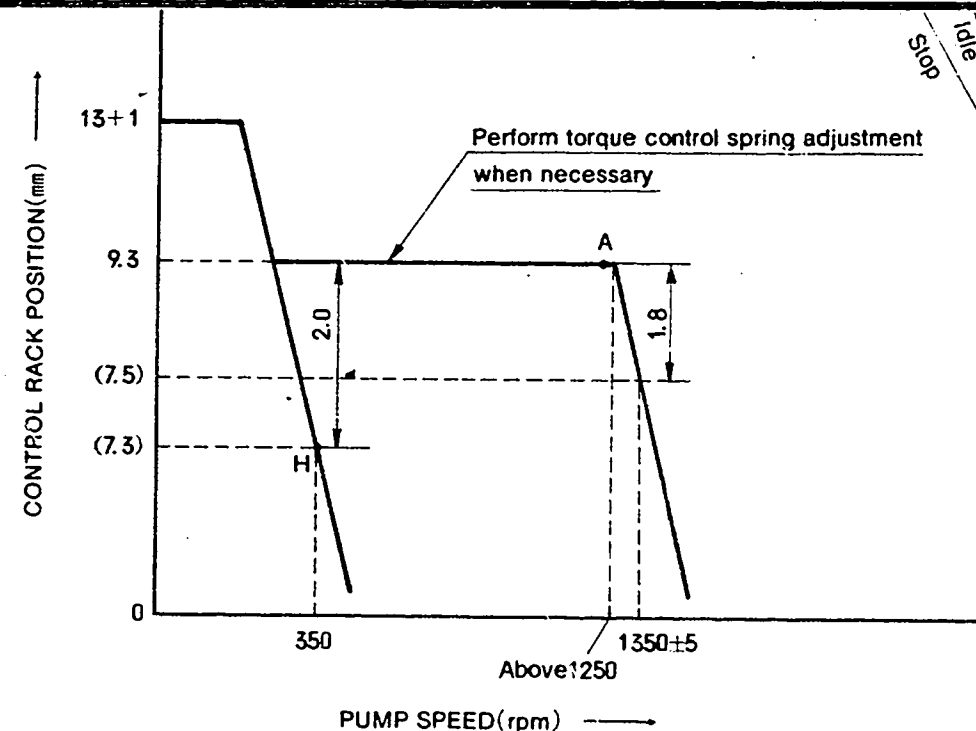

■ Adjustment

Item	Pump Speed (rpm)	Rack position (mm)	Remarks
Full-Load Stopper Bolt Adjustment	1250	9.3	• Adjust using screw ①.
	1250	9.3	• Confirm injection quantity at point A. • Confirm the control lever angle (13°~19°).
Maximum Speed Adjustment	Fix the control lever in the full-speed position.		
Idling Adjustment	Above 1250 1345~1355	9.3 (7.5)	• Adjust using screw ②. • Confirm
	350 (1000)	(7.3) 9.3	• Adjust using idling spring guide. • Confirm injection quantity at point H.
	0	13+1	• Confirm
Stopper Bolt Adjustment	100	(7.3)-1	• Adjust using screw ③.



DIESEL KIKI

DIESEL KIKI CO., LTD.
 Service Department

3-6-7 SHIBUYA, SHIBUYA-KU, TOKYO 150, JAPAN
 Tel (03)400-1551-Fax (03)499-4115

H - 13

104302-6470 3/3

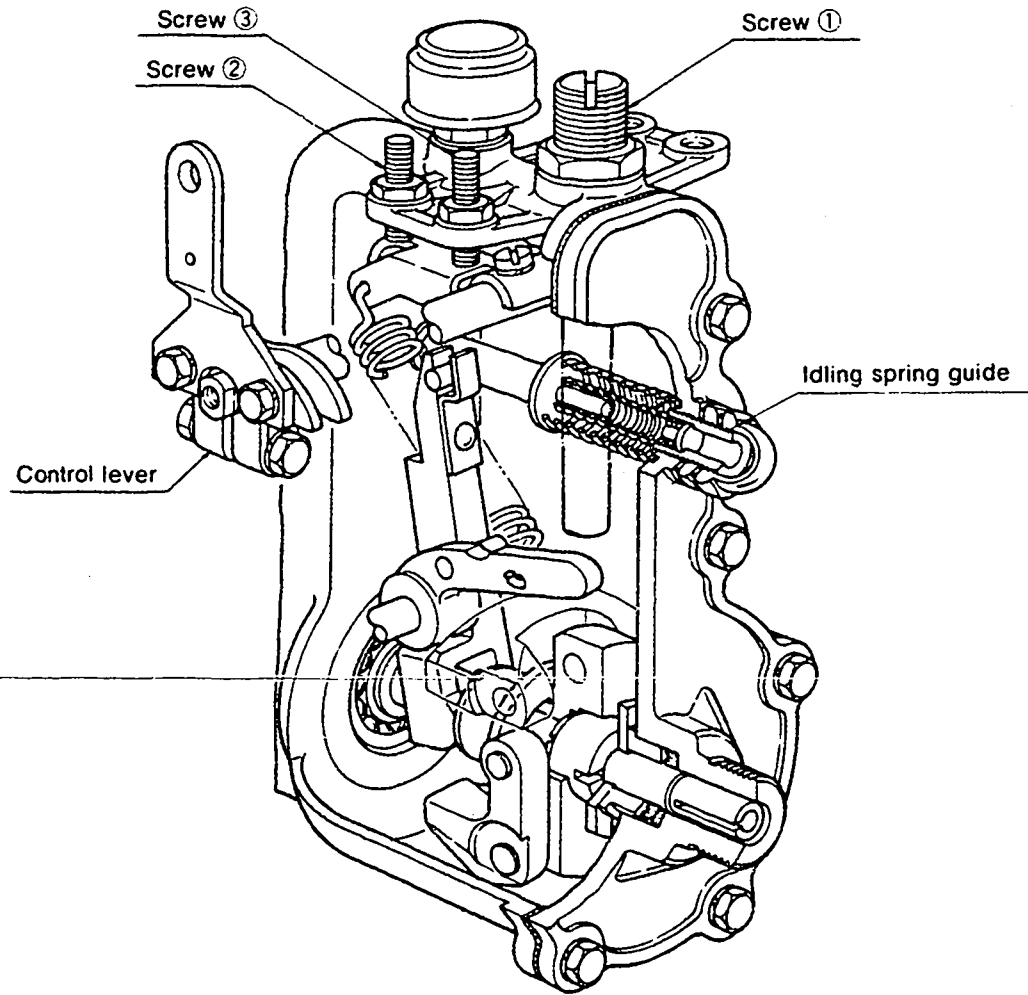

INJ. PUMP CALIBRATION DATA

ENGINE MODEL 6D22T0

BOSCH No. 9 400 610 041
 DKKC No. 106651-2150
 Date: 20. Nov. 1986 2
 Company: MITSUBISHI
 No. ME056398

Injection pump : PE6P 106065-5280
 Governor : EP/RFD-C 105487-1640
 Timing device : EP/SP 105636-1060

1. Test Conditions :

Pump rotation : clockwise viewed from drive side

Nozzle & Nozzle Holder Ass'y : 105780-0000 (BOSCH Type No. DN12SD12)
 Nozzle Holder : 105780-2080 (BOSCH Type No. EF8511/9A)
 Nozzle opening pressure : 175 Kg/cm²
 Transfer pump pressure : 1.6 Kg/cm²

Injection pipe : Inner Dia. 3 mm X Outer Dia. 8 mm - Length 600 mm

Test Oil : ISO4113 or SAE Standard Test Oil (SAE J967d) Oil Temp. : 40^{±5} °C

Overflow valve opening pressure : 1.6 Kg/cm²

2. Injection Timing :

Pre-stroke : No. 1 Plunger 5.1 ± 0.05 mm

Note : Adjust with control rod position of mm

Injection order : 1 ~ 5 ~ 3 ~ 6 ~ 2 ~ 4 (interval : 60° ± 30')

Plungers are numbered from the Governor side.

Tappet clearance : Bolt adjustment type : More than 0.3mm for all cylinders.
 Shim adjustment type : Manually rotate the camshaft 2~3 times and confirm that it rotates smoothly.

4. Injection Quantity :

Adjusting Point	Rod Position (mm)	Pump Speed (r.p.m)	Injection Q'ty (cc/1000 strokes)	Max. var bet. cyl (cc)	Fixed	Remarks
	12.1	700	165.5 ~ 143.5	—	Rack	Basic Each cylinder
H	Approx. 6.3	225	15.9 ~ 21.3	—	Rack	
A	R.(12.1)	700	139.0 ~ 141.0	—	Lever	Basic Boost press. Above 475mmHg
B	R.(12.1)	1,100	qA-5 ≤ qB ≤ qA+3	8	Lever	Boost press. Above 475mmHg
D	11.5	500	117.4 ~ 124.6	—	Lever	Boost press. Above 250mmHg
E	—	100	90.0 ~ 130.0	—	Lever	

5. Timing Advance Specification :

Pump Speed (r.p.m)	Below 950	900	1,050
Advance Angle (deg.)	Start	Below 0.5	Finish 3.0~4.0

3. GOVERNOR ADJUSTMENT

106651-2150 2/4

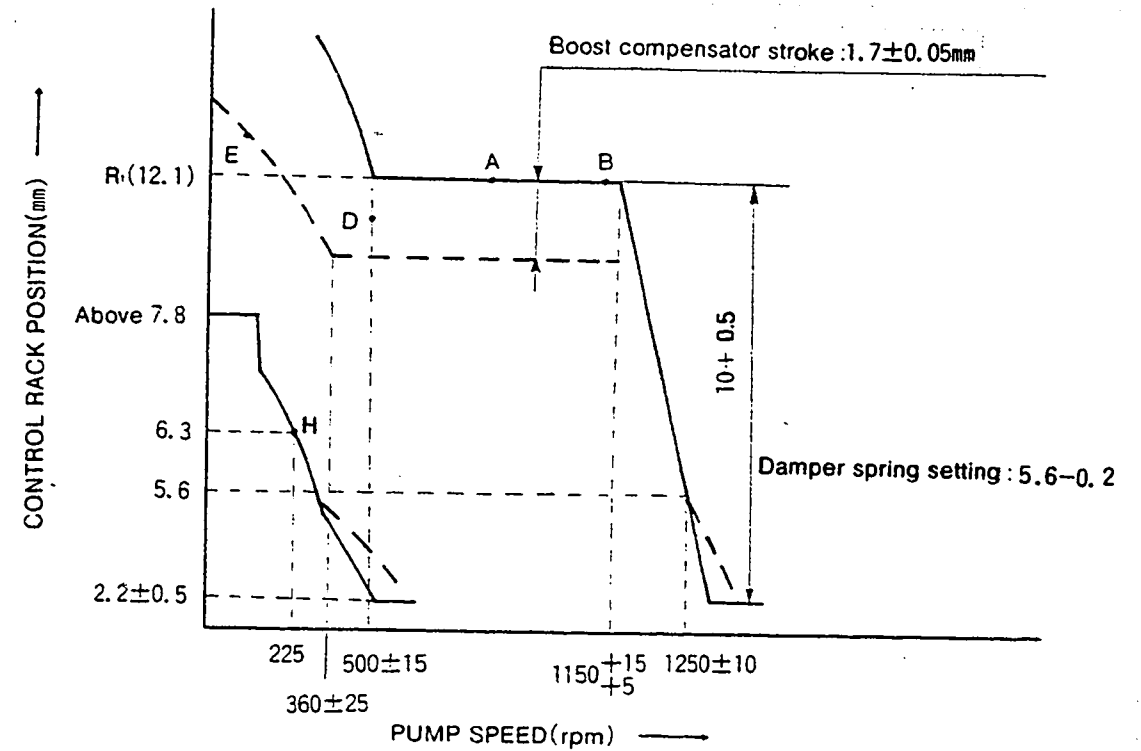

• LOAD CONTROL LEVER ANGLE

• SPEED CONTROL LEVER ANGLE

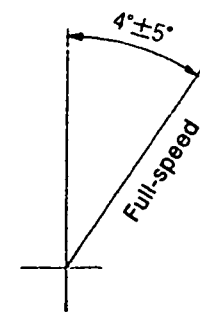
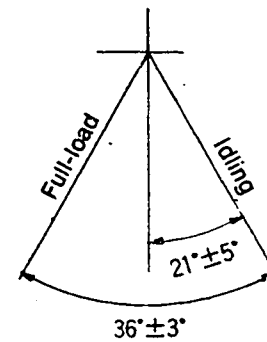

■ Note :

Before adjustment, remove the damper spring, the cover and the idling spring capsule.

■ Adjustment

Item	Pump Speed (rpm)	Rack Position (mm)	Remarks
Flyweight Lift And Full-Load Position	700~800	R ₁ (12.1)	• Speed control lever: temporary setting.
	Approx. 1300	Approx. 2.1	• Adjust using screw ①.
Decrease pump speed to 1150 ± 15 rpm and adjust the high speed lift value (10 ± 0.5) using screw ②.			
Idling Adjustment	500±15	22±0.15	• Adjust using screw ③
	225	6.3	• Adjust using spring capsule ①
	0	Above 7.8	• Confirm
	500±15	2.2±0.5	• Confirm
	—	—	• Confirm the control lever angle is $21^\circ \pm 5^\circ$.
Damper Spring Setting	Maintain the pump speed at 225 rpm and set the control rod at the 6.3 mm position using the control lever. Then, gradually increase the pump speed until the rod position is 5.6-0.2 mm. Tighten the damper spring capsule and fix it in the position where it begins to move the rod from the 5.6-0.1 mm position.		
Maximum Speed Starting Point and Speed Droop Check	Fix the load control lever in the full-load position and fix the speed control lever in the full-speed position.		
	1150 ± 15	R ₁ (12.1)	• Adjust using screw ④
	1250±10	5.6	• Confirm
	—	—	• Confirm the control lever angle (Speed lever angle: $4^\circ \pm 5^\circ$; Load lever angle $36^\circ \pm 3^\circ$).
	Approx. 1300	—	• Confirm that there is no fuel injection.
Smoke Limiter Setting	Fix the load control lever in the full-load position.		
	—	—	• Adjust using smoke limiter.
	—	—	• Confirm injection quantity at point E.

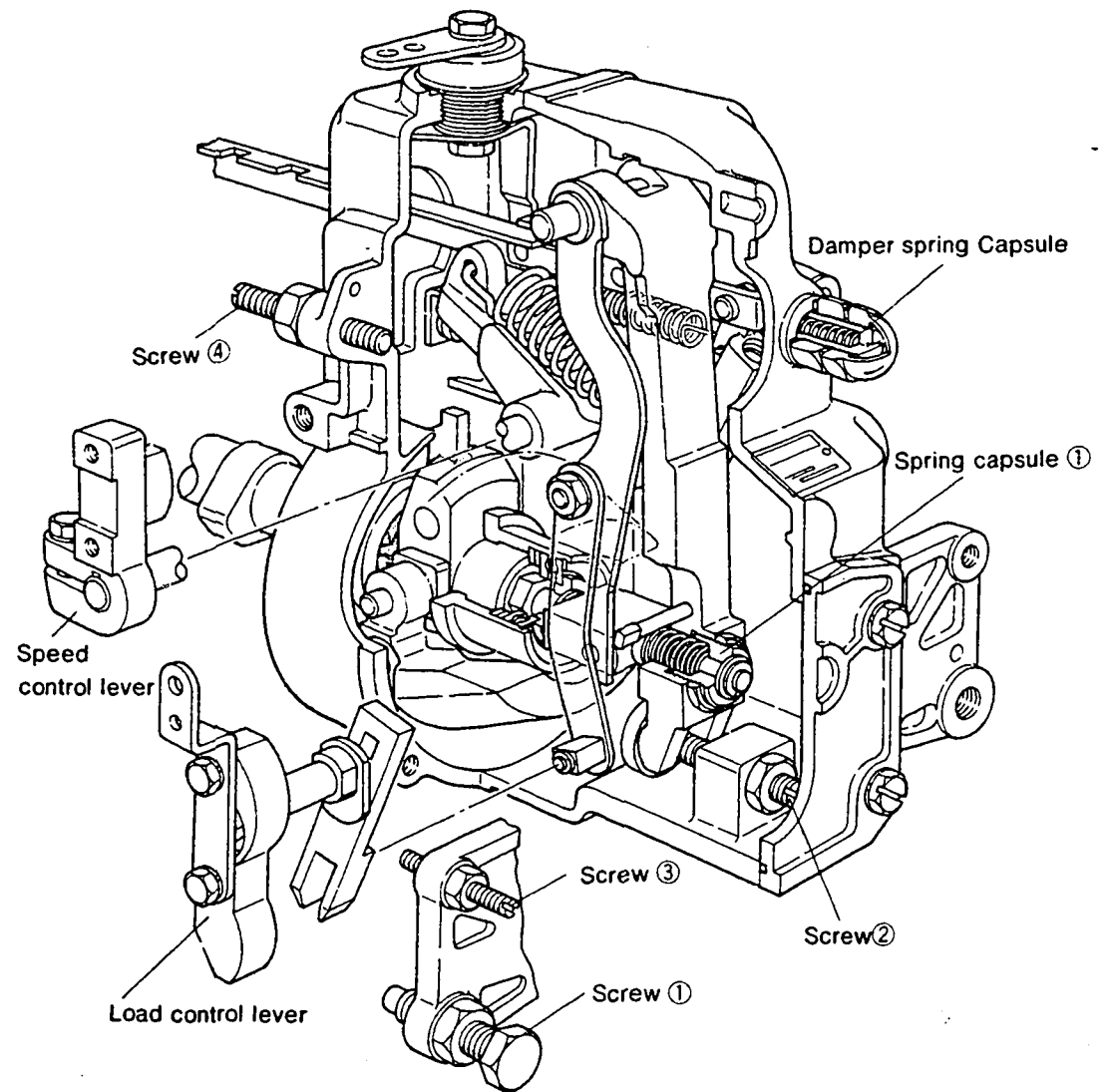

INJ. PUMP CALIBRATION DATA

BOSCH No.9 400 610 044
 DKKC No. 106671-3793
 Date : 20.Nov.1986
 Company : HINO
 No. 22020 18643

ENGINE MODEL EP100-T

Injection pump : PE6P 106067-7421 Governor : EP/RSV 105407-2421 Timing device : EP/RSV 105636-1170

1. Test Conditions :

Pump rotation : clockwiseviewed from drive side

Nozzle & Nozzle Holder Ass'y : 105780-0000 (BOSCH Type No.DN12SD12) Nozzle Holder : 105780-2080 (BOSCH Type No.EF8511/9A)

Nozzle opening pressure : 175 Kg/cm² Transfer pump pressure : 1.6 Kg/cm²

Injection pipe : Inner Dia. 3 mm X Outer Dia. 8 mm - Length 600 mm

Test Oil : ISO4113 or SAE Standard Test Oil (SAE J967d) Oil Temp. : 40⁺⁵ °C

Overflow valve opening pressure : Kg/cm²

2. Injection Timing :

Pre-stroke : No. 1 Plunger 4.5 -0.1mm
 Note : Adjust with control rod position of mm

Injection order : 1 ~ 4 ~ 2 ~ 6 ~ 3 ~ 5 (interval : 60° ± 30°)

Plungers are numbered from the Drive side.

Tappet clearance : Bolt adjustment type ; More than 0.3mm for all cylinders.
 : Shim adjustment type ; Manually rotate the camshaft 2~3 times and confirm that it rotates smoothly.

4. Injection Quantity :

Adjusting Point	Rod Position (mm)	Pump Speed (r.p.m)	Injection Q'ty (cc/1000 strokes)	Max. var bet. cyl (%)	Fixed	Remarks
A	7.9	800	109.0 ~ 113.0	±2	Rack	Basic
H	Approx. 5.1	360	7.0 ~ 13.0	±15	Rack	
A	7.9	800	109.0 ~ 113.0	-	Lever	Basic
C	-	100	143.0 ~ 153.0	-	Lever	Control rack limit

5. Timing Advance Specification :

Pump Speed (r.p.m)	Below 975	925	1,000			
Advance Angle (deg.)	Start	Below 0.3	Finish (2.5)			

3. GOVERNOR ADJUSTMENT

106671-3793 2/4

Recommended speed droop adjustment screw position : (9)
 (Notches from fully tightened position)

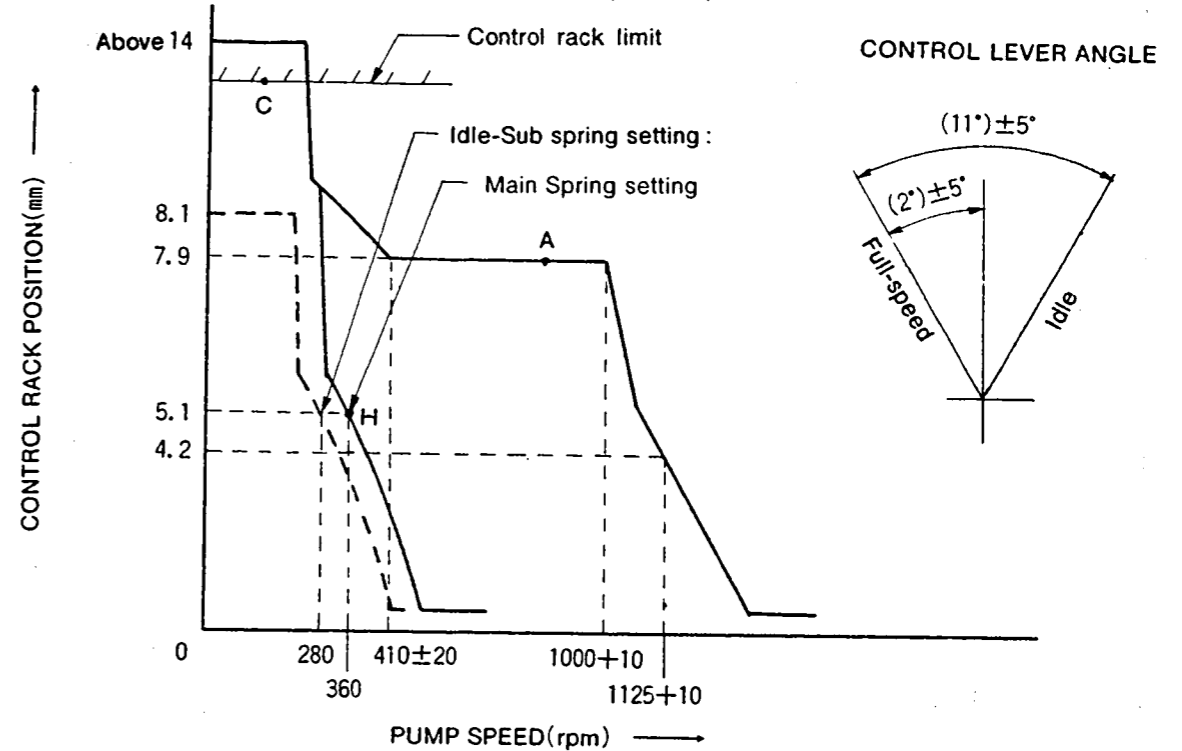

Note

- Before adjustment, remove the idling sub spring and the torque control spring.
- Move the control lever fully in the stop direction, and set the minimum-speed stopper bolt so that the control rack position is 0.5~1.0 mm.

Adjustment

Item	Pump Speed (rpm)	Rack Position (mm)	Remarks
Full-load Adjustment (Temporary)	1000±10	9.9	• Adjust using screw ①
	800	7.9	• Adjust using screw ②
Torque Control Spring Adjustment	---	---	• Adjust using spring capsule ①
	---	---	• Confirm
	---	---	• Confirm
	---	---	• Confirm the torque control stroke is --- mm.

106671-3793 3/4

106671-3793 4/4

Item	Pump Speed (rpm)	Rack Position (mm)	Remarks
Idling Adjustment	360	5.1	• Fix the control lever
	280	5.1	• Adjust using spring capsule ②
	0	8.1	• Confirm
Maximum-speed Adjustment	1000+10	7.9	• Adjust using screw ①
	1125±25	4.2	• Confirm speed droop
	—	—	• Confirm
Full-load Adjustment (Install the cover on governor cover)	200	7.9	• Adjust using screw ②
Control Lever Angle Measurement	<ul style="list-style-type: none"> • Measure the control lever angle at the "idling" and "full" positions. • When the control lever is depressed toward the "full" position, replace the shifter's shim with a thicker one. • When the control lever is depressed toward the "idling" position, replace the shifter's shim with a thinner one. 		
Rack Limiter Adjustment	100	—	• Adjust using screw

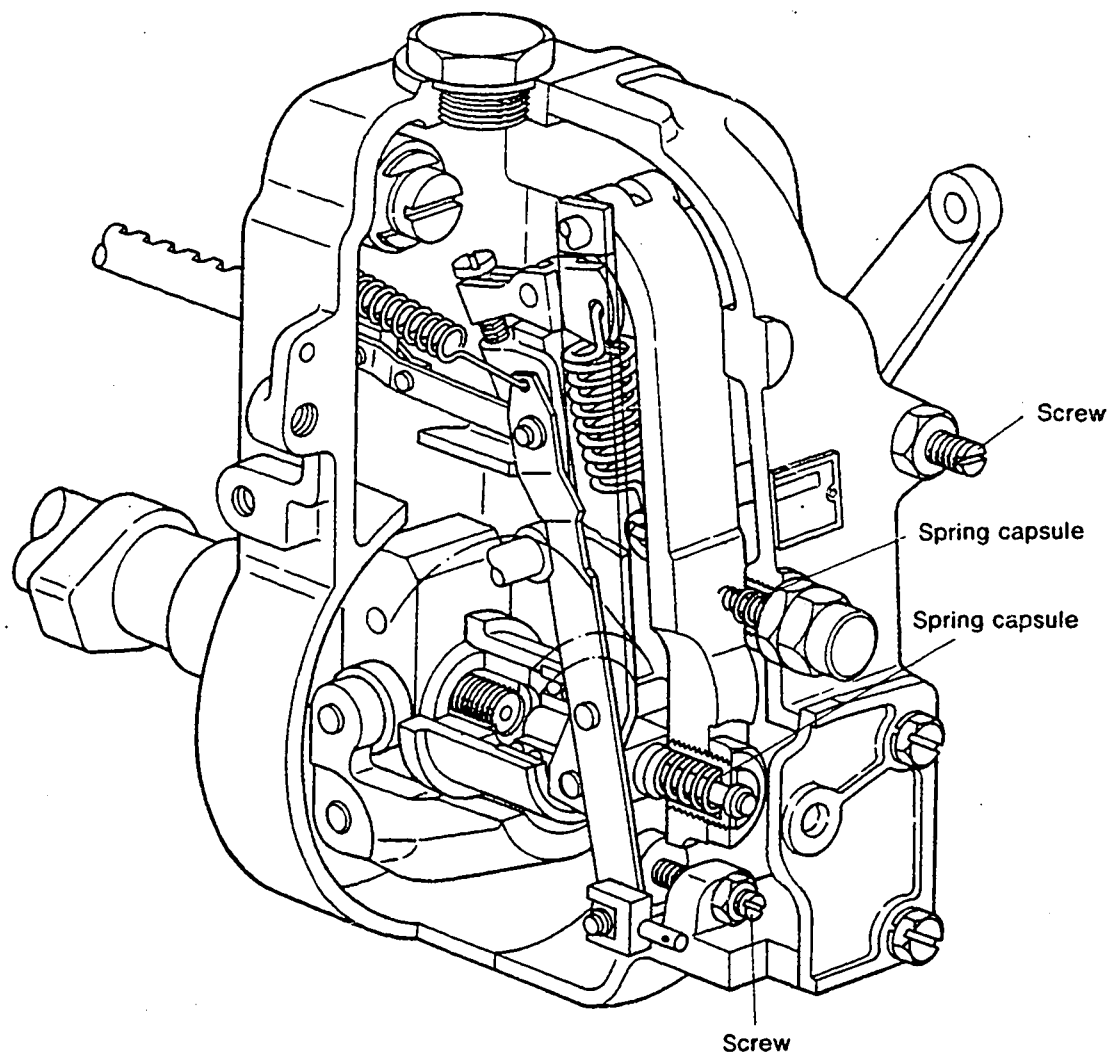

INJ. PUMP CALIBRATION DATA

ENGINE MODEL 8DC81

BOSCH No. 9 400 610 042
 DKKC No. 106871-2100
 Date: 20 Nov. 1986 6
 Company: MITSUBISHI
 No. ME066073

Injection pump : PE8P 106087-5182 Governor : EP/RFD-D 105487-0810 Timing device : EP/SP 105636-0460

1. Test Conditions :

Pump rotation : clockwise viewed from drive side

Nozzle & Nozzle Holder Ass'y : 105780-0000 (BOSCH Type No. DN12SD12) Nozzle Holder : 105780-2080 (BOSCH Type No. EF8511/9A)

Nozzle opening pressure : 175 Kg/cm² Transfer pump pressure : 1.6 Kg/cm²

Injection pipe :
 Inner Dia. 3 mm X Outer Dia. 8 mm - Length 600 mm

Test Oil : ISO4113 or SAE Standard Test Oil (SAE J967d) Oil Temp. : 40^{±5} °C

Overflow valve opening pressure : 1.6 Kg/cm²

2. Injection Timing :

Pre-stroke : No. 1 Plunger 4.8 ±0.05mm

Note : Adjust with control rod position of _____ mm

Injection order : 1 ~ 2 ~ 7 ~ 3 ~ 4 ~ 5 ~ 6 ~ 8 (interval : 45 ° ± 30°)

Plungers are numbered from the Governor side.

Tappet clearance : Bolt adjustment type : More than 0.3mm for all cylinders.
 : Shim adjustment type : Manually rotate the camshaft 2~3 times and confirm that it rotates smoothly.

4. Injection Quantity :

Adjusting Point	Rod Position (mm)	Pump Speed (r.p.m)	Injection Q'ty (cc/1000 strokes)	Max. var bet. cyl (cc)	Fixed	Remarks
	9.0	700	82.6 ~ 87.6	—	Rack	Basic Each cylinder
H	Approx. 6.7	200	15.7 ~ 21.3	—	Rack	
A	R: (Approx. 9.0)	700	84.0 ~ 86.0	—	Lever	Basic
B	R: (Approx. 9.0)	1,000	qA+8.1 ≤ qB ≤ qA+15.9	7.8	Lever	
E	—	100	115.2 ~ 155.2	—	Lever	After setting excessive fuel for starting
D	R+0.2	500		—	Lever	

5. Timing Advance Specification :

Pump Speed (r.p.m)	550~650	700	850	1,000	1,150
Advance Angle (deg.)	Start	0.2~1.2	1.5~2.5	3.1~4.1	Finish 5.0~6.0

3. GOVERNOR ADJUSTMENT

106871-2100 2/4

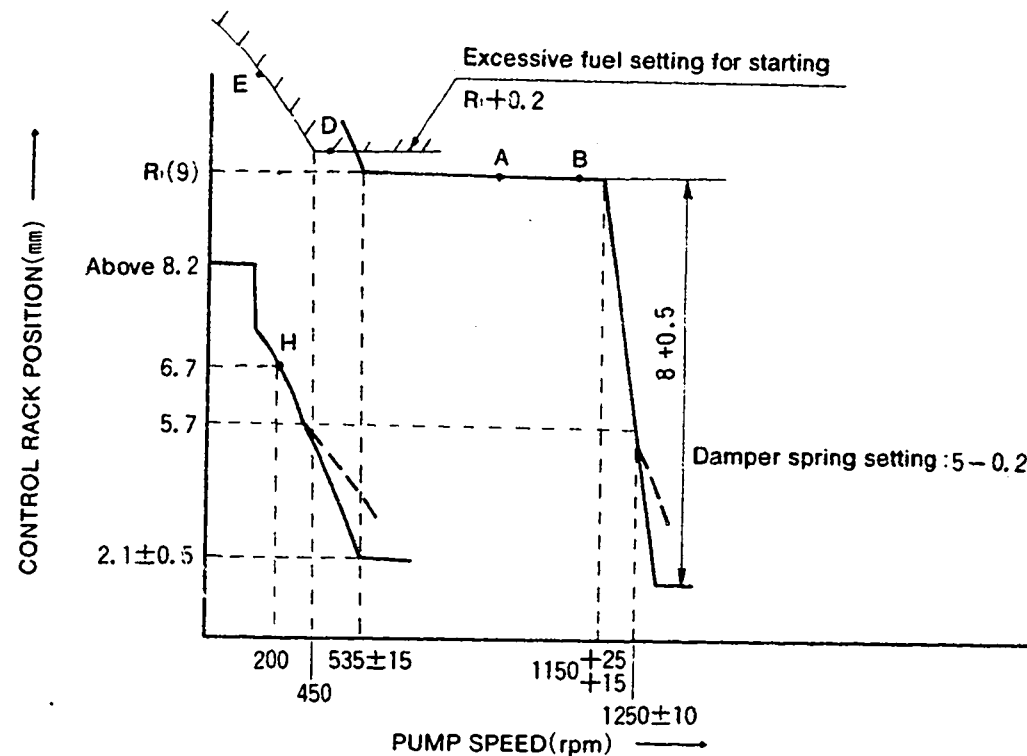

• LOAD CONTROL LEVER ANGLE

• SPEED CONTROL LEVER ANGLE

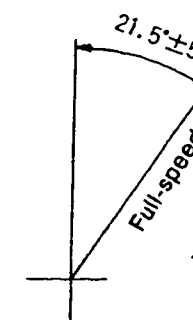
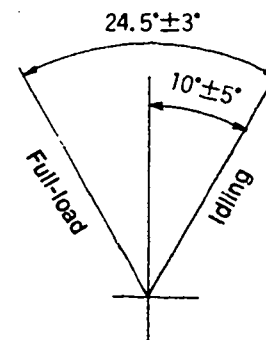

■ Note :

Before adjustment, remove the damper spring, the cover and the idling spring capsule.

■ Adjustment

Item	Pump Speed (rpm)	Rack Position (mm)	Remarks
Flyweight Lift And Full-Load Position	700~800	R ₁ (9)	• Speed control lever: temporary setting.
	Approx. 1300	Approx. 1.0	• Adjust using screw ①.
	Decrease pump speed to $1150 \pm \frac{25}{10}$ rpm and adjust the high speed lift value (8 ± 0.5) using screw ②.		
Idling Adjustment	535 ± 15	2.1 ± 0.5	• Adjust using screw ③
	200	6.7	• Adjust using spring capsule ①
	0	Above 8.2	• Confirm
	535 ± 15	2.1 ± 0.5	• Confirm
	• Confirm the control lever angle is $10 \pm 5^\circ$.		
Damper Spring Setting	Maintain the pump speed at 200 rpm and set the control rod at the 6.7 mm position using the control lever. Then, gradually increase the pump speed until the rod position is 5-0.2 mm. Tighten the damper spring capsule and fix it in the position where it begins to move the rod from the 5-0.1 mm position.		
Maximum Speed Starting Point and Speed Droop Check	Fix the load control lever in the full-load position and fix the speed control lever in the full-speed position.		
	$1150 \pm \frac{25}{10}$ 1250 ± 10 —	R ₁ (9) 5.7 —	• Adjust using screw ④ • Confirm • Confirm the control lever angle (Speed lever angle: $21.5 \pm 5^\circ$; Load lever angle $24.5 \pm 3^\circ$).
	Approx. 1300	—	• Confirm that there is no fuel injection.
Smoke Limiter Setting	Fix the load control lever in the full-load position.		
	500 100	R ₁ + 0.2 —	• Adjust using smoke limiter. • Confirm injection quantity at point E.

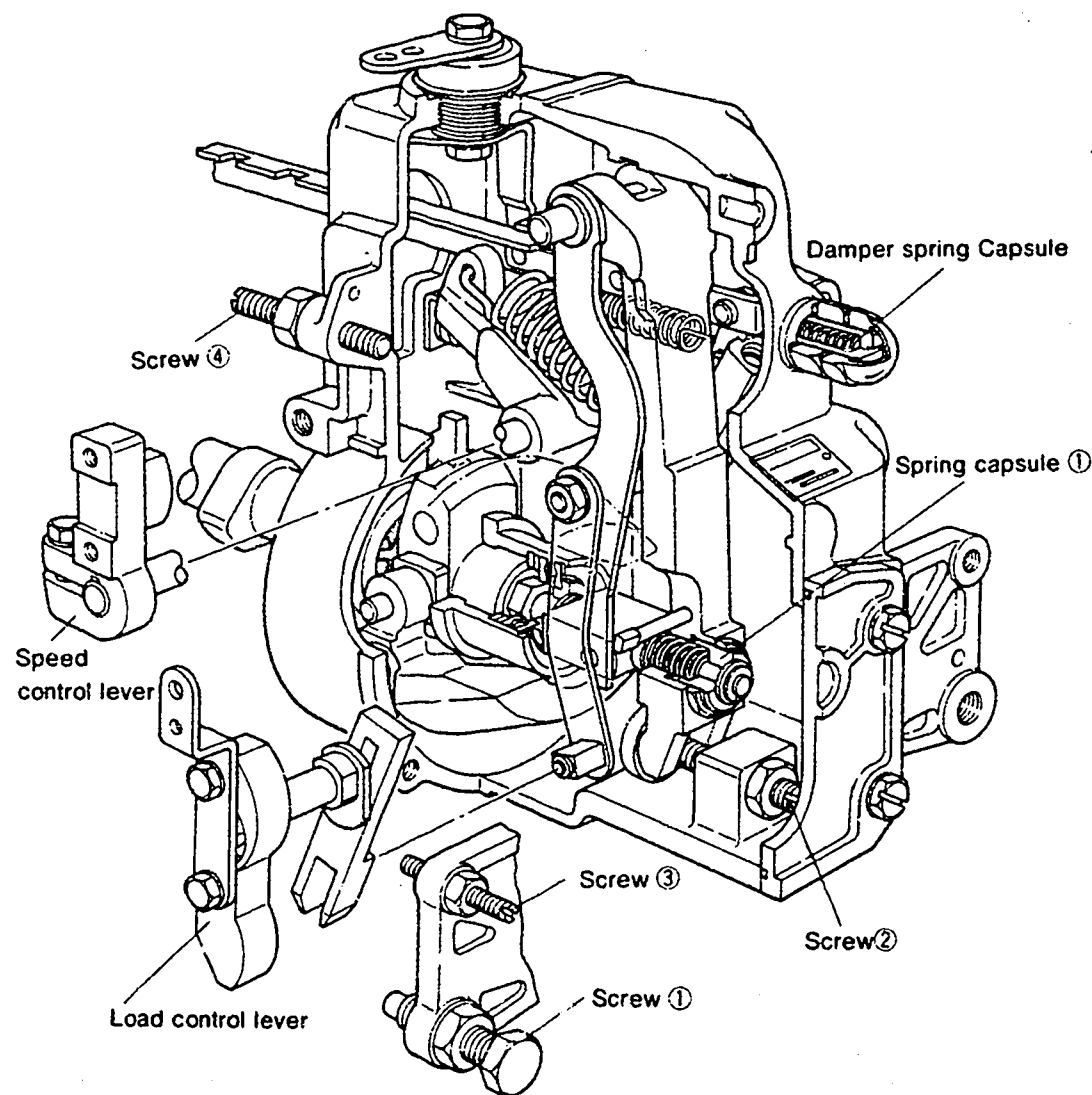

INJ. PUMP CALIBRATION DATA

ENGINE MODEL 8DC8

BOSCH No. 9 400 610 043
 DKKC No. 106871-2590
 Date: 20.Nov.1986 ③
 Company: MITSUBISHI
 No. ME066612

Injection pump: PE8P 106087-5510 Governor: EP/RFD-D 105487-1580 Timing device: EP/SP 105636-0770

1. Test Conditions :

Pump rotation : clockwise viewed from drive side

Nozzle & Nozzle Holder Ass'y : 105780-0000 (BOSCH Type No. DN12SD12) Nozzle Holder : 105780-2080 (BOSCH Type No. EF8511/9A)

Nozzle opening pressure : 175 Kg/cm² Transfer pump pressure : 1.6 Kg/cm²

Injection pipe : Inner Dia. 3 mm X Outer Dia. 8 mm - Length 600 mm

Test Oil : ISO4113 or SAE Standard Test Oil (SAE J967d) Oil Temp. : 40^{±5} °C

Overflow valve opening pressure : 1.6 Kg/cm²

2. Injection Timing :

Pre-stroke : No. 1 Plunger 4.8 ± 0.05 mm
 Note : Adjust with control rod position of _____ mm

Injection order : 1 ~ 2 ~ 7 ~ 3 ~ 4 ~ 5 ~ 6 ~ 8 (interval : 45 ° ± 30')
 Plungers are numbered from the Governor side.

Tappet clearance : Bolt adjustment type : More than 0.3mm for all cylinders.
 Shim adjustment type : Manually rotate the camshaft 2~3 times and confirm that it rotates smoothly.

4. Injection Quantity :

Adjusting Point	Rod Position (mm)	Pump Speed (r.p.m)	Injection Q'ty (cc/1000 strokes)	Max. var bet. cyl (cc)	Fixed	Remarks
A	8.8	700	94.1 ~ 99.9	—	Rack	Basic Each cylinder
H	Approx. 6.1	225	17.0 ~ 23.0	—	Rack	
A	R.(8.8)	700	96.0 ~ 98.0	—	Lever	Basic
B	R.(8.8)	1,100	qA+4.5 ≤ qB ≤ qA+12.9	8.4	Lever	
C	9.4 ± 0.1	330	—	—	Lever	
D	—	100	110.0 ~ 150.0	—	Lever	After setting excessive fuel for starting

5. Timing Advance Specification :

Pump Speed (r.p.m)	950	1,050	1,150
Advance Angle (deg.)	Start 0.5	2.2~3.2	5.5~6.5

3. GOVERNOR ADJUSTMENT

106871-2590 2/4

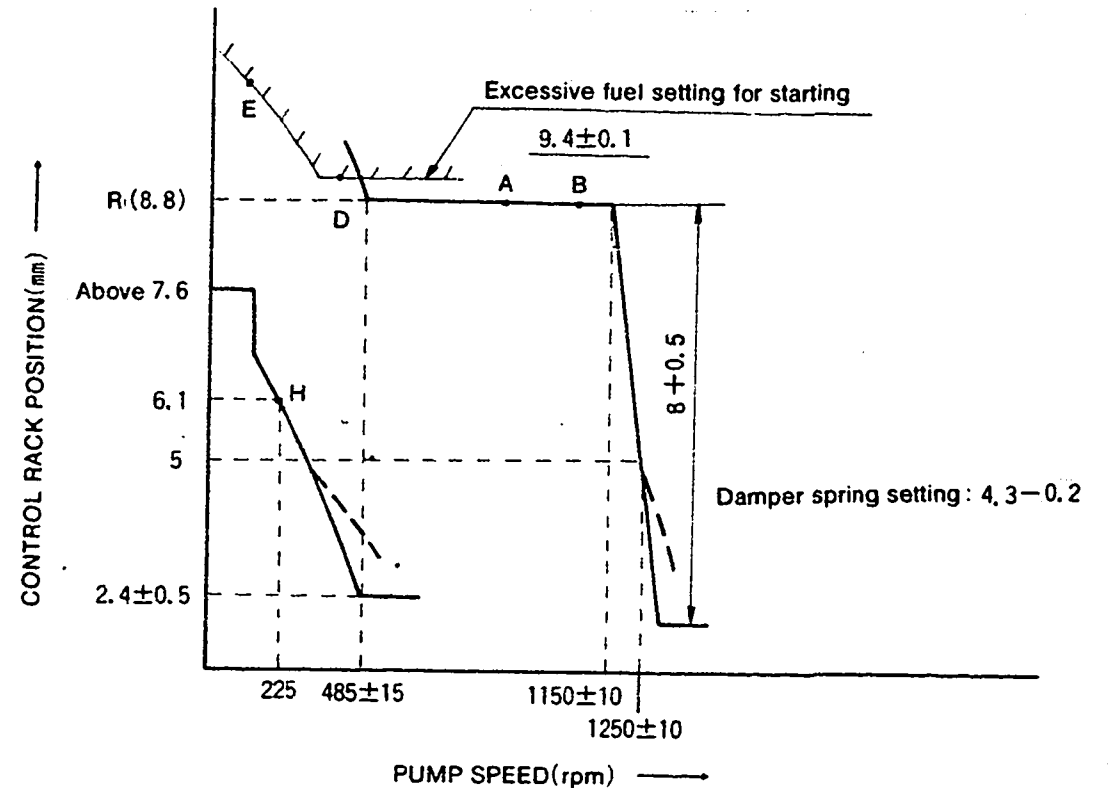

• LOAD CONTROL LEVER ANGLE

• SPEED CONTROL LEVER ANGLE

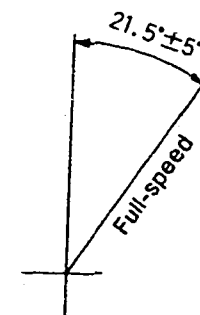
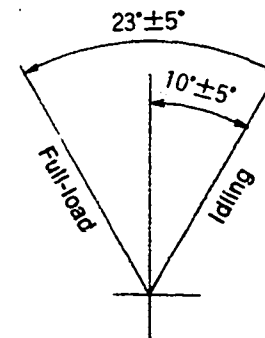

■ Note :

Before adjustment, remove the damper spring, the cover and the idling spring capsule.

■ Adjustment

Item	Pump Speed (rpm)	Rack Position (mm)	Remarks
Flyweight Lift And Full-Load Position	700~800	R ₁ (8.8)	• Speed control lever: temporary setting.
	Approx. 1300	Approx. 0.8	• Adjust using screw ①.
Decrease pump speed to 1150+10 rpm and adjust the high speed lift value (8+0.5) using screw ②.			
Idling Adjustment	485±15	2.4±0.5	• Adjust using screw ③
	225	6.1	• Adjust using spring capsule ①
	0	Above 7.6	• Confirm
	485+15	2.4±0.5	• Confirm
	—	—	• Confirm the control lever angle is 10°±5°.
Damper Spring Setting	Maintain the pump speed at 225 rpm and set the control rod at the 8 mm position using the control lever. Then, gradually increase the pump speed until the rod position is 4.3-0.2 mm. Tighten the damper spring capsule and fix it in the position where it begins to move the rod from the 4.3-0.1 mm position.		
Maximum Speed Starting Point and Speed Droop Check	Fix the load control lever in the full-load position and fix the speed control lever in the full-speed position.		
	1150±15	R ₁ (8.8)	• Adjust using screw ④
	1250±10	5	• Confirm
	—	—	• Confirm the control lever angle (Speed lever angle: 21.5 ± 5°; Load lever angle 23.5 ± 3°).
	Approx. 1300	—	• Confirm that there is no fuel injection.
Smoke Limiter Setting	Fix the load control lever in the full-load position.		
	330	9.4±0.1	• Adjust using smoke limiter.
	100	—	• Confirm injection quantity at point E.

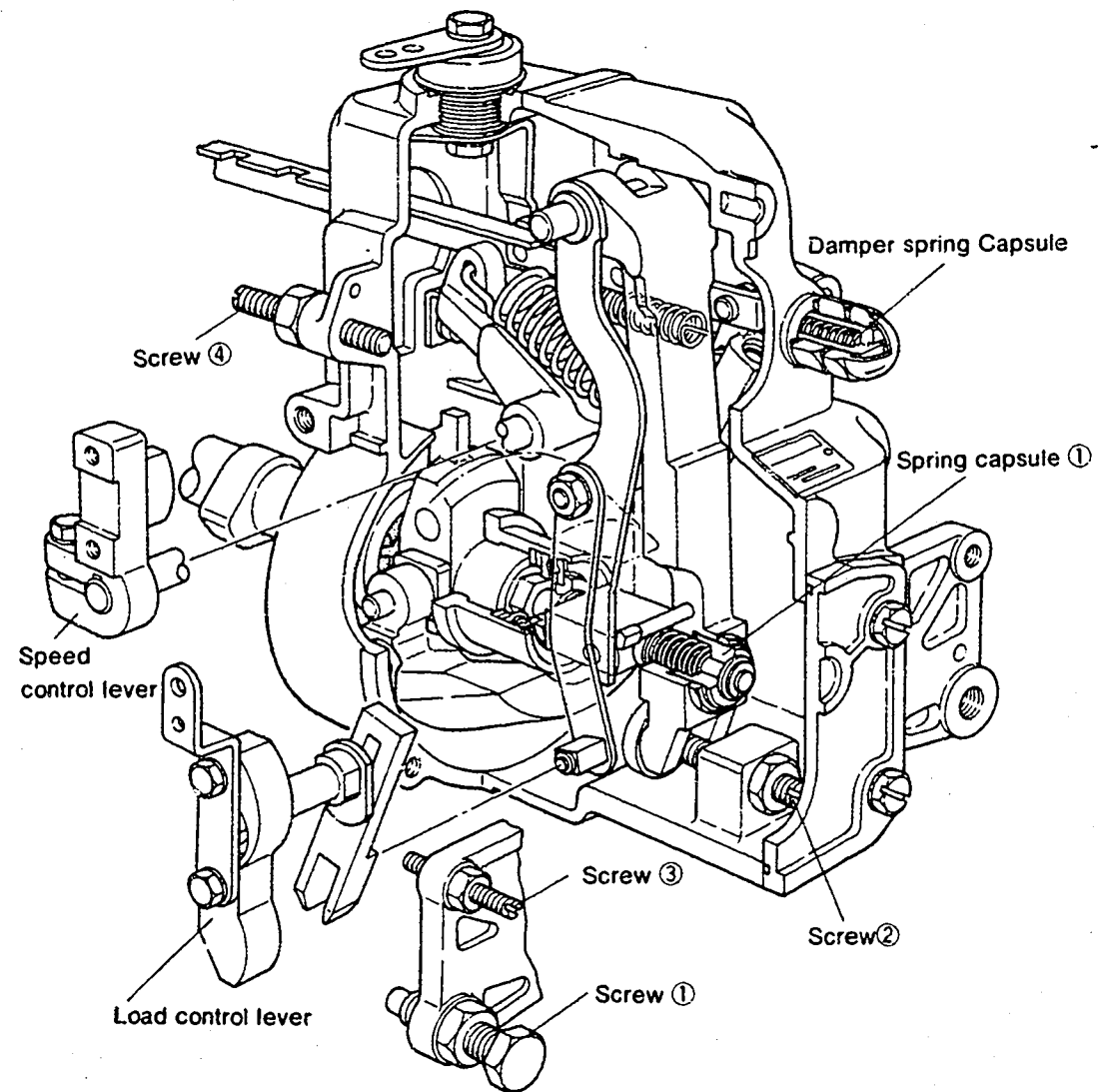

Table of Contents (BOSCH No. — DKKC No.)

Table of Contents (DKKC No. — BOSCH No.)

BOSCH No.	DKKC No.	Location	BOSCH No.	DKKC No.	Location
9 400 610 000	101431-0580	WP-213 B-5 ~B-6	9 400 610 033	101433-9401	WP-213 C-9 ~C-10
9 400 610 001	101431-9770	WP-213 B-13~B-14	9 400 610 034	101433-9421	WP-213 C-11~C-12
9 400 610 002	101431-9900	WP-213 C-1 ~C-2	9 400 610 035	101441-9040	WP-213 C-13~C-14
9 400 610 003	101631-9660	WP-213 F-11~F-12	9 400 610 036	101441-9200	WP-213 D-3 ~D-4
9 400 610 004	101641-9122	WP-213 G-4 ~G-6	9 400 610 037	101451-9400	WP-213 D-5 ~D-6
9 400 610 005	101641-9132	WP-213 G-7 ~G-9	9 400 610 038	101631-9661	WP-213 F-13 ~F-14
9 400 610 006	101641-9151	WP-213 G-10~G-12	9 400 610 039	101603-1341	WP-213 F-7 ~F-8
9 400 610 007	101433-9390	WP-213 C-7 ~C-8	9 400 610 040	101603-1830	WP-213 F-9 ~F-10
9 400 610 008	101401-0270	WP-213 B-1 ~B-2	9 400 610 041	106651-2150	WP-213 H-14~H-15
9 400 610 009	101441-9121	WP-213 C-15~C-16	9 400 610 042	106871-2100	WP-213 I-3 ~I-4
9 400 610 010	101441-9131	WP-213 D-1 ~D-2	9 400 610 043	106871-2590	WP-213 I-5 ~I-6
9 400 610 011	101461-0410	WP-213 D-7 ~D-8	9 400 610 044	106671-3793	WP-213 I-1 ~I-2
9 400 610 012	101461-0471	WP-213 D-9 ~D-10	9 400 610 046	101631-9772	WP-213 F-15~F-16
9 400 610 013	101471-0290	WP-213 D-11~D-12	9 400 610 047	101631-9841	WP-213 G-1 ~G-3
9 400 610 014	101491-0032	WP-213 D-13~D-14	9 400 610 048	101601-1521	WP-213 F-1 ~F-2
9 400 610 015	101491-0262	WP-213 E-1 ~E-2	9 400 610 049	101401-0590	WP-213 B-3 ~B-4
9 400 610 016	101491-0272	WP-213 E-3 ~E-5	9 400 610 051	101491-9084	WP-213 E-8 ~E-9
9 400 610 017	101491-9083	WP-213 E-6 ~E-7	9 400 610 052	101491-9094	WP-213 E-12~E-13
9 400 610 018	101491-9093	WP-213 E-10~E-11	9 410 617 000	104205-2010	WP-213 H-5
9 400 610 019	101601-8651	WP-213 F-3 ~F-4	9 410 617 001	104205-3010	WP-213 H-6
9 400 610 020	101601-8671	WP-213 F-5 ~F-6	9 410 617 002	104293-2020	WP-213 H-7
9 400 610 021	101491-0161	WP-213 D-15~D-16	9 410 617 003	104293-3000	WP-213 H-9
9 400 610 022	101685-0600	WP-213 H-1 ~H-2	9 410 617 004	104293-3010	WP-213 H-10
9 400 610 023	101601-1480	WP-213 E-14~E-15	9 410 617 005	104293-4000	WP-213 H-11
9 400 610 024	104302-6470	WP-213 H-12~H-13	9 410 617 006	104293-2030	WP-213 H-8
9 400 610 025	101891-6620	WP-213 H-3 ~H-4			
9 400 610 026	101641-9210	WP-213 G-13~G-15			
9 400 610 027	101431-9070	WP-213 B-7 ~B-8			
9 400 610 028	101431-9550	WP-213 B-9 ~B-10			
9 400 610 029	101431-9580	WP-213 B-11~B-12			
9 400 610 030	101431-9850	WP-213 B-15~B-16			
9 400 610 031	101433-9230	WP-213 C-3 ~C-4			
9 400 610 032	101433-9260	WP-213 C-5 ~C-6			

DKKC No.	BOSCH No.	Location	DKKC No.	BOSCH No.	Location
101401-0270	9 400 610 008	WP-213 B-1 ~B-2	101601-8671	9 400 610 020	WP-213 F-5 ~F-6
101401-0590	9 400 610 049	WP-213 B-3 ~B-4	101603-1341	9 400 610 039	WP-213 F-7 ~F-8
101431-0580	9 400 610 000	WP-213 B-5 ~B-6	101603-1830	9 400 610 040	WP-213 F-9 ~F-10
101431-9070	9 400 610 027	WP-213 B-7 ~B-8	101631-9660	9 400 610 003	WP-213 F-11~F-12
101431-9560	9 400 610 028	WP-213 B-9 ~B-10	101631-9661	9 400 610 038	WP-213 F-13 ~F-14
101431-9580	9 400 610 029	WP-213 B-11~B-12	101631-9772	9 400 610 046	WP-213 F-15~F-16
101431-9770	9 400 610 001	WP-213 B-13~B-14	101631-9841	9 400 610 047	WP-213 G-1 ~G-3
101431-9850	9 400 610 030	WP-213 B-15~B-16	101641-9122	9 400 610 004	WP-213 G-4 ~G-6
101431-9900	9 400 610 002	WP-213 C-1 ~C-2	101641-9132	9 400 610 005	WP-213 G-7 ~G-9
101433-9230	9 400 610 031	WP-213 C-3 ~C-4	101641-9151	9 400 610 006	WP-213 G-10~G-12
101433-9260	9 400 610 032	WP-213 C-5 ~C-6	101641-9210	9 400 610 026	WP-213 G-13~G-15
101433-9390	9 400 610 007	WP-213 C-7 ~C-8	101685-0600	9 400 610 022	WP-213 H-1 ~H-2
101433-9401	9 400 610 033	WP-213 C-9 ~C-10	101891-6620	9 400 610 025	WP-213 H-3 ~H-4
101433-9421	9 400 610 034	WP-213 C-11~C-12	104205-2010	9 410 617 000	WP-213 H-5
101441-9040	9 400 610 035	WP-213 C-13~C-14	104205-3010	9 410 617 001	WP-213 H-6
101441-9121	9 400 610 009	WP-213 C-15~C-16	104293-2020	9 410 617 002	WP-213 H-7
101441-9131	9 400 610 010	WP-213 D-1 ~D-2	104293-2030	9 410 617 006	WP-213 H-8
101441-9200	9 400 610 036	WP-213 D-3 ~D-4	104293-3000	9 410 617 003	WP-213 H-9
101451-9400	9 400 610 037	WP-213 D-5 ~D-6	104293-3010	9 410 617 004	WP-213 H-10
101461-0410	9 400 610 011	WP-213 D-7 ~D-8	104293-4000	9 410 617 005	WP-213 H-11
101461-0471	9 400 610 012	WP-213 D-9 ~D-10	104302-6470	9 400 610 024	WP-213 H-12~H-13
101471-0290	9 400 610 013	WP-213 D-11~D-12	106651-2150	9 400 610 041	WP-213 H-14~H-15
101491-0032	9 400 610 014	WP-213 D-13~D-14	106671-3793	9 400 610 044	WP-213 I-1 ~I-2
101491-0161	9 400 610 021	WP-213 D-15~D-16	106871-2100	9 400 610 042	WP-213 I-3 ~I-4
101491-0262	9 400 610 015	WP-213 E-1 ~E-2	106871-2590	9 400 610 043	WP-213 I-5 ~I-6
101491-0272	9 400 610 016	WP-213 E-3 ~E-5			
101491-9083	9 400 610 017	WP-213 E-6 ~E-7			
101491-9084	9 400 610 051	WP-213 E-8 ~E-9			
101491-9093	9 400 610 018	WP-213 E-10~E-11			
101491-9094	9 400 610 052	WP-213 E-12~E-13			
101601-1480	9 400 610 023	WP-213 E-14~E-15			
101601-1521	9 400 610 048	WP-213 F-1 ~F-2			
101601-8651	9 400 610 019	WP-213 F-3 ~F-4			